

# Petroleum, Petrochemical, and Natural Gas Industries—Air-cooled Heat Exchangers

API STANDARD 661  
SEVENTH EDITION, JULY 2013

REAFFIRMED, JUNE 2018



AMERICAN PETROLEUM INSTITUTE

## Special Notes

API publications necessarily address problems of a general nature. With respect to particular circumstances, local, state, and federal laws and regulations should be reviewed.

Neither API nor any of API's employees, subcontractors, consultants, committees, or other assignees make any warranty or representation, either express or implied, with respect to the accuracy, completeness, or usefulness of the information contained herein, or assume any liability or responsibility for any use, or the results of such use, of any information or process disclosed in this publication. Neither API nor any of API's employees, subcontractors, consultants, or other assignees represent that use of this publication would not infringe upon privately owned rights.

Users of this standard should not rely exclusively on the information contained in this document. Sound business, scientific, engineering, and safety judgment should be used in employing the information contained herein.

Work sites and equipment operations may differ. Users are solely responsible for assessing their specific equipment and premises in determining the appropriateness of applying the standard. At all times users should employ sound business, scientific, engineering, and judgment safety when using this standard.

API publications may be used by anyone desiring to do so. Every effort has been made by the Institute to assure the accuracy and reliability of the data contained in them; however, the Institute makes no representation, warranty, or guarantee in connection with this publication and hereby expressly disclaims any liability or responsibility for loss or damage resulting from its use or for the violation of any authorities having jurisdiction with which this publication may conflict.

API publications are published to facilitate the broad availability of proven, sound engineering and operating practices. These publications are not intended to obviate the need for applying sound engineering judgment regarding when and where these publications should be utilized. The formulation and publication of API publications is not intended in any way to inhibit anyone from using any other practices.

Any manufacturer marking equipment or materials in conformance with the marking requirements of an API standard is solely responsible for complying with all the applicable requirements of that standard. API does not represent, warrant, or guarantee that such products do in fact conform to the applicable API standard.

All rights reserved. No part of this work may be reproduced, translated, stored in a retrieval system, or transmitted by any means, electronic, mechanical, photocopying, recording, or otherwise, without prior written permission from the publisher. Contact the Publisher, API Publishing Services, 1220 L Street, NW, Washington, DC 20005.

*Copyright © 2013 American Petroleum Institute*

## Foreword

Nothing contained in any API publication is to be construed as granting any right, by implication or otherwise, for the manufacture, sale, or use of any method, apparatus, or product covered by letters patent. Neither should anything contained in the publication be construed as insuring anyone against liability for infringement of letters patent.

Shall: As used in a standard, “shall” denotes a minimum requirement in order to conform to the specification.

Should: As used in a standard, “should” denotes a recommendation or that which is advised but not required in order to conform to the specification.

This document was produced under API standardization procedures that ensure appropriate notification and participation in the developmental process and is designated as an API standard. Questions concerning the interpretation of the content of this publication or comments and questions concerning the procedures under which this publication was developed should be directed in writing to the Director of Standards, American Petroleum Institute, 1220 L Street, NW, Washington, DC 20005. Requests for permission to reproduce or translate all or any part of the material published herein should also be addressed to the director.

Generally, API standards are reviewed and revised, reaffirmed, or withdrawn at least every five years. A one-time extension of up to two years may be added to this review cycle. Status of the publication can be ascertained from the API Standards Department, telephone (202) 682-8000. A catalog of API publications and materials is published annually by API, 1220 L Street, NW, Washington, DC 20005.

Suggested revisions are invited and should be submitted to the Standards Department, API, 1220 L Street, NW, Washington, DC 20005, [standards@api.org](mailto:standards@api.org).



# Contents

	Page
<b>1</b>	<b>Scope</b> . . . . . <b>1</b>
<b>2</b>	<b>Normative References</b> . . . . . <b>1</b>
<b>3</b>	<b>Terms and Definitions</b> . . . . . <b>2</b>
<b>4</b>	<b>General</b> . . . . . <b>5</b>
<b>5</b>	<b>Proposals</b> . . . . . <b>7</b>
<b>6</b>	<b>Documentation</b> . . . . . <b>7</b>
<b>6.1</b>	<b>Approval Information</b> . . . . . <b>7</b>
<b>6.2</b>	<b>Final Records</b> . . . . . <b>9</b>
<b>7</b>	<b>Design</b> . . . . . <b>9</b>
<b>7.1</b>	<b>Tube Bundle Design</b> . . . . . <b>9</b>
<b>7.2</b>	<b>Air-side Design</b> . . . . . <b>23</b>
<b>7.3</b>	<b>Structural Design</b> . . . . . <b>35</b>
<b>8</b>	<b>Materials</b> . . . . . <b>39</b>
<b>8.1</b>	<b>General</b> . . . . . <b>39</b>
<b>8.2</b>	<b>Requirements for Carbon Steel in Sour or Wet Hydrogen Sulfide Service</b> . . . . . <b>40</b>
<b>8.3</b>	<b>Headers</b> . . . . . <b>40</b>
<b>8.4</b>	<b>Louvers</b> . . . . . <b>40</b>
<b>8.5</b>	<b>Other Components</b> . . . . . <b>41</b>
<b>9</b>	<b>Fabrication of Tube Bundle</b> . . . . . <b>41</b>
<b>9.1</b>	<b>Welding</b> . . . . . <b>41</b>
<b>9.2</b>	<b>Postweld Heat Treatment</b> . . . . . <b>42</b>
<b>9.3</b>	<b>Tube-to-Tubesheet Joints</b> . . . . . <b>42</b>
<b>9.4</b>	<b>Gasket Contact Surfaces</b> . . . . . <b>43</b>
<b>9.5</b>	<b>Thread Lubrication</b> . . . . . <b>44</b>
<b>9.6</b>	<b>Alignment and Tolerances</b> . . . . . <b>44</b>
<b>9.7</b>	<b>Assembly</b> . . . . . <b>44</b>
<b>10</b>	<b>Inspection, Examination, and Testing</b> . . . . . <b>44</b>
<b>10.1</b>	<b>Quality Control</b> . . . . . <b>44</b>
<b>10.2</b>	<b>Pressure Test</b> . . . . . <b>47</b>
<b>10.3</b>	<b>Shop Run-in</b> . . . . . <b>47</b>
<b>10.4</b>	<b>Equipment Performance Testing</b> . . . . . <b>47</b>
<b>10.5</b>	<b>Nameplates</b> . . . . . <b>47</b>
<b>11</b>	<b>Preparation for Shipment</b> . . . . . <b>48</b>
<b>11.1</b>	<b>General</b> . . . . . <b>48</b>
<b>11.2</b>	<b>Surfaces and Finishes</b> . . . . . <b>48</b>
<b>11.3</b>	<b>Identification and Notification</b> . . . . . <b>48</b>
<b>12</b>	<b>Supplemental Requirements</b> . . . . . <b>48</b>
<b>12.1</b>	<b>General</b> . . . . . <b>48</b>
<b>12.2</b>	<b>Design</b> . . . . . <b>49</b>
<b>12.3</b>	<b>Examination</b> . . . . . <b>49</b>
<b>12.4</b>	<b>Testing</b> . . . . . <b>50</b>

## Contents

	Page
<b>Annex A (informative) Recommended Practices</b> .....	<b>51</b>
<b>Annex B (informative) Checklist and Data Sheets</b> .....	<b>58</b>
<b>Annex C (informative) Winterization of Air-cooled Heat Exchangers</b> .....	<b>69</b>
<b>Annex D (informative) Recommended Procedure for Airflow Measurement of Air-cooled Heat Exchangers</b> .....	<b>120</b>
<b>Annex E (informative) Measurement of Noise from Air-cooled Heat Exchangers</b> .....	<b>128</b>
<b>Bibliography</b> .....	<b>146</b>
<b>Figures</b>	
<b>1 Typical Bay Arrangements</b> .....	<b>3</b>
<b>2 Typical Components of an Air-cooled Heat Exchanger</b> .....	<b>6</b>
<b>3 Typical Construction of Tube Bundles with Removable Cover Plate and Removable Bonnet Headers</b> .....	<b>14</b>
<b>4 Typical Confined and Full-faced Gasket Joint Details</b> .....	<b>15</b>
<b>5 Typical Construction of a Tube Bundle with Plug Headers</b> .....	<b>16</b>
<b>6 Nozzle Loads</b> .....	<b>20</b>
<b>7 Fan Dispersion Angle</b> .....	<b>25</b>
<b>8 Typical Drive Arrangements</b> .....	<b>31</b>
<b>9 Typical Plenum Arrangements</b> .....	<b>38</b>
<b>10 Standard Tolerances</b> .....	<b>45</b>
<b>C.1 System A — Airflow Control with Variable Speed Drives or Automatically Controlled Variable-pitch Fans</b> .....	<b>76</b>
<b>C.2 System A — Airflow Control with Automatically Controlled Outlet Louvers and Fixed-pitch Fans</b> .....	<b>77</b>
<b>C.3 System B — Induced Draught with Non-contained Internal Air Recirculation</b> .....	<b>77</b>
<b>C.4 System B — Forced Draught with Non-contained Internal Air Recirculation</b> .....	<b>78</b>
<b>C.5 System C — Typical Forced-draught Air-cooled Heat Exchanger with Contained Internal Air Recirculation</b> .....	<b>78</b>
<b>C.6 System D — Typical Forced-draught Air-cooled Heat Exchanger with External Air Recirculation</b> .....	<b>79</b>
<b>C.7 Freezing Points of Phenol-water Solutions</b> .....	<b>84</b>
<b>C.8 Freezing Points of Ethanolamine-water Solutions</b> .....	<b>84</b>
<b>C.9 Freezing Points of Glycerol-water Solutions</b> .....	<b>85</b>
<b>C.10 Dissociation Constant of Ammonium Bisulfide (NH<sub>4</sub>HS)</b> .....	<b>86</b>
<b>C.11 Hydrate Pressure-temperature Equilibria</b> .....	<b>87</b>
<b>C.12 Tempered-water System</b> .....	<b>98</b>
<b>D.1 Static Pressure Probe Locations</b> .....	<b>122</b>
<b>D.2 Location of Measurement Points</b> .....	<b>123</b>
<b>E.1 Isolated Single Bay Noise Measurement Points</b> .....	<b>131</b>
<b>E.2 <i>L<sub>p</sub></i> Measurement Locations Forced — Draught Unit (2-fan Bay)</b> .....	<b>139</b>
<b>E.3 <i>L<sub>p</sub></i> Measurement Locations Induced — Draught Unit (2-fan Bay)</b> .....	<b>140</b>
<b>Tables</b>	
<b>1 Minimum Nominal Thickness of Header Components</b> .....	<b>12</b>
<b>2 Minimum Flange Bolt Spacing</b> .....	<b>15</b>
<b>3 Minimum Nozzle Neck Nominal Thickness</b> .....	<b>18</b>

## Contents

	Page	
4	Maximum Allowable Nozzle Loads . . . . .	20
5	Minimum Required Wall Thickness of Tubes . . . . .	21
6	Radial Clearances . . . . .	26
7	Dry-air Standard Conditions . . . . .	27
8	Minimum Thickness of Expanded Metal Fan Guard Mesh . . . . .	28
9	Maximum Allowable Louver Deflection . . . . .	33
10	Live Loads on Platforms, Columns and Walkways . . . . .	36
11	Nominal Tube Hole Diameters and Tolerances . . . . .	43
12	Maximum Weld Hardness . . . . .	46
A.1	Maximum Fin Selection Temperature for Fin Bonding Types . . . . .	52
A.2	Header Selection . . . . .	53
A.3	Gasket Types . . . . .	55
A.4	Gasket Contact-surface Finish . . . . .	55
A.5	Service Conditions . . . . .	56
A.6	Gasket Selection . . . . .	56
C.1	Safety Margins for Different Process Categories . . . . .	73
C.2	Freezing Points of Frequently Encountered Liquid Pure Components . . . . .	83
C.3	Description of Indirect and Direct Air Cooling Systems (SI Units) . . . . .	99
C.4	Description of Indirect and Direct Air Cooling Systems (US Customary Units) . . . . .	99
C.5	Comparison of Costs of Indirect and Direct Air Cooling Systems . . . . .	100
C.6	Values for $r_m$ Referred to the Total Outside Area for a Tube with an Outside Diameter of 25.4 mm and Aluminum Fins 15.9 mm High and 0.4 mm Thick . . . . .	102
C.7	Values for $r_m$ Referred to the Total Outside Area for a Tube with an Outside Diameter of 1 in. and Aluminum Fins $5/8$ in. High and 0.016 in. Thick . . . . .	106
D.1	Instruments . . . . .	120
D.2	Location of Measurement Points . . . . .	123
E.1	Required Instrumentation and Applicable Specifications . . . . .	128
E.2	Symbols and Abbreviations . . . . .	129
E.3	Isolated Single Bay Noise Measurement Points . . . . .	132
E.4	Background Correction Values . . . . .	133
E.5	Background Correction Values — Example for One Measurement Point “X” . . . . .	133
E.6	Background Noise Correction Values . . . . .	141
E.7	Background Noise Correction Values — Example Using One Measurement Point “X” . . . . .	141
E.8	Background Noise Correction Values — Example Using Measurement Point “n” . . . . .	141
E.9	Background Noise Correction Values . . . . .	143
E.10	Background Noise Correction Values — Example Using One Measurement Point “X” . . . . .	143
E.11	Background Noise Correction Values — Example Using Measurement Point “n” . . . . .	143



## Introduction

It is necessary that users of this standard be aware that further or differing requirements can be needed for individual applications. This standard is not intended to inhibit a Vendor from offering, or the Purchaser from accepting, alternative equipment or engineering solutions for the individual application. This can be particularly applicable where there is innovative or developing technology. Where an alternative is offered, it is the responsibility of the Vendor to identify any variations from this standard and provide details.



# Petroleum, Petrochemical, and Natural Gas Industries—Air-cooled Heat Exchangers

## 1 Scope

This standard gives requirements and recommendations for the design, materials, fabrication, inspection, testing, and preparation for shipment of air-cooled heat exchangers for use in the petroleum, petrochemical, and natural gas industries.

This standard is applicable to air-cooled heat exchangers with horizontal bundles, but the basic concepts can also be applied to other configurations.

## 2 Normative References

The following referenced documents are indispensable for the application of this document. For dated references, only the edition cited applies. For undated references, the latest edition of the referenced document (including any amendments) applies.

AGMA 6001 <sup>1</sup>, *Design and Selection of Components for Enclosed Gear Drives*

ANSI/AGMA 6010, *Spur, Helical, Herringbone and Bevel Enclosed Drives*

ASME PTC 30 <sup>2</sup>, *Air-Cooled Heat Exchangers*

ICC <sup>3</sup>, *International Building Code*

ISO 76 <sup>4</sup>, *Rolling bearings — Static load ratings*

ISO 281, *Rolling bearings — Dynamic load ratings and rating life*

ISO 286 (all parts), *Geometrical product specifications (GPS) — ISO code system for tolerances on linear sizes*

ISO 1081, *Belt drive — V-belts and V-ribbed belts, and corresponding grooved pulleys — Vocabulary*

ISO 1461, *Hot-dip galvanized coatings on fabricated iron and steel articles — Specifications and test methods*

ISO 2491, *Thin parallel keys and their corresponding keyways (dimensions in millimeters)*

ISO 4183, *Belt drives — Classical and narrow V-belts — Grooved pulleys (system based on datum width)*

ISO 4184, *Belt drives — Classical and narrow V-belts — Lengths in datum system*

ISO 5287, *Belt drives — Narrow V-belts for the automotive industry — Fatigue test*

---

<sup>1</sup> American Gear Manufacturers Association, 1001 N. Fairfax Street, Suite 500, Alexandria, Virginia 22314, [www.agma.org](http://www.agma.org).

<sup>2</sup> American Society of Mechanical Engineers, Two Park Avenue, New York, NY 10016-5990, [www.asme.org](http://www.asme.org).

<sup>3</sup> International Code Council, 500 New Jersey Avenue, NW, 6th Floor, Washington, DC 20001, [www.iccsafe.org](http://www.iccsafe.org).

<sup>4</sup> International Organization for Standardization, 1, ch. de la Voie-Creuse, Case postale 56, CH-1211, Geneva 20, Switzerland, [www.iso.org](http://www.iso.org).

ISO 5290, *Belt drives — Grooved pulleys for joined narrow V-belts — Groove sections 9N/J, 15N/J and 25N/J (effective system)*

ISO 8501-1, *Preparation of steel substrates before application of paints and related products — Visual assessment of surface cleanliness — Part 1: Rust grades and preparation grades of uncoated steel substrates and of steel substrates after overall removal of previous coatings*

ISO 9563, *Belt drives — Electrical conductivity of antistatic endless synchronous belts — Characteristics and test method*

ISO 15156 (all parts), *Petroleum and natural gas industries — Materials for use in H<sub>2</sub>S-containing environments in oil and gas production*

NACE MR0103<sup>5</sup>, *Materials Resistant to Sulfide Stress Cracking in Corrosive Petroleum Refining Environments*

NACE SP0472, *Methods and Controls to Prevent In-Service Environmental Cracking of Carbon Steel Weldments in Corrosive Petroleum Refining Environments*

### 3 Terms and Definitions

For the purposes of this document, the following terms and definitions apply.

#### 3.1

##### **bank**

One or more items arranged in a continuous structure.

#### 3.2

##### **bare tube surface**

Total area of the outside surfaces of the tubes, based on the length measured between the outside faces of the header tubesheets.

#### 3.3

##### **bay**

One or more tube bundles, serviced by two or more fans, including the structure, plenum and other attendant equipment.

NOTE Figure 1 shows typical bay arrangements.

#### 3.4

##### **critical process temperature**

Temperature related to important physical properties of a process stream.

EXAMPLES Freezing point, pour point, cloud point, hydrate formation temperature, and dew point.

#### 3.5

##### **cyclic service**

Process operation with periodic variation in temperature, pressure, and/or flowrate.

---

<sup>5</sup> NACE International (formerly the National Association of Corrosion Engineers), 1440 South Creek Drive, Houston, Texas 77218-8340, [www.nace.org](http://www.nace.org).

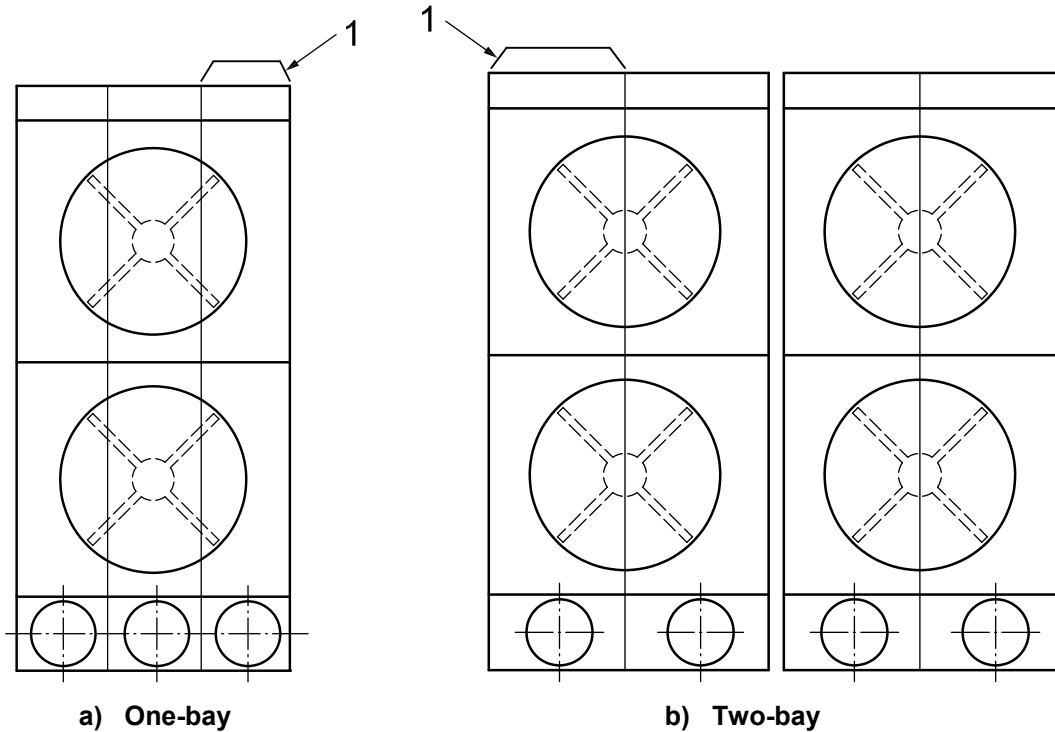

**Key**

1 tube bundle

**Figure 1 — Typical Bay Arrangements**

**3.6  
exhaust air**

Air that is discharged from the air-cooled heat exchanger to the atmosphere.

**3.7  
external recirculation**

Process that uses an external duct to carry recirculated air to mix with and heat the inlet air.

**3.8  
finned surface**

Total area of the outside surface (finned surface) on a finned tube exposed to air.

**3.9  
forced-draught exchanger**

Exchanger designed with the tube bundles located on the discharge side of the fan.

**3.10  
geometric center**

Location at the center of a bay on a plane midway between the air inlet and the air outlet for both forced-draft and induced-draft units.

NOTE The geometric center is also considered the acoustic center of a bay for calculations.

**3.11  
hydrogen service**

Services that contain hydrogen at a partial pressure exceeding 700 kPa (100 psi) absolute.

**3.12****induced-draught exchanger**

Exchanger designed with the tube bundles located on the suction side of the fan.

**3.13****inlet air**

Atmospheric or ambient air that enters the air-cooled heat exchanger.

**3.14****internal recirculation**

Process that uses fans (possibly with louvers) to recirculate air from one part of the process bundle to the other part.

**3.15****item**

One or more tube bundles for an individual service.

**3.16****item number**

Purchaser's identification number for an item.

**3.17****measurement surface**

Surface of the bay or the cylinder or sphere on which sound-pressure level is measured.

**3.18****minimum design air temperature**

Specified inlet air temperature that is used for winterization.

**3.19****minimum design metal temperature**

Lowest metal temperature at which pressure-containing elements can be subjected to design pressure.

**3.20****octave bands**

Preferred frequency bands.

**3.21****pressure design code**

Recognized pressure vessel standard specified or agreed by the Purchaser.

EXAMPLE ASME BPVC VIII.

**3.22****recirculated air**

Air that has passed through the process bundle and is redirected to mix with and heat the inlet air.

**3.23****specified minimum tube-wall temperature**

Critical process temperature plus a safety margin.

**3.24****structural code**

Recognized structural standard specified or agreed by the Purchaser.

EXAMPLES AISC M011 and AISC S302.

**3.25****tube bundle**

Assembly of headers, tubes and frames.

**3.26****seal-welded**

Tube-to-tubesheet joint weld of unspecified strength applied between the tubes and tubesheets for the sole purpose of reducing the potential for leakage.

**3.27****sound level**

Sound-pressure level when frequency is weighted according to the standardized A, B, or C weighting used in sound-level meters.

NOTE Only A-weighted readings [dB(A)] are referenced in this standard.

**3.28****sound-power level**

Ten times the logarithm to base 10 of the ratio of the total acoustic power radiated by a sound source to the reference power of  $10^{-12}$  W.

**3.29****sound-pressure level**

Twenty times the logarithm to base 10 of the ratio of the root mean square sound pressure to the reference sound pressure of  $2 \times 10^{-5}$  N/m<sup>2</sup>.

**3.30****strength-welded**

Tube-to-tubesheet joint welded so that the design strength is equal to, or greater than, the axial tube strength specified by the pressure design code.

**3.31****unit**

One or more tube bundles in one or more bays for an individual service.

**3.32****wind skirt**

Vertical barrier either above or below an air-cooled heat exchanger that minimizes the effect of wind.

**3.33****winterization**

Provision of design features, procedures, or systems for air-cooled heat exchangers to avoid problems with the process fluid as a result of low-temperature inlet air.

NOTE Problems related to low-temperature inlet air include fluid freezing, cooling to the pour point, wax formation, hydrate formation, laminar flow, and condensation at the dew point (which can initiate corrosion).

**4 General**

- **4.1** The pressure design code shall be specified or agreed by the Purchaser.

Pressure components shall comply with the pressure design code and the supplemental requirements given in this standard.

NOTE A bullet (●) at the beginning of a subsection indicates a requirement for the Purchaser to make a decision or provide information (see checklist in Annex B).

**4.2** The air-cooled heat exchanger shall be either a forced-draught exchanger or an induced-draught exchanger and shall include the components shown in Figure 2 and any auxiliaries such as ladders, walkways and platforms (see A.2).

**4.3** Annex A, which may be consulted if required, includes recommended mechanical and design details. Annex A also includes precautions for consideration when specifying certain design aspects, including temperature limitations, type of extended surface, tube support methods, type of air-cooled heat exchanger, materials of gasket construction and operational considerations such as walkway access.

- **4.4** The Vendor shall comply with the applicable local regulations specified by the Purchaser.

**4.5** In this standard, where practical, US Customary (USC) and other commonly used units are included in brackets.

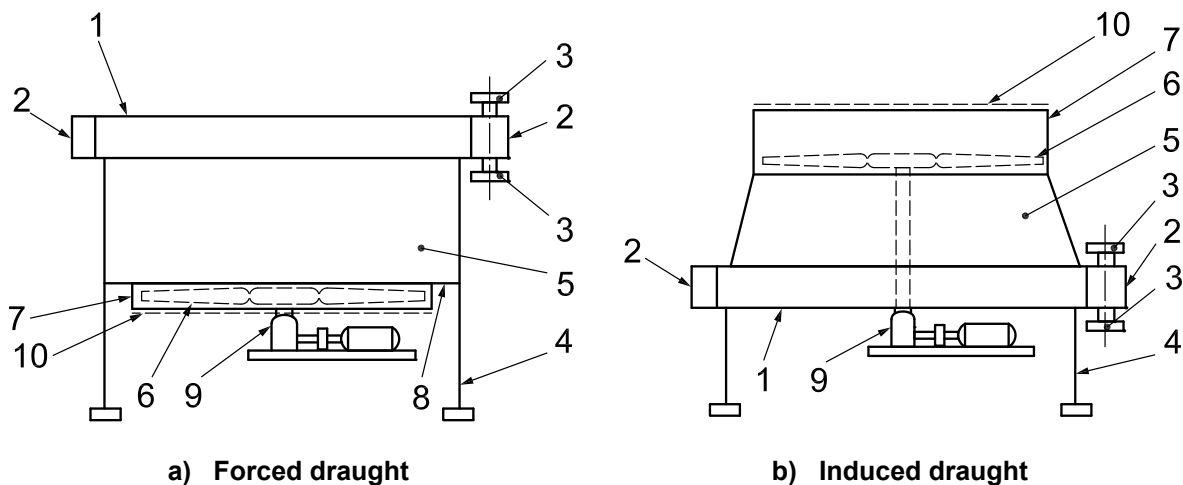

**Key**

1	tube bundle	6	fan
2	header	7	fan ring
3	nozzle	8	fan deck
4	supporting column	9	drive assembly
5	plenum	10	fan guard

**Figure 2 — Typical Components of an Air-cooled Heat Exchanger**

- **4.6** The Purchaser shall specify if the service is designated as sour in accordance with ISO 15156 (all parts) for oil and gas production facilities and natural gas sweetening plants, or designated as wet hydrogen sulfide service in accordance with NACE MR0103 for other applications (e.g. petroleum refineries, LNG plants and chemical plants), in which case all materials in contact with the process fluid shall meet the requirements of the applicable NACE standard to mitigate the potential for sulfide stress cracking (SSC). Identification of the complete set of materials, qualification, fabrication, and testing specifications to prevent in-service environmental cracking is the responsibility of the user (Purchaser).

**NOTE** For the purpose of this provision, NACE MR0175 is equivalent to ISO 15156 (all parts).

- **4.7** The requirement for winterization and its type shall be specified by the Purchaser. Annex C contains guidance on various methods of winterization for air-cooled heat exchangers.

## **5 Proposals**

- 5.1** The Vendor's proposal shall include a completed data sheet for each item (see example in Annex B).
- 5.2** A proposal drawing that shows the major dimensions in plan and elevation, and the nozzle sizes and their orientation shall be furnished.
- 5.3** The proposal shall state whether vertically mounted electric motors shall be shaft up or shaft down.
- 5.4** The proposal shall fully define the extent of shop assembly and include a general description of the components for assembly in the field.
- 5.5** Any proposal for a design that is not fully described in this standard shall include additional drawings sufficient to describe the details of construction.
- 5.6** The proposal shall include a detailed description of any exceptions to the specified requirements.
- **5.7** The proposal shall include noise data. The proposal shall include a noise data sheet (see example in Annex B) if specified by the Purchaser.
- 5.8** The proposal shall include fan performance characteristic curves with the design point marked on the curves.
- 5.9** The proposal shall include details of the method used to secure the fin ends; see 7.1.11.7.
- 5.10** The proposal for an air-cooled exchanger with a recirculation system (as described in Annex C) shall include drawings showing the duct and plenum sizes, net free flow area, louver type and arrangement, drive location, and proposed control schematic.

## **6 Documentation**

### **6.1 Approval Information**

- **6.1.1** For each item number, the Vendor shall produce documents that include the following information. The Purchaser shall specify which documents shall be submitted and which of them shall be subject to approval:
  - a) Purchaser's item number, service, project name and location, Purchaser's order number, and Vendor's shop order number;
  - b) design pressure, maximum allowable working pressure, test pressure, maximum and minimum design temperature, and corrosion allowance;
  - c) fan performance characteristic curves with the design point marked on the curve, including fan critical speeds for use with variable-frequency drives;
  - d) any applicable codes and purchase specifications of the Purchaser;
  - e) material specifications and grades for all pressure parts;

- f) overall dimensions;
- g) dimensions and locations of supports and sizes of hold-down bolts;
- h) nozzle size, rating, facing, location, projection beyond header surface, allowable loadings (forces and moments) and direction of flow;
- i) drive mount details;
- j) masses of the tube bundle, the exchanger empty and full of water, and the mass of the heaviest component (or combination of components) intended by the Vendor for handling in a single lift;
- k) column reactions for each load type listed in 7.3.3;
- l) post-weld heat treatment requirements;
- m) U-bend heat treatment or annealing procedure;
- n) radiographic and other non-destructive examination requirements;
- o) surface preparation and painting requirements;
- p) design exposure temperatures for mechanical and instrumentation components;
- q) nameplate and its position;
- r) tube-to-tubesheet joint and details of joint preparation;
- s) maximum and minimum plug torque values with recommended thread lubrication;
- t) when sour or wet sulfide service is specified by the Purchaser, a certified material test report (CMTR) shall be supplied for all carbon steel materials in contact with the process fluid.

**6.1.2** The Vendor shall also furnish gasket detail drawings, field assembly drawings, and drawings for all auxiliary equipment and controls furnished. Drawings shall show electrical and control connections, including those of motive and signal air for any pneumatically actuated louvers or fans. The gasket details shall include type and material, and shall be shown on a separate drawing.

- **6.1.3** If specified by the Purchaser, calculations required by the pressure design code shall be provided for the design of pressure components, including header boxes, tubes and tube joints. Sufficient detail shall be supplied for any non-standard pressure boundary components, such as swage type transition nozzles. Calculations shall also be provided for restraint relief in accordance with 7.1.6.1.3, and also for the defined external moments and forces on nozzles in accordance with 7.1.10.
- **6.1.4** If specified by the Purchaser, weld maps, all proposed welding procedures, including tube to tubesheet welding procedures and qualifications (including impact test results, if applicable), shall be submitted for approval prior to fabrication.
- **6.1.5** If a hot air recirculation system is utilized for winterization, documents showing duct and plenum sizes, net free flow areas, louver types and arrangement, louver drive location(s), heating coil and heating medium consumption, and control scheme schematic shall be provided.
- **6.1.6** Further engineering information required from the Vendor for installation, operation, maintenance, or inspection shall be a matter of agreement between the Purchaser and the Vendor.

## 6.2 Final Records

**6.2.1** The Vendor shall maintain records of the materials used and fabrication details for at least 10 years.

- **6.2.2** The Purchaser shall specify which of the following shall be furnished, and shall specify if any of them shall be in an electronic medium:
  - a) “as-built” data sheet, including material specifications and grades for all pressure parts;
  - b) as-built shop drawings including details of headers and tube bundles; as-built shop drawings shall also be provided for any heating coils;
  - c) calculations as required by the pressure design code, including nozzle load confirmation, restraint relief and any finite element analysis;
  - d) certified motor drawing and completed motor data sheet for each size and type of motor;
  - e) manufacturer's data report in accordance with the pressure design code;
  - f) certified material test reports for all pressure parts;
  - g) fan and hub data, including shaft bore and keyway dimensions and coupling and sheave data;
  - h) schematic diagram for automatically controlled fan pitch or louver blade adjustment, if the controller is furnished by the Vendor;
  - i) installation, operation and maintenance instructions, including the type of lubrication furnished for gears and bearings;
  - j) parts list;
  - k) certified noise data sheet for the air-cooled heat exchanger with the fans operating at rated speed and at design conditions;
  - l) fan performance characteristic curves showing the operating point and shaft power consumption;
  - m) louver characteristic performance curve;
  - n) temperature recorder charts made during postweld heat treatment of the headers;
  - o) non-destructive testing records;
  - p) nameplate rubbing or facsimile.

## 7 Design

### 7.1 Tube Bundle Design

#### 7.1.1 General

**7.1.1.1** Tube bundles shall be rigid, self-contained, and designed for handling as a complete assembly.

**7.1.1.2** The Vendor shall make provision for lateral movement of exchanger tube bundles of at least 6 mm ( $1/4$  in.) in both directions or 12.7 mm ( $1/2$  in.) in only one direction, unless the Purchaser and the Vendor agree on a different value.

**7.1.1.3** Provision shall be made to accommodate thermal expansion of tubes.

**7.1.1.4** All tubes shall be supported to prevent sagging and meshing or deformation of fins. Tube supports shall be spaced not more than 1.83 m (6 ft) from center to center.

**7.1.1.5** A hold-down member (tube keeper) shall be provided at each tube support. Hold-down members shall be attached to side frames by bolting.

**7.1.1.6** Tubes of single-pass condensers shall be sloped downward at least 10 mm/m ( $1/8$  in./ft) towards the outlet header.

**7.1.1.7** The last pass of tubes in multi-pass condensers shall be sloped downward at least 10 mm/m ( $1/8$  in./ft) towards the outlet header (see A.3.1).

**7.1.1.8** Air seals shall be provided throughout the tube bundle and the bay to minimize air leakage and bypassing. Any air gap that exceeds 10 mm ( $3/8$  in.) in width shall be sealed.

**7.1.1.9** The minimum thickness of metal used for air seal construction shall be 2.7 mm (12 gauge USS; 0.105 in.) within the bundle side frame and 1.9 mm (14 gauge USS; 0.08 in.) outside the bundle side frame.

NOTE USS is US Standard for sheet and plate iron and steel.

**7.1.1.10** Bolts for removable air seals shall be at least 10 mm ( $3/8$  in.) nominal diameter.

- **7.1.1.11** The exchanger shall be designed for an internal steam-out operation at the temperature, pressure, and operating conditions if specified by the Purchaser.
- **7.1.1.12** The Purchaser shall specify if cyclic service design is required. If cyclic service is specified, the Purchaser shall specify the type and magnitude of variation in pressure, temperature and flowrate, the time for the variation (hours, weeks, etc.) and the number of cycles or frequency for this variation expected during the life of the equipment. The extent and acceptance criteria of any required analysis shall be subject to the agreement of the Purchaser (see A.3.2).

## **7.1.2 Heating Coils**

**7.1.2.1** Heating coils provided to protect the tube bundle against freeze-up shall be in a separate bundle, and not part of the tube bundle.

**7.1.2.2** Heating coils shall cover the full width of the tube bundle.

**7.1.2.3** The tube pitch of the heating coil shall not exceed the smaller of twice the tube pitch of the tube bundle or 4.75 times the nominal heating coil tube diameter.

**7.1.2.4** If steam is used as heating fluid, heating coils shall be single pass, and the tubes shall be sloped downward at least 10 mm/m ( $1/8$  in./ft) towards the outlet.

**7.1.2.5** Pipe-type headers with welded-in tubes may be used for steam service.

### 7.1.3 Design Temperature

- **7.1.3.1** The maximum and minimum design temperatures for pressure parts shall be as specified by the Purchaser.
- **7.1.3.2** The Purchaser shall separately specify the maximum operating temperature to apply for fin type selection (the fin design temperature). The design temperatures for pressure parts are not intended to govern fin type selection or to apply in determining exposure temperatures of mechanical and instrumentation components.

### 7.1.4 Design Pressure

- The design pressure shall be as specified by the Purchaser.

### 7.1.5 Corrosion Allowance

- **7.1.5.1** The corrosion allowance shall be as specified by the Purchaser for all surfaces exposed to the process fluid, except that no corrosion allowance shall be provided for tubes, gaskets or gasket contact surfaces. If not specified, a minimum corrosion allowance of 3 mm ( $1/8$  in.) shall be provided for carbon and low-alloy steel components.

**7.1.5.2** The corrosion allowance shall be provided on each side of pass partition plates or stiffeners.

**7.1.5.3** A thickness equal to the depth of the pass partition groove may be considered as available corrosion allowance on grooved cover plate and tubesheet surfaces.

### 7.1.6 Headers

#### 7.1.6.1 General

- **7.1.6.1.1** Headers shall be designed to prevent excessive warpage of tubesheets and/or leakage at tube joints. The analysis shall consider maximum operating temperature and maximum cooling conditions at minimum ambient air temperature. If specified by the Purchaser, the analysis shall consider alternative operations such as low process flow at low ambient air temperature, freezing of fluids in tubes, steam-out, loss of fans due to power failure, and cyclic conditions.

**7.1.6.1.2** If the fluid temperature difference between the inlet and the outlet of a multi-pass bundle exceeds 110 °C (200 °F), U-tube construction, split headers or other methods of restraint relief shall be employed.

**7.1.6.1.3** The requirement for restraint relief in single- or multi-pass exchangers shall be investigated regardless of the fluid temperature difference between the inlet and outlet of the exchanger. The Vendor shall provide calculations to prove the adequacy of the design. Some of the stresses are additive, and tube-to-tubesheet joint efficiency shall be considered. Calculations shall consider the following stress combinations:

a) for tube stress and/or tube-to-tubesheet joint stress:

- 1) stress caused by differential tube expansion between rows/passes in the coil sections in both clean and fouled conditions,
- 2) stress caused by pressure,
- 3) stress caused by nozzle forces and moments,
- 4) stress caused by lateral header movement;

b) for header and nozzle stress:

- 1) stress caused by temperature and pressure,
- 2) stress caused by nozzle forces and moments,

NOTE Forces and moments can induce movement of the header; see note in 7.1.10.2.

- 3) stress caused by differential tube expansion between rows/passes in the coil sections;

c) for header attachments and supports (including coil side frames and cooler structure):

- 1) stress caused by mass of the header full of water,
- 2) stress caused by nozzle forces and moments,

NOTE Forces and moments can induce movement of the header; see note in 7.1.10.2.

- 3) stress caused by tube expansion.

NOTE There can be additional loads and stresses imposed on the tube bundle that have not been mentioned above (e.g. seismic).

**7.1.6.1.4** Headers shall be designed so that the corresponding cross-sectional flow area of each pass is at least 100 % of the flow area in the following tube pass.

**7.1.6.1.5** The lateral velocity in the header inlet compartment shall not exceed the velocity in the inlet nozzle. Multiple nozzles or an increased header cross-sectional area can be required.

**7.1.6.1.6** The minimum nominal thickness of header components shall be as shown in Table 1.

**Table 1 — Minimum Nominal Thickness of Header Components**

Component	Minimum Thickness	
	Carbon or Low-alloy Steel mm (in.)	High-alloy Steel or Other Material mm (in.)
Tubesheet	19 ( <sup>3</sup> / <sub>4</sub> )	16 ( <sup>5</sup> / <sub>8</sub> )
Plug sheet	19 ( <sup>3</sup> / <sub>4</sub> )	16 ( <sup>5</sup> / <sub>8</sub> )
Top, bottom and end plates	12 ( <sup>1</sup> / <sub>2</sub> )	10 ( <sup>3</sup> / <sub>8</sub> )
Removable cover plates	25 (1)	22 ( <sup>7</sup> / <sub>8</sub> )
Pass partition plates and stay plates	12 ( <sup>1</sup> / <sub>2</sub> )	6 ( <sup>1</sup> / <sub>4</sub> )
NOTE The thickness indicated for any carbon or low-alloy steel component includes a corrosion allowance of up to 3 mm ( <sup>1</sup> / <sub>8</sub> in.). The thickness indicated for any component of high-alloy steel or other material does not include a corrosion allowance. The thickness is based on an expanded tube-to-tubesheet joint with one groove.		

**7.1.6.1.7** Pass partitions used as stay plates for the tubesheet and plug sheet shall be made of one integral plate.

**7.1.6.1.8** Header types other than those described in 7.1.6.2 or 7.1.6.3 may be proposed as an alternative design (see Section 12).

### 7.1.6.2 Removable Cover Plate and Removable Bonnet Headers

**7.1.6.2.1** The cover plate header design shall permit removal of the cover without disturbing header piping connections. Figure 3 a) shows the typical construction of tube bundles with removable cover plate headers.

**7.1.6.2.2** The bonnet header design shall permit removal of the bonnet with the minimum dismantling of header piping connections. Figure 3 b) shows typical construction of tube bundles with removable bonnet headers.

**7.1.6.2.3** Bolted joints shall be designed using through bolts with either confined gaskets or unconfined full-face gaskets. Stud bolt construction may be used if approved by the Purchaser. Gasket contact surfaces on cover plates, matching header box flanges and tubesheets shall be machined. The surface finish shall be appropriate for the type of gasket (See A.3.12). Typical constructions are shown in Figure 4. For hydrogen, sour, or wet hydrogen sulfide service, only confined gasket construction shall be used [see Figure 4 a) or 4 b)].

**7.1.6.2.4** Either jackscrews or a minimum clearance of 5 mm ( $^3/16$  in.) shall be provided at the cover periphery to facilitate dismantling.

**7.1.6.2.5** Stay-bolts shall not be used.

**7.1.6.2.6** For stud type construction, provision (e.g. sliding pins) shall be made to prevent damage to the studs during handling of the cover plate.

**7.1.6.2.7** The minimum nominal diameter of through-bolts shall be 16 mm ( $^5/8$  in.). The minimum nominal diameter of stud bolts shall be 20 mm ( $^3/4$  in.).

**7.1.6.2.8** The maximum spacing between bolt centers shall be in accordance with the pressure design code.

**7.1.6.2.9** The minimum spacing between bolt centers shall be as shown in Table 2.

**7.1.6.2.10** Spacing between bolts straddling corners shall be such that the diagonal distance between bolts adjacent to the corner does not exceed the lesser of the spacing on the sides or the ends.

**7.1.6.2.11** Allowable stresses that have been established on the basis of short-time tensile strength shall not be used for the design of flanges and gasketed flat covers.

NOTE 1 These allowable stresses can cause permanent deformation.

NOTE 2 In ASME BPVC II, the allowable stresses of some stainless steel alloys and high-nickel alloys have been established in this way.

### 7.1.6.3 Plug Headers

**7.1.6.3.1** Threaded plug holes shall be provided opposite the ends of each tube for access. Holes shall be threaded to the full depth of the plug sheet. Figure 5 shows typical construction of a tube bundle with plug headers.

**7.1.6.3.2** The nominal thread diameter of the plug holes shall be equal to the outside diameter of the tube plus at least 3 mm ( $^1/8$  in.).

**7.1.6.3.3** Gasket contact surfaces of plug holes shall be spot-faced. The edges of the facing shall be free of burrs.

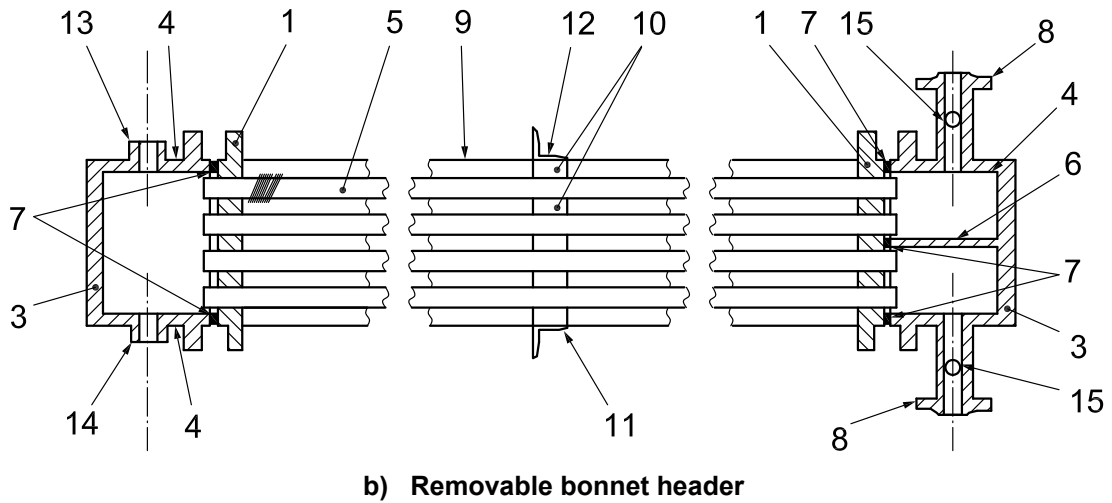
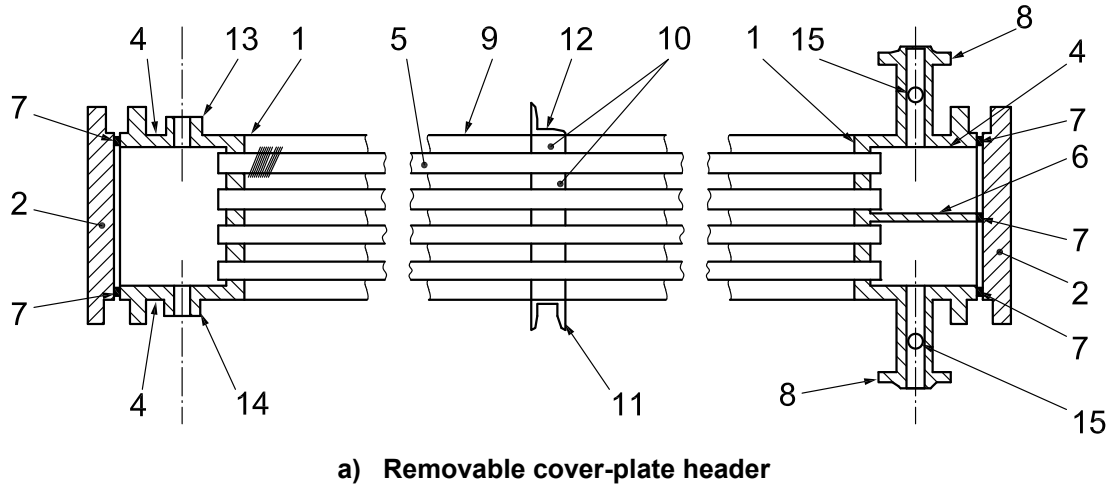

**Key**

1	tubesheet	6	pass partition	11	tube support cross-member
2	removable cover plate	7	gasket	12	tube keeper
3	removable bonnet	8	nozzle	13	vent
4	top and bottom plates	9	side frame	14	drain
5	tube	10	tube spacer	15	instrument connection

**Figure 3 — Typical Construction of Tube Bundles with Removable Cover Plate and Removable Bonnet Headers**

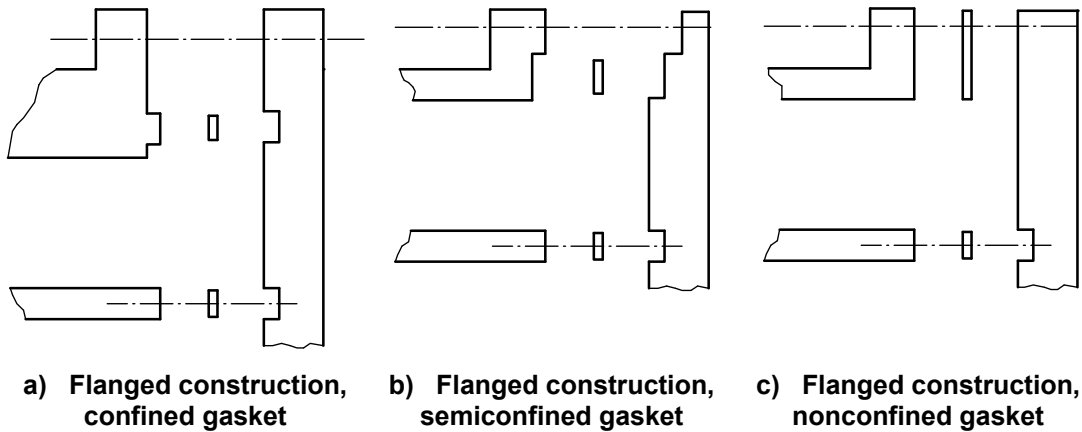

Figure 4 — Typical Confined and Full-faced Gasket Joint Details

Table 2 — Minimum Flange Bolt Spacing

Nominal Bolt Diameter mm (in.)	Minimum Bolt Spacing mm (in.)
16 ( <sup>5</sup> / <sub>8</sub> )	38 (1 <sup>1</sup> / <sub>2</sub> )
19 ( <sup>3</sup> / <sub>4</sub> )	44 (1 <sup>3</sup> / <sub>4</sub> )
22 ( <sup>7</sup> / <sub>8</sub> )	52 (2 <sup>1</sup> / <sub>16</sub> )
25 (1)	57 (2 <sup>1</sup> / <sub>4</sub> )
29 (1 <sup>1</sup> / <sub>8</sub> )	64 (2 <sup>1</sup> / <sub>2</sub> )
32 (1 <sup>1</sup> / <sub>4</sub> )	71 (2 <sup>13</sup> / <sub>16</sub> )
35 (1 <sup>3</sup> / <sub>8</sub> )	76 (3 <sup>1</sup> / <sub>16</sub> )
38 (1 <sup>1</sup> / <sub>2</sub> )	83 (3 <sup>1</sup> / <sub>4</sub> )
41 (1 <sup>5</sup> / <sub>8</sub> )	89 (3 <sup>1</sup> / <sub>2</sub> )
44 (1 <sup>3</sup> / <sub>4</sub> )	95 (3 <sup>3</sup> / <sub>4</sub> )
48 (1 <sup>7</sup> / <sub>8</sub> )	102 (4)
51 (2)	108 (4 <sup>1</sup> / <sub>4</sub> )

**7.1.7 Plugs for Tube Access**

7.1.7.1 Plugs shall be the shoulder type with straight-threaded shanks.

7.1.7.2 Hollowed plugs shall not be used.

7.1.7.3 Plugs shall have hexagonal heads. The minimum dimension across the flats shall be at least equal to the plug shoulder diameter.

7.1.7.4 The pressure seal shall be maintained by means of a gasket between the plug flange and the plug sheet.

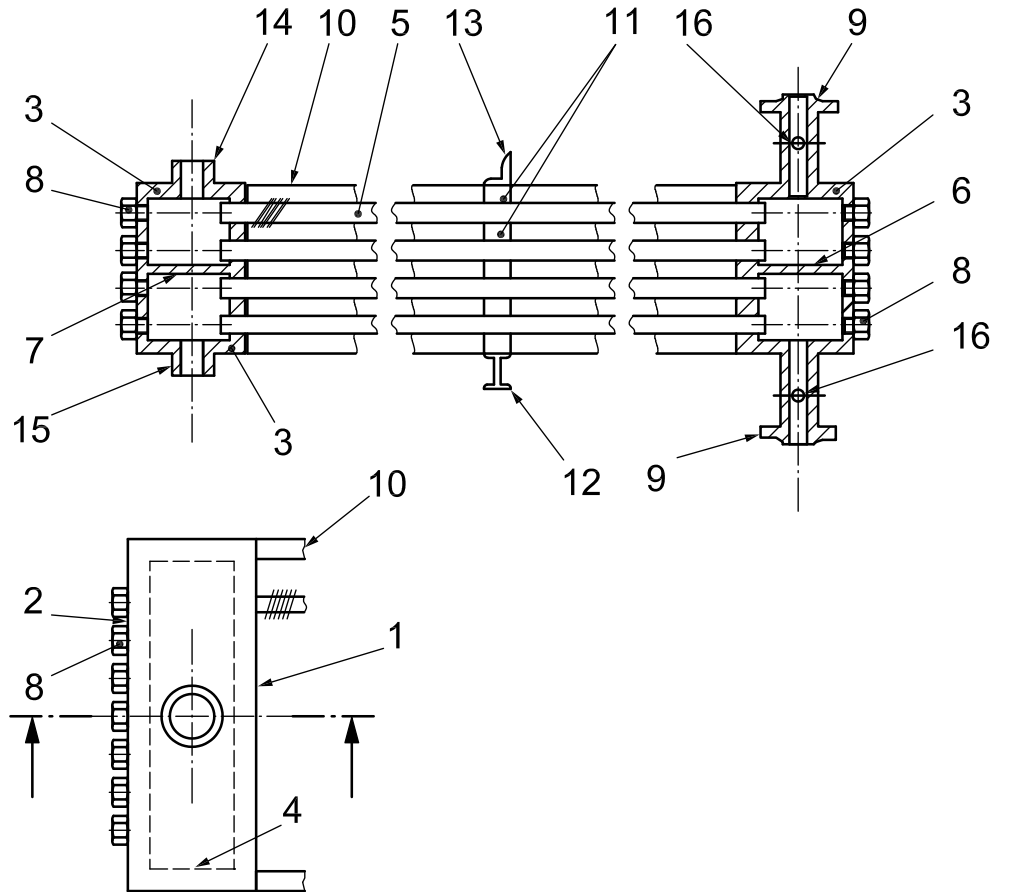

**Key**

1	tubesheet	7	stiffener	13	tube keeper
2	plug sheet	8	plug	14	vent
3	top and bottom plates	9	nozzle	15	drain
4	end plate	10	side frame	16	instrument connection
5	tube	11	tube spacer		
6	pass partition	12	tube support cross-member		

**Figure 5 — Typical Construction of a Tube Bundle with Plug Headers**

**7.1.7.5** Positive means (such as a self-centering taper) shall be provided to ensure seating of the gasket in the spot-faced recess.

**7.1.7.6** Plugs shall be long enough to fill the plug sheet threads, with a tolerance of  $\pm 1.5$  mm ( $1/16$  in.), except for galling materials or if the nominal plug sheet thickness is greater than 50 mm (2 in.), for which alternative designs may be used with the approval of the Purchaser. Additional factors to consider in selecting the plug design are thread interference, erosion, crevice corrosion and retention of fluid in cavities.

**7.1.7.7** The thickness of the plug head from its gasket surface to the top face shall be at least 50 % of the nominal tube outside diameter. Greater thickness can be required due to pressure rating and material considerations.

**7.1.7.8** Threads of plugs having nominal diameters 30 mm ( $1\frac{1}{4}$  in.) and smaller shall be fine series threads.

### **7.1.8 Gaskets**

**7.1.8.1** Plug gaskets shall be of the solid-metal type. Plug gasket material shall be the same type as that of the plug, unless otherwise agreed to by the Purchaser and Vendor. Plug gasket hardness shall be less than that of the plug and the plug-sheet materials.

**7.1.8.2** Plug gaskets shall be flat and free of burrs.

**7.1.8.3** The minimum thickness of solid metal plug gaskets shall be 1.5 mm (0.060 in.).

**7.1.8.4** For the joint type shown in Figure 4 a), cover plate and bonnet gaskets shall be of the double-metal-jacketed, filled type or solid metal with a soft gasket seal facing. Filler material shall be non-asbestos and shall be suitable for sealing, exposure resistance and fire safety performance.

**7.1.8.5** For the joint type shown in Figure 4 b), double-metal-jacketed, filled type gaskets or [at design pressures of 2100 kPa gauge (300 psig) or less] compressed sheet composition gaskets suitable for the service shall be used. Gaskets shall be non-asbestos and shall be suitable for sealing, exposure resistance and fire safety performance.

**7.1.8.6** For the joint type shown in Figure 4 c), compressed sheet composition gaskets suitable for the service may be used at design pressures of 2100 kPa gauge (300 psig) or less. Gaskets shall be non-asbestos and shall be suitable for sealing, exposure resistance and fire safety performance.

**7.1.8.7** The width of removable cover plate and removable bonnet gaskets shall be at least 10 mm ( $\frac{3}{8}$  in.).

**7.1.8.8** Gaskets shall be of one piece. Where welds are used they shall meet the following.

- a) Welds in the perimeter portion of the gasket shall be continuous and full-penetration. The cross-section, finish and flatness of these welded areas shall match the remainder of the perimeter gasket.
- b) Welds shall not inhibit the sealing or compression of the perimeter gasket or pass ribs.

**7.1.8.9** Tables in Annex A may be consulted for further guidance on gaskets.

### **7.1.9 Nozzles and Other Connections**

**7.1.9.1** Flanges shall be in accordance with the pressure design code unless otherwise specified by Purchaser.

**7.1.9.2** Connections of nominal size DN 32 (NPS  $1\frac{1}{4}$ ), DN 65 (NPS  $2\frac{1}{2}$ ), DN 90 (NPS  $3\frac{1}{2}$ ), DN 125 (NPS 5) or less than DN 20 (NPS  $\frac{3}{4}$ ) shall not be used.

**7.1.9.3** Connections DN 40 (NPS  $1\frac{1}{2}$ ) and larger shall be flanged.

**7.1.9.4** In hydrogen service, sour, or wet hydrogen sulfide service, all connections shall be flanged. Slip-on and lap joint flanges shall not be used.

**7.1.9.5** If design conditions require the equivalent of PN 150 (ASME Class 900) or higher flange ratings, all connections shall be flanged.

**7.1.9.6** The nominal thickness of the nozzle neck, of carbon steel and low-alloy steel flanged connections shall not be less than specified in Table 3.

**Table 3 — Minimum Nozzle Neck Nominal Thickness**

<b>Pipe Size</b> DN (NPS)	<b>Nozzle Neck Thickness</b> mm (in.)
20 ( <sup>3</sup> / <sub>4</sub> )	5.56 (0.219)
25 (1)	6.35 (0.250)
40 (1 <sup>1</sup> / <sub>2</sub> )	7.14 (0.281)
50 (2)	8.74 (0.344)
80 (3)	11.13 (0.438)
100 (4)	13.49 (0.531)
150 (6)	10.97 (0.432)
200 (8)	12.70 (0.500)
250 (10)	15.09 (0.594)
300 (12)	17.48 (0.688)

NOTE The data in this table are taken from ASME B36.10M, using schedule 160 for sizes up to DN 100 (NPS 4) and schedule 80 for the larger sizes.

- **7.1.9.7** The facing of process flanges shall be in a horizontal plane unless another arrangement is specified by the Purchaser.

**7.1.9.8** Flanged connections shall be one of the following types:

- a forged or centrifugally cast, integrally flanged welding neck;
- a pipe welded to a forged or centrifugally cast welding neck flange;
- a seamless transition piece attached to a forged or centrifugally cast welding neck flange;
- a fabricated transition (e.g. nozzle necks that are fabricated by rolling and welding of plate), if agreed by the Purchaser;
- a casting, if agreed by Purchaser;
- a lap joint stub-in (except for carbon steel and low-alloy), if agreed by Purchaser.

**7.1.9.9** If a transition is used, stay bars, greater header thickness or greater nozzle thickness can be required to provide adequate mechanical strength.

**7.1.9.10** Threaded connections shall be not less than DN 25 (NPS 1), except that pressure gauge connections shall be not less than DN 20 (NPS <sup>3</sup>/<sub>4</sub>). This includes auxiliary connections such as vents, drains, instrument connections, and chemical cleaning connections.

**7.1.9.11** Threaded connections shall be one of the following types and shall comply with the pressure design code:

- a) forged steel full-coupling threaded one end only, with a suitable rating (e.g. ASME B16.11, class 6000);
- b) forged steel fitting with integral reinforcement;
- c) tapped holes for vent and drain connections, where header plate thickness permits;
- d) equivalent boss connection.

**7.1.9.12** If a thermowell connection is specified, it shall be located in the nozzle unless the nozzle is smaller than DN 100 (NPS 4), in which case the connection shall be located on the header adjacent to the nozzle.

**7.1.9.13** If a pressure gauge connection is specified, it shall be located on the nozzle unless the nozzle is smaller than DN 80 (NPS 3), in which case the connection shall be located on the header adjacent to the nozzle.

**7.1.9.14** Pipe threads shall be taper pipe threads (e.g. ASME B1.20.1) and shall comply with the pressure design code.

- **7.1.9.15** The size, type, and location of chemical cleaning connections, if any, shall be specified by the Purchaser.

**7.1.9.16** If specified, instrument connections shall be located in at least one inlet and outlet nozzle per bundle, except that none is required in intermediate nozzles of stacked bundles.

**7.1.9.17** All threaded pipe connections shall be closed with round-headed solid plugs.

**7.1.9.18** Flanged auxiliary connections, if any, shall be closed with blind flanges. Gaskets and bolting materials shall be suitable for the specified operating conditions.

**7.1.9.19** Vent and drain connections shall be provided at high and low points, respectively, on each header. Header nozzles installed at high and low points may serve as vents and drains. Connections serving as vents and drains shall not extend into the header beyond the inside surface.

**7.1.9.20** If the header thickness does not permit minimum thread engagement of vent and drain plugs, couplings or built-up bosses shall be installed.

**7.1.9.21** Bolts between connecting nozzles of stacked tube bundles shall be removable without moving the bundles.

## **7.1.10 Maximum Allowable Moments and Forces for Nozzles and Headers**

**7.1.10.1** Each nozzle, in its design corroded condition, shall be capable of withstanding the simultaneous application of the moments and forces defined in Figure 6 and Table 4.

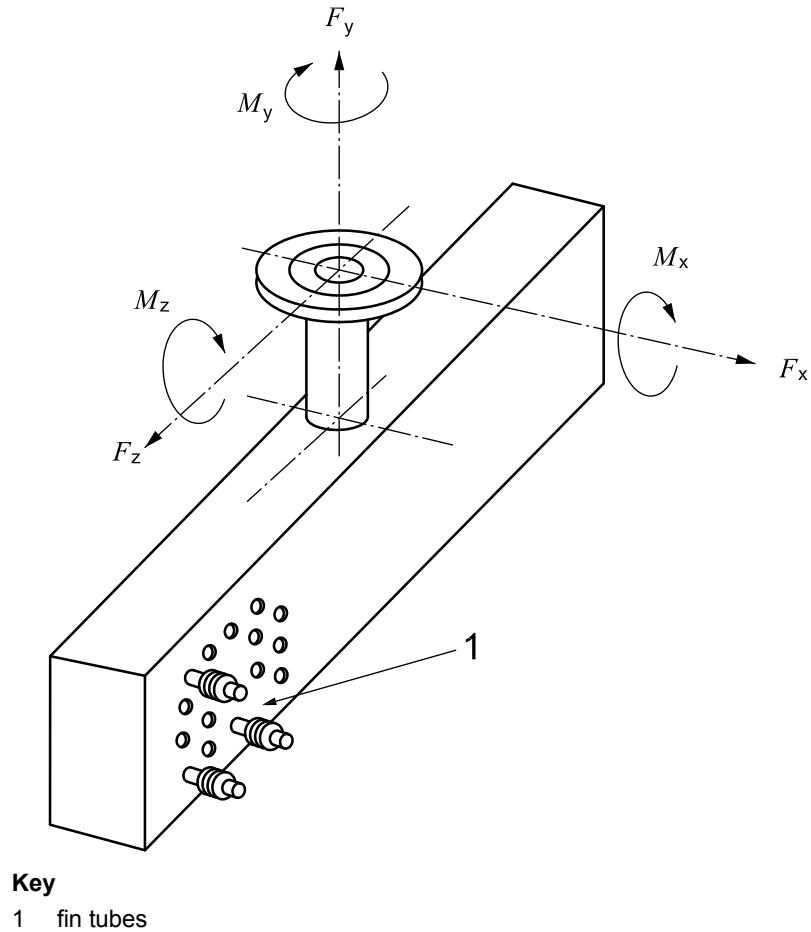

Figure 6 — Nozzle Loads

Table 4 — Maximum Allowable Nozzle Loads

Nozzle Size DN (NPS)	Moments N·m (ft·lbf)			Forces N (lbf)		
	$M_x$	$M_y$	$M_z$	$F_x$	$F_y$	$F_z$
40 (1½)	110 (80)	150 (110)	110 (80)	670 (150)	1020 (230)	670 (150)
50 (2)	150 (110)	240 (180)	150 (110)	1020 (230)	1330 (300)	1020 (230)
80 (3)	410 (300)	610 (450)	410 (300)	2000 (450)	1690 (380)	2000 (450)
100 (4)	810 (600)	1220 (900)	810 (600)	3340 (750)	2670 (600)	3340 (750)
150 (6)	2140 (1580)	3050 (2250)	1630 (1200)	4000 (900)	5030 (1130)	5030 (1130)
200 (8)	3050 (2250)	6100 (4500)	2240 (1650)	5690 (1280)	13,340 (3000)	8010 (1800)
250 (10)	4070 (3000)	6100 (4500)	2550 (1880)	6670 (1500)	13,340 (3000)	10,010 (2250)
300 (12)	5080 (3750)	6100 (4500)	3050 (2250)	8360 (1880)	13,340 (3000)	13,340 (3000)
350 (14)	6100 (4500)	7120 (5250)	3570 (2630)	10,010 (2250)	16,680 (3750)	16,680 (3750)

**7.1.10.2** The design of each fixed or floating header, the design of the connections of fixed headers to side frames, and the design of other support members shall ensure that the simultaneous application (sum) of all nozzle loadings on a single header does not cause any damage. The components of the nozzle loadings on a single header shall not exceed the following values:

$M_x$	6100 N·m (4500 ft·lbf)
$M_y$	8130 N·m (6000 ft·lbf)
$M_z$	4070 N·m (3000 ft·lbf)
$F_x$	10,010 N (2250 lbf)
$F_y$	20,020 (4500 lbf)
$F_z$	16,680 (3750 lbf)

NOTE The application of the moments and forces shown in Table 4 will cause movement that will tend to reduce the loads to the values given above.

**7.1.10.3** The total of all nozzle loads on one multi-bundle bay shall not exceed three times that allowed for a single header.

**7.1.10.4** See 7.1.6.1.3 for further details.

**7.1.11 Tubes**

**7.1.11.1** The outside diameter of cylindrical tubes should be at least 25.4 mm (1 in.).

- **7.1.11.2** The maximum tube length shall be as specified by the Purchaser.

**7.1.11.3** The wall thickness for tubes with an outside diameter of 25.4 mm (1 in.) to 51 mm (2 in.) shall not be less than that specified in Table 5.

**Table 5 — Minimum Required Wall Thickness of Tubes**

Tube Material	Minimum Required Wall Thickness <sup>a</sup> mm (in.)
Carbon steel or ferritic low-alloy steel (max. 9 % chromium)	2.11 (0.083)
High-alloy [austenitic, ferritic and austenitic/ferritic (duplex)] steel	1.65 (0.065)
Non-ferrous material	1.65 (0.065)
Titanium	1.24 (0.049)
<sup>a</sup> For embedded fin tubes, this thickness shall be measured from the bottom of the groove to the inner wall.	

**7.1.11.4** Tubes shall be furnished on either a minimum wall basis or an average wall basis, provided the wall thickness is nowhere less than that specified in 7.1.11.3.

**7.1.11.5** Tubes may be finned or unfinned.

**7.1.11.6** For finned tubes, the total unfinned length between tubesheets after assembly shall not exceed 1.5 times the thickness of one tubesheet.

- **7.1.11.7** Finned tube construction shall be agreed to by the Purchaser and the Vendor. The Vendor shall demonstrate that the type of construction furnished is suitable for the intended service conditions (taking into account factors such as metal temperature, cycling, loss of cooling, effect of environment and any specified abnormal operating conditions). The following are descriptions of several types of commonly used finned tube construction.
  - a) Embedded — rectangular cross-section aluminum fin wrapped under tension and mechanically embedded in a groove  $0.25 \text{ mm} \pm 0.05 \text{ mm}$  ( $0.010 \text{ in.} \pm 0.002 \text{ in.}$ ) deep, spirally cut into the outside surface of a tube. Tube wall thickness is measured from the bottom of the groove to the inside diameter of the tube. The fin end at each end of the tube shall be secured to prevent loosening or unraveling of the fins; the Vendor shall indicate the method used.
  - b) Extruded (integral) — an aluminum outer tube from which fins have been formed by extrusion, mechanically bonded to an inner tube or liner.
  - c) Overlapped footed — L-shaped aluminum fin wrapped under tension over the outside surface of a tube, with the tube fully covered by the overlapped feet under and between the fins. The fin end at each end of the tube shall be secured to prevent loosening or unraveling of the fins; the Vendor shall indicate the method used.
  - d) Footed — L-shaped aluminum fin wrapped under tension over the outside surface of a tube, with the tube fully covered by the feet between the fins. The fin end at each end of the tube shall be secured to prevent loosening or unraveling of the fins; the Vendor shall indicate the method used.
  - e) Externally bonded — tubes on which fins are bonded to the outside surface by hot-dip galvanizing, brazing, or welding.
  - f) Knurled footed — L-shaped aluminum fin wrapped under tension over the outside surface of a tube, while the foot of the fin is simultaneously pressed into the ribbed outer surface of the tube. The fin end at each end of the tube shall be secured to prevent loosening or unraveling of the fins; the Vendor shall indicate the method used.

**7.1.11.8** For fins wrapped under tension or embedded, the minimum stock thickness shall be as follows:

- for fin heights less than  $12.7 \text{ mm}$  ( $1/2 \text{ in.}$ ), the minimum stock thickness shall be  $0.35 \text{ mm}$  ( $0.014 \text{ in.}$ );
- for fin heights equal to and above  $12.7 \text{ mm}$  ( $1/2 \text{ in.}$ ), the minimum stock thickness shall be  $0.40 \text{ mm}$  ( $0.016 \text{ in.}$ ).

**7.1.11.9** Flattening in the bend of U-tubes shall not exceed 10 % of the nominal outside diameter of the tube.

**7.1.11.10** The minimum tube wall thickness at the U-bend shall be calculated in accordance with Equation (1).

$$t_b = \frac{t}{\left[ 1 + \frac{D_o}{4R_m} \right]} \quad (1)$$

where

$t_b$  is the minimum tube wall thickness after bending;

$t$  is the tube wall thickness before bending;

$D_o$  is the tube outside diameter;

$R_m$  is the mean radius of U-bend.

The calculated thickness,  $t_b$ , shall not be less than the minimum required tube wall thickness specified in 7.1.11.3.

**7.1.11.11** If U-bends are formed from tube materials that are relatively non-work-hardening and are of suitable temper, tube-wall thinning in the bends shall not exceed 17 % of the original tube wall thickness.

- **7.1.11.12** Requirements for heat treatment after bending of the U-tubes shall be specified by the Purchaser. The procedures and extent of heat treatment shall be in accordance with the pressure design code and shall be agreed to between Purchaser and Vendor.

**7.1.11.13** Elliptical tubes shall not be used unless agreed to by the Purchaser. See A.3.3.5 to A.3.3.7.

## 7.2 Air-side Design

### 7.2.1 General

- **7.2.1.1** Factors such as weather, terrain, mounting, environment and the presence of adjacent structures, buildings and equipment influence the air-side performance of an air-cooled heat exchanger. The Purchaser shall supply the Vendor with all such environmental data pertinent to the design of the exchanger. These factors shall be taken into account in the air-side design.

**7.2.1.2** All air-cooled heat exchangers, whether they are located in a single stand-alone orientation or in a bank of several bays located side by side, require adequate clearance below the fan plenum for forced draft units, or below the tube bundle for induced draft units, to allow an adequate quantity of air to enter the bay and traverse the tube bundle. The velocity of the air approaching the air-cooled heat exchanger (approach velocity) shall not exceed a nominal value of 3.6 m/s (700 ft/min) for forced draft units, or 4 m/s (800 ft/min) for induced draft units at the perimeter of the bay and/or bank. Adjusting the column height is the normal way that the approach velocity is attained on grade-mounted installations. Consideration shall also be given to providing adequate head clearances for mechanical equipment maintenance when adjusting the column heights. See A.3.10.

**7.2.1.3** The minimum height above grade for grade-mounted installations shall be calculated in accordance with Equation (2):

$$h = \frac{q_v}{l_p \times k} \tag{2}$$

where

$h$  is the height above grade to the bottom of the plenum chamber for forced draft type units, or to the bottom of the tube bundle side frames for induced draft type units, expressed in meters (feet);

$q_v$  is the total actual volumetric flow rate of air that the air-cooled heat exchanger(s) are designed to use at design conditions, expressed in actual cubic meters per second (actual cubic feet per minute);

$l_p$  is the length of the perimeter of the bay or bank, expressed in meters (feet), from which air will be free flowing into the air-cooled heat exchanger(s). [Include only the perimeter of which no air is

being blocked or hindered by other structures or bays from entering the air-cooled heat exchanger(s)];

- $k$  is a constant, which is 3.6 m/sec (700 ft/min) for forced draft units and 4.1 m/sec (800 ft/min) for induced draft units.

**7.2.1.4** For forced draft units, the kinetic energy of the entering air (ambient air density multiplied by the square of the air approach velocity) shall be less than that of the discharge air exiting the tube bundle (exit air density multiplied by the square of the nominal air discharge velocity).

**7.2.1.5** For units with air inlet louvers at the perimeter, the louver area (inside the louver frames) shall be used to determine the approach velocity. Where screens are provided at the perimeter, the area used to calculate the approach velocity shall be discounted by accounting for the area blocked by the screen mesh.

**7.2.1.6** The requirement for air flow control shall be as defined by the Purchaser on the basis of specific process operation requirements, including the effect of weather.

**7.2.1.7** Fan selection at design conditions shall ensure that at rated speed the fan can provide, by an increase in blade angle, a 10 % increase in air flow with a corresponding pressure increase. Since this requirement is to prevent stall and inefficient operation of the fan, it is not necessary that the resulting increased power requirement govern the driver rating.

- **7.2.1.8** If requested by the Purchaser, the Vendor shall estimate the design exposure temperatures for mechanical components using conventional heat transfer analyses and shall submit the estimate to the Purchaser for approval.

For items using air recirculation systems, design exposure temperatures for each operating mode (start-up, normal operation, shutdown, loss of power, stagnated air flow, one fan inoperable, etc.) shall be examined.

## 7.2.2 Noise Control

- **7.2.2.1** For a heat exchanger operating in the specified service with fans operating at design speed and pitch, either or both of the following noise limits shall be specified by the Purchaser:
  - a) sound-pressure level ( $L_p$ ) values per fan at the location designated by the Purchaser;
  - b) sound-power level ( $L_W$ ) values per fan.

NOTE A typical noise data sheet is shown in Annex B.

The Vendor shall submit sound-power and sound-pressure levels of the equipment, taking into account relevant information, e.g. inlet shape (type and dimension of bell or cone), obstructions, etc. Reference to fan includes driver, speed reducer, etc.

**7.2.2.2** The order of preference for obtaining the required noise data shall be as follows:

- a) actual testing of a representative bay installed either in an environment remote from other noise sources (shop or field tests) or installed in an operating plant;
- b) derivation of noise data by testing similar equipment and adjusting the data for the actual equipment size and operating conditions. Both the measured data and the correction procedure shall be reported.

**7.2.2.3** Guidance for determining noise levels is included in Annex E.

**7.2.3 Fans and Fan Hubs**

**7.2.3.1** Two or more fans aligned in the direction of tube length shall be provided for each bay, except that single-fan arrangements may be used if agreed by the Purchaser.

**7.2.3.2** Fans shall be of the axial flow type.

**7.2.3.3** Each fan shall be sized such that the area occupied by the fan is at least 40 % of the bundle face area served by that fan (the bundle face area being the nominal width of the bundle or bundles multiplied by the nominal tube length).

**7.2.3.4** Each fan shall be located such that its dispersion angle shall not exceed 45 degrees at the bundle centerline, as shown in Figure 7.

**7.2.3.5** The fan tip speed shall not exceed the maximum value specified by the fan manufacturer for the selected fan type. Fan tip speed shall not exceed 60 m/s (12,000 ft/min) unless approved by the Purchaser. In no case shall the fan tip speed exceed 80 m/s (16,000 ft/min). Noise limitations can require lower speeds.

**7.2.3.6** The radial clearance between the fan tip and the fan orifice ring shall be as shown in Table 6.

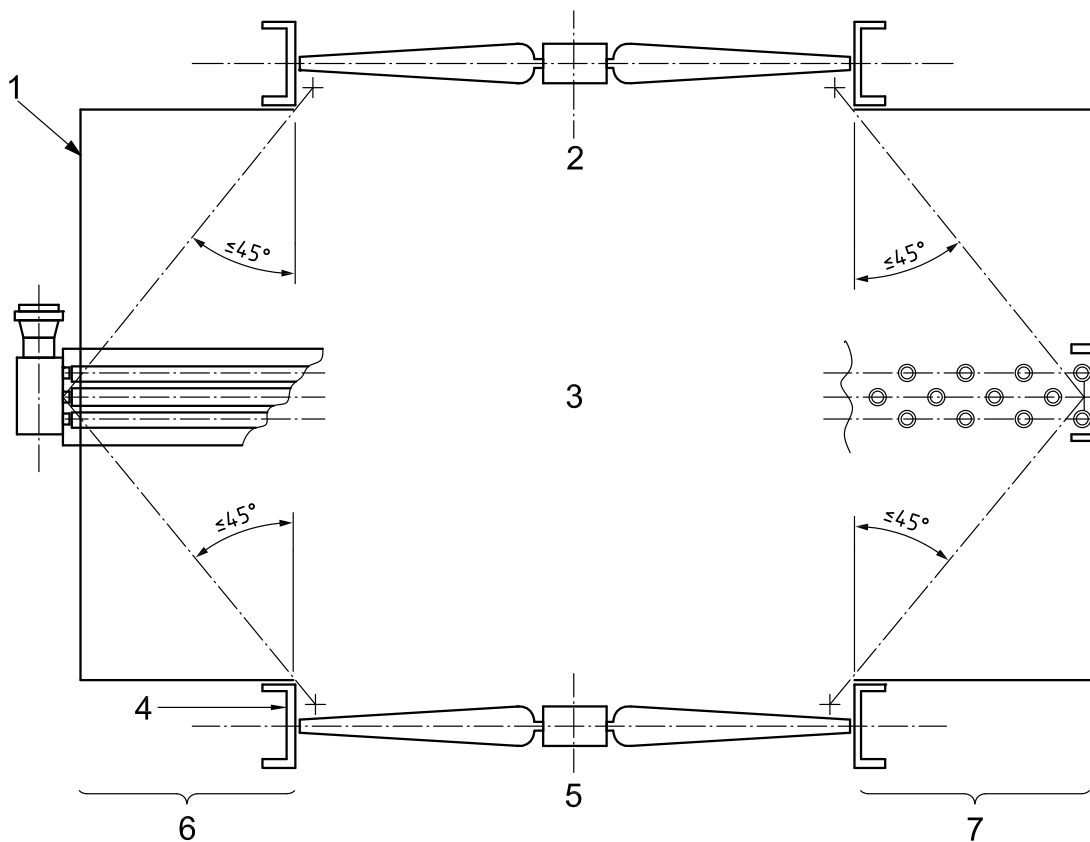

**Key**

1	plenum	5	forced draught
2	induced draught	6	side
3	centerline of bundle	7	front
4	fan ring		

**Figure 7 — Fan Dispersion Angle**

**Table 6 — Radial Clearances**

Fan Diameter		Radial Clearance	
		mm (in.)	
m	(ft)	Minimum	Maximum
≤ 3.0	(≤ 9)	6.35 ( <sup>1</sup> / <sub>4</sub> )	12.7 ( <sup>1</sup> / <sub>2</sub> )
> 3.0 and ≤ 3.5	(> 9 and ≤ 11)	6.35 ( <sup>1</sup> / <sub>4</sub> )	15.9 ( <sup>5</sup> / <sub>8</sub> )
> 3.5	(> 11)	6.35 ( <sup>1</sup> / <sub>4</sub> )	19.05 ( <sup>3</sup> / <sub>4</sub> )

**7.2.3.7** Detachable fan blades shall be moment-balanced against a master blade.

**7.2.3.8** Each fan assembly shall be balanced by one of the following means:

- a) dynamic balancing as an assembly;
- b) dynamic balancing of the hub and static moment-balancing of the blades.

**7.2.3.9** The fan assembly shall be designed to minimize reverse air flow at the hub.

- **7.2.3.10** For fans having a diameter larger than 1.5 m (5 ft), individual fan blades shall be manually adjustable for varying blade pitch. The use of automatic control for varying the blade pitch shall be as specified by the Purchaser.

**7.2.3.11** Fans equipped for pneumatically actuated, automatically controlled pitch adjustment of blades shall comply with the following.

- a) If a single controller operates more than one actuator, the Purchaser shall provide an isolating valve in the control signal line for each actuator, to allow maintenance.
  - b) The pneumatic actuator may be equipped with a positioner or a bias relay.
  - c) If provided, the positioner or bias relay shall be designed to operate on a 20 kPa to 100 kPa gauge (3 psig to 15 psig) pneumatic control signal. Each change in the control signal shall result in a corresponding change in the fan blade pitch. The operating range of the positioner shall be adjusted so that the maximum pitch obtained is equal to the selected design blade angle setting. The fan manufacturer shall set maximum and minimum blade pitch limit stops. Unless otherwise specified by the Purchaser, the minimum blade pitch limit shall result in an essentially zero air flow.
  - d) The Vendor shall furnish a flexible tubing connection approximately 300 mm (12 in.) long for connecting to the Purchaser's control-air line. The tubing shall connect to a rigid steel or alloy pipe or tube that terminates outside the fan enclosure. A terminal fitting for connection to the Purchaser's control-air line shall be DN 8 (NPS <sup>1</sup>/<sub>4</sub>). Pipe threads shall be taper pipe threads.
- e) The Purchaser shall specify the direction of change of the fan pitch with loss of control-air pressure.

**7.2.3.12** Hub and fan assemblies with automatically controllable pitch adjustment employing lubricated joints shall be designed to minimize lubrication maintenance through the use of bearings not requiring periodic re-lubrication.

**7.2.3.13** The fan characteristic performance curve shall relate static or total pressure, rate of flow, blade pitch, and fan input shaft power, for dry-air standard conditions as stated in Table 7. The operating point and power for the specified design conditions shall be shown on the fan characteristic performance curve.

**Table 7 — Dry-air Standard Conditions**

Dry-bulb temperature	21.1 °C (70 °F)
Pressure	101.3 kPa (29.92 in. of mercury)
Density	1.2 kg/m <sup>3</sup> (0.075 lb/ft <sup>3</sup> )

**7.2.3.14** The natural frequency of the fan or fan components shall not be within 10 % of the blade-pass frequency. Blade-pass frequency (in passes per second) equals the number of blades multiplied by the fan speed (in revolutions per second). Slipping drive belts, low power supply voltage or variable fan-speed control operation cause fan speeds lower than design values; if the blade pass frequency exceeds the natural frequency of the fan or component, the effect of such operation shall be evaluated.

**7.2.3.15** No materials (fan blades, hubs, blade retainers and any elastomeric material, etc.) shall be exposed to temperatures above the manufacturer's recommended operating limit, regardless of whether the fan is at rest or in operation.

**7.2.3.16** The fan design for the exchanger shall take into account the additional pressure drop associated with the air flowing across insect and lint screens, plus an additional allowance for fouling that takes place on the screens. The estimated additional fouling pressure drop shall be equal to two (2) times the clean pressure drop through the screens. The pressure drop from air flowing across hail screens shall also be taken into account, although it is not necessary to add an additional fouling pressure drop due to the location of the hail screens.

#### **7.2.4 Fan Shafts and Bearings**

**7.2.4.1** Anti-friction shaft bearings shall have a calculated rating life,  $L_{10}$ , of 50,000 h at maximum load and speed in accordance with ISO 281 and/or ISO 76, where  $L_{10}$  is the number of hours at rated bearing load and speed that 90 % of a group of identical bearings will complete or exceed before the first evidence of failure.

**7.2.4.2** The bearing design shall incorporate seals to prevent lubricant loss and entry of foreign materials.

**7.2.4.3** The fan shaft shall be properly sized for the bearings. Bearings shall be sized in accordance with ISO 281 and/or ISO 76.

**7.2.4.4** Fan shaft stresses shall not exceed the values given in AGMA 6001.

**7.2.4.5** Fan shafts shall have key seats and fits in accordance with ISO 2491 and ISO 286 (all parts) (tolerance N8).

**7.2.4.6** Fan bearing exposure temperatures above 127 °C (260 °F) require one or more special features such as high-temperature seals, heat stabilization, retainers or modified internal clearances. Lubricants shall be suitable for the design exposure temperature plus any temperature due to friction and loading.

#### **7.2.5 Lubrication Facilities**

Connections shall be provided outside the fan guards to permit grease lubrication of fan shaft bearings without shutdown of the equipment. Stainless steel tubing with an outside diameter of at least 6 mm ( $\frac{1}{4}$  in.) shall be used for grease lines. The connections shall be accessible from grade or service platforms. The length of the grease lines should be minimized.

## 7.2.6 Fan Guards

- 7.2.6.1** Removable steel fan guards shall be furnished on forced-draught exchangers.
- 7.2.6.2** Fan blade and fan guard materials shall be a non-sparking combination.
- 7.2.6.3** Flattened expanded metal for fan guards shall not exceed 50 mm (2 in.) nominal mesh size.
- 7.2.6.4** The minimum thickness of expanded metal mesh shall be as shown in Table 8.

**Table 8 — Minimum Thickness of Expanded Metal Fan Guard Mesh**

Nominal size mm (in.)	Minimum thickness mm (in.)
40 (1½)	2 (0.070)
50 (2)	3 (0.110)

**7.2.6.5** The openings in woven or welded mesh for fan guards shall not exceed an average area of 2600 mm<sup>2</sup> (4 in.<sup>2</sup>) if the wire spacing in both directions exceeds 25 mm (1 in.).

**7.2.6.6** The thickness of wire for welded or woven mesh shall be at least 2.77 mm (12 BWG; 0.109 in.).

NOTE BWG is Birmingham Wire Gauge.

**7.2.6.7** Fan guards shall be designed with stiffening members so that a concentrated load of 1000 N (225 lbf) on any 0.1 m<sup>2</sup> (1 ft<sup>2</sup>) shall not cause fastener failure or stiffener deflection greater than  $L/90$ , where  $L$  is the length of the span between points of support.

**7.2.6.8** The distance from the fan guard to the fan blade at its maximum operating pitch shall be at least 150 mm (6 in.) or six times the smaller of the opening dimensions, whichever is less.

**7.2.6.9** Gaps between the fan guard and equipment or between sections of the fan guard shall not exceed 12 mm (½ in.).

## 7.2.7 Drivers

### 7.2.7.1 General

- **7.2.7.1.1** The Purchaser shall specify the type of drive system and the Vendor's scope of supply.

**7.2.7.1.2** For electric motor drivers, the minimum required driver rated shaft power ( $P_{dr}$ ) shall be calculated as follows:

$$P_{dr} \geq 1.05 (P_{f1}/E_m)$$

$$P_{dr} \geq 1.10 (P_{f2})$$

where

$P_{dr}$  is driver rated shaft power;

- $P_{f1}$  is fan shaft power operating at specified minimum design temperature with blade angle set for design dry-bulb temperature;
- $E_m$  is mechanical efficiency of the power transmissions;
- $P_{f2}$  is fan shaft power operating at design dry-bulb temperature.

These requirements apply to fixed-pitch, variable-pitch and variable-speed fans unless otherwise specified.

### 7.2.7.2 Electric Motor Drivers

- **7.2.7.2.1** Electric motors shall be three-phase, totally enclosed, fan-cooled motors suitable for service in petrochemical installations and capable of full-voltage starting, full-phase inversion, continuous duty and designed for an 80 °C (140 °F) temperature rise over 40 °C (104 °F) ambient temperature at nameplate rating. The Purchaser shall specify the voltage and frequency, the applicable motor specification, the hazardous area classification, the temperature classification and the insulation class.

**7.2.7.2.2** The motor manufacturer shall be advised that the motor is intended for air-cooled heat exchanger service and operation outdoors, unprotected against the weather. If the motor operates vertically, the motor manufacturer shall verify in writing that the motor is suitable for vertical operation, either shaft up or shaft down.

**7.2.7.2.3** Unless otherwise agreed by the Purchaser, motor frames shall be of cast steel or corrosion-resistant cast iron, with integrally cast support feet.

**7.2.7.2.4** The motor design loading shall exclude the service factor allowance.

**7.2.7.2.5** Motors shall have grease-lubricated bearings designed for a  $L_{10}$  life of at least 40,000 h under continuous duty at rated load and speed (see 7.2.4.1 for the definition of  $L_{10}$ ). If the motor is mounted vertically, the bearing lubrication system and seals shall be suitable for a vertically mounted motor.

**7.2.7.2.6** If the motor is mounted in the shaft-up position, the belt sheave shall be designed as a shield to prevent water from accumulating and being directed down the motor shaft while the motor is either idle or running. Alternatively, an external conical slinger may be fitted to the shaft to prevent water from entering the housing along the shaft.

**7.2.7.2.7** Motors shall have drains at the lowest point of the frame as mounted on the air-cooled heat exchanger.

**7.2.7.2.8** Standard motors are designed for 40 °C (104 °F) ambient temperature and altitudes not exceeding 1000 m (3280 ft). Higher temperatures and/or altitudes (resulting in reduced air density) can require improved insulation or an increase in motor frame size. If it is required that the motor be suitable for service exceeding the standard conditions, the motor manufacturer shall be notified.

- **7.2.7.2.9** If specified by the Purchaser, a self-actuating braking device shall be installed to prevent reverse rotation of an idle fan.

### 7.2.7.3 Variable-speed Drive Systems

- Requirements for variable-speed drive systems (VSDS) shall be agreed between the Purchaser and the Vendor. This shall include the range of speeds required.

## 7.2.8 Couplings and Power Transmissions

### 7.2.8.1 General

7.2.8.1.1 Bushings and couplings shall be either split taper or cylindrical fit and shall be keyed.

7.2.8.1.2 Power transmission components shall have a rated power for continuous service that is at least equal to the rated power of the actual driver multiplied by the component service factor.

7.2.8.1.3 Fan shaft and gear shaft couplings shall be the non-lubricated type and shall have a minimum service factor of 1.5.

7.2.8.1.4 Exposed moving parts shall have guards in accordance with 7.2.8.4.

7.2.8.1.5 Figure 8 shows typical drive arrangements.

### 7.2.8.2 Belt Drives

7.2.8.2.1 Belt drives shall be either conventional V-belts or high-torque type positive-drive belts.

7.2.8.2.2 Belt drives in a heated air stream (such as top-mounted drives) shall not be used unless approved by the Purchaser. If so approved, the belt design temperature shall take into account the maximum air temperature near the belt (or the maximum belt temperature possible due to radiation) under all conditions; decreased fan efficiency shall also be taken into account. The Vendor shall indicate how the driver is suspended; the driver should not be located in the heated air stream (see also 7.2.7.2.8 and 7.2.8.2.13).

7.2.8.2.3 Belt drives shall be provided with guards in accordance with 7.2.8.4.

7.2.8.2.4 Belt drives shall be provided with jack screws or an equivalent means of initial belt-tensioning and/or re-tensioning.

7.2.8.2.5 V-belt drives shall be in accordance with ISO 1081, ISO 4183, ISO 4184, ISO 5287, ISO 5290, and/or ISO 9563, as applicable.

7.2.8.2.6 V-belts shall be either matched sets of individual belts or a multiple-belt section formed by joining a matched set of individual belts.

7.2.8.2.7 High-torque type positive-drive belts may be either one belt or a pair of matched belts.

7.2.8.2.8 V-belts shall have a minimum service factor of 1.4 based on driver rated power.

7.2.8.2.9 High-torque type positive-drive belts shall have a minimum service factor of 1.8 based on driver-rated power.

7.2.8.2.10 V-belt drive assemblies suspended from the structure may be used with motor drivers rated not higher than 30 kW (40 hp).

7.2.8.2.11 High-torque type positive-drive-belt drive assemblies suspended from the structure may be used with motor drivers rated not higher than 45 kW (60 hp).

7.2.8.2.12 The drive-belt jacket shall be oil resistant.

7.2.8.2.13 Standard drive-belt materials are limited to an exposure temperature of 60 °C (140 °F).

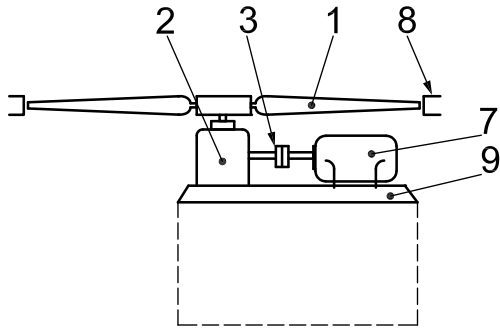

a) Direct right-angle gear drive

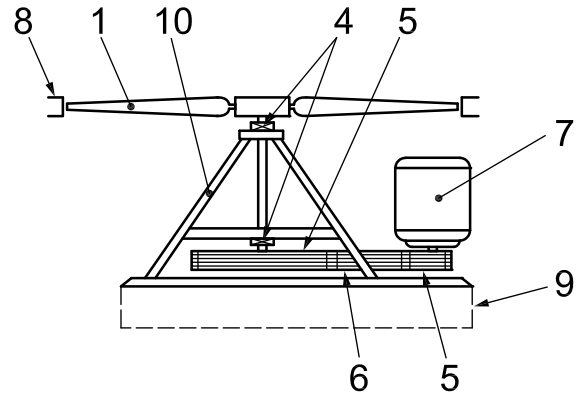

b) Belt drive

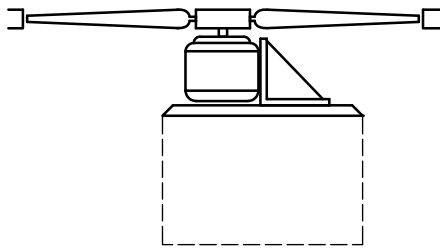

c) Direct motor drive

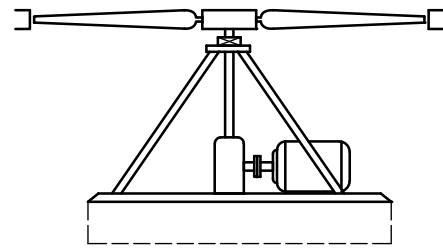

d) Right-angle gear drive with fan support

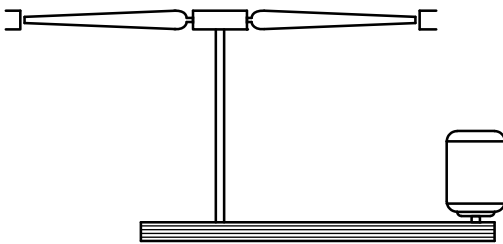

e) Suspended belt drive, motor shaft down

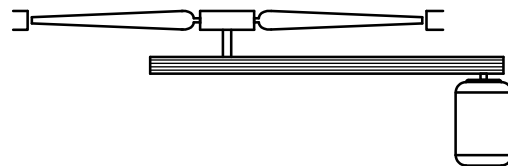

f) Suspended belt drive, motor shaft up

**Key**

- |            |                |
|------------|----------------|
| 1 fan      | 6 belt drive   |
| 2 gear box | 7 motor        |
| 3 coupling | 8 fan ring     |
| 4 bearing  | 9 base plate   |
| 5 sheave   | 10 fan support |

**Figure 8 — Typical Drive Arrangements**

### 7.2.8.3 Gear Drives

**7.2.8.3.1** Electric motors rated higher than 45 kW (60 hp) shall use gear drives; smaller motors may use gear drives.

**7.2.8.3.2** Gear drives for electric motors rated not higher than 45 kW (60 hp) may be suspended from the structure.

**7.2.8.3.3** Gears shall be of the spiral bevel type. They shall have a minimum service factor of 2.0 in accordance with ANSI/AGMA 6010.

**7.2.8.3.4** Top-mounted gear drives shall not be used.

**7.2.8.3.5** Gear boxes shall be provided with an external oil level indicator visible from the maintenance platform.

### 7.2.8.4 Mechanical Power Transmission Guards

**7.2.8.4.1** Guards shall be provided for moving components.

**7.2.8.4.2** Guards shall be constructed to allow ready access for maintenance of the equipment.

**7.2.8.4.3** Gaps between guards and equipment shall not exceed 12 mm ( $1/2$  in.).

### 7.2.9 Vibration Cut-out Switches

- **7.2.9.1** One readily accessible, double-throw, two-contact, vibration cut-out switch shall be provided for each fan driver unit if specified by the Purchaser.

**7.2.9.2** Vibration cut-out switches shall be of the manual, externally reset type, not requiring dismantling of the switch for resetting and shall have sensitivity adjustment.

### 7.2.10 Louvers

**7.2.10.1** All requirements in 7.2.10 apply to both parallel- and opposed-action louvers, unless otherwise specified.

**7.2.10.2** The thickness of louver blades manufactured from plain sheets shall be at least 1.5 mm (16 gauge USS; 0.060 in.) for carbon steel and 2.3 mm (13 gauge USS; 0.090 in.) for aluminum. The thickness of extruded hollow-shaped aluminum blades shall be at least 1.5 mm (16 gauge USS; 0.060 in.).

**7.2.10.3** Frames of carbon steel shall be at least 3.5 mm (10 gauge USS; 0.135 in.) thick; frames of aluminum shall be at least 4 mm (0.160 in.) thick.

**7.2.10.4** The unsupported louver blade length shall not exceed 2.1 m (7 ft).

**7.2.10.5** The deflections of louver blades and side frames shall not exceed the values given in Table 9.

**7.2.10.6** The deflection of louver blades and side frames shall be evaluated at a metal temperature equal to the higher of the following:

- a) maximum process inlet temperature, less 30 °C (50 °F);
- b) specified air inlet dry-bulb temperature.

**Table 9 — Maximum Allowable Louver Deflection**

Louver Components	Maximum Deflection
Louver blades in closed position with design load of 2000 N/m <sup>2</sup> (40 lb/ft <sup>2</sup> )	<i>L</i> /180
Louver side frames with uniform design load of 1000 N/m <sup>2</sup> (20 lb/ft <sup>2</sup> )	<i>L</i> /360
<i>L</i> designates the length of the span between points of support.	

**7.2.10.7** The gap between the louver blade and the frame at the header ends shall not exceed 6 mm (<sup>1</sup>/<sub>4</sub> in.).

**7.2.10.8** The gap between the louver blades and the frame at the louver sides shall not exceed 3 mm (<sup>1</sup>/<sub>8</sub> in.).

**7.2.10.9** Louver blade pivot pins shall be designed for their load but, in any case, shall be at least 10 mm (<sup>3</sup>/<sub>8</sub> in.) in diameter.

**7.2.10.10** Bearings shall be provided at all pivot points, including control arm, torque rod and blade pivot pins. Bearings shall not require lubrication. The exposure temperature shall not exceed 150 °C (300 °F) for polytetrafluoroethylene (PTFE) base composite bearing material in accordance with 8.4.2. Higher-temperature bearing materials are available but may be used only with the approval of the Purchaser.

**7.2.10.11** Louver linkages shall be designed so that equal movement of all louver blades results from a change of actuator position. The maximum allowable deviation shall be 3 mm (<sup>1</sup>/<sub>8</sub> in.), measured as a gap between any two blades with louver actuator in the fully closed position. The means of transmitting force between the louver actuator and the blades shall be adequate to withstand, without damage, the maximum possible force that can be applied by the actuator in any blade position and in either direction.

**7.2.10.12** Actuation of louver sections shall require a torque of not more than 7 N·m for each square meter (6 in.-lbf for each square foot) of face area to achieve full travel. The handling force to operate the louvers shall not exceed 250 N (56 lbf).

**7.2.10.13** The travel of louver blades from fully closed to fully open shall be at least 70 degrees.

**7.2.10.14** All shaft connections shall be attached at adjustable linkage points by keys, splines, or equivalent positive methods. Set-screw connections shall not be used.

**7.2.10.15** If used for automatic control, louver actuators shall be designed to operate with a 20 kPa to 100 kPa gauge (3 psig to 15 psig) pneumatic control signal. If supplied with design motive-air pressure, actuators shall be sized to supply at least 150 % of the necessary force for full-range louver blade travel. Design motive-air pressure shall be 410 kPa gauge (60 psig), unless otherwise specified.

**7.2.10.16** A positioner shall be provided at each actuator, unless otherwise specified.

**7.2.10.17** If a single controller operates more than one actuator, the Purchaser shall provide an isolating valve in the signal line for each actuator to allow maintenance.

**7.2.10.18** The location of the actuator and positioner assembly shall not interfere with access to the header, and both shall be readily accessible for maintenance from a service platform (if available). The assembly shall not be in the hot-air stream if the exit air temperature at any condition exceeds 70 °C (160 °F). Alternative materials shall be selected for higher exposure temperatures.

- **7.2.10.19** The louver position upon loss of control-air pressure shall be specified by the Purchaser.
  - 7.2.10.20** All louvers not automatically or otherwise remotely operated shall be provided with extensions or chains to permit manual operation from grade or platform, except that extensions or chains shall not be used if longer than 6 m (20 ft). Handles for manual operators shall not project into walkways or access ways in any operating position.
  - 7.2.10.21** A locking device shall be provided for manual operators to maintain louver position. Set-screw or thumb-screw locking devices shall not be used. A means shall be provided to indicate whether the louvers are open or closed.
  - 7.2.10.22** The louver characteristic performance curve shall relate the percentage of air flow to the angle of the louver blade.
  - 7.2.10.23** Due to the nature of their design, louvers are vulnerable to damage during handling. Spreader bars and anti-racking procedures should be used. Specific handling instructions shall be included on the louver assembly drawing and shall be marked on the louver at a lift point.
  - 7.2.10.24** Pin-type retainers shall be used to hold manual control levers of louvers in a set position; butterfly-type locking nuts shall not be used.
  - 7.2.10.25** All linkage joints shall be through-bolted or pinned; friction-type joints shall not be used. The bolting or pinning shall be done after final linkage adjustment.

## **7.2.11 Screens**

### **7.2.11.1 General**

- The Purchaser shall specify if screens are required and, if so, shall specify the type (hail screens, insect and/or lint screens).

### **7.2.11.2 Insect/lint Screens**

- 7.2.11.2.1** The Purchaser shall approve the screen location and design. In general, it is desirable to locate the screens for low air velocity at the exchanger periphery, normally located on the columns below the tube bundle or plenum chamber.
- 7.2.11.2.2** Screens shall be removable for cleaning, maintenance and off-season storage. They should be sized to facilitate ease of handling.
- 7.2.11.2.3** Screen mesh shall be wire cloth. The mesh size shall be number 8 for galvanized or number 16 for stainless steel. Other materials may be used if agreed with the Purchaser.

NOTE Mesh number is openings per linear inch, e.g. number 8 has 8 openings per linear inch which is 315 openings per meter.

### **7.2.11.3 Hail Screens**

- 7.2.11.3.1** In forced draft units, hail screens, if specified, shall be located directly above the tubes in the tube bundle and shall cover at least the finned portion of the tubes. In induced draft units, hail screens, if specified, shall be located above the fan in the fan ring.
- 7.2.11.3.2** Screens shall be either lightweight galvanized grating or galvanized wire cloth. The mesh size shall be number 8. The wire thickness shall be at least 0.43 mm (27 ASWG; 0.017 in.).

NOTE ASWG is American Standard Wire Gauge.

## 7.3 Structural Design

### 7.3.1 General

- **7.3.1.1** The structural code shall be specified or agreed by the Purchaser. Structural steel design, fabrication and erection shall be in accordance with the structural code.
- 7.3.1.2** Bolts for load-bearing members shall be designed and installed in accordance with the structural code.
- 7.3.1.3** Weld-metal design stress shall conform to the structural code.
- 7.3.1.4** Structural members shall be designed without the requirement for field welding.
- 7.3.1.5** For induced-draught exchangers, tube bundles shall be removable without removing the platforms, unless otherwise specified by the Purchaser. For forced-draught exchangers, the bundles shall be removable without separately supporting or dismantling the fan, plenum or platforms and without disturbing the structure or adjacent bays.
- 7.3.1.6** Suspended drives shall be attached to the structure by through-bolts to permit dismantling.

### 7.3.2 Vibration Testing

- 7.3.2.1** Structural members shall be designed to minimize vibration. The maximum amplitude of vibration over the design fan-speed range shall be 0.15 mm (0.006 in.) from peak to peak, as measured on primary structural members and machinery mountings.
- **7.3.2.2** The Purchaser shall specify if a shop test is required to verify compliance with the vibration limits.
- 7.3.2.3** Wind velocity at test conditions shall not exceed 5 m/s (10 mph).

### 7.3.3 Structural Design Loads and Forces

#### 7.3.3.1 General

The design shall take into account the loads and forces defined in 7.3.3.2 through 7.3.3.13.

#### 7.3.3.2 Dead Loads

- Dead loads shall consist of the total mass of the material furnished by the Vendor plus the mass of any fireproofing. If fireproofing is being applied, the Purchaser shall state the extent and type.

#### 7.3.3.3 Live Loads

Live loads shall consist of movable loads (including personnel, portable machinery, tools and equipment) and operating loads in equipment and piping. Design live loads on platforms, columns and walkways (exclusive of loads from piping and equipment in place) shall be as specified in Table 10.

#### 7.3.3.4 Impact Loads

The vertical design impact load for lifting devices furnished by the Vendor shall be two (2.0) times the mass of the heaviest piece of equipment being lifted. The lateral impact load shall be 0.35 times the mass being lifted.

**Table 10 — Live Loads on Platforms, Columns and Walkways**

Structural Component	Average Load	Concentrated Load
Floor plate or grating	4900 N/m <sup>2</sup> (100 lb/ft <sup>2</sup> )	—
Floor framing	2450 N/m <sup>2</sup> (50 lb/ft <sup>2</sup> )	2250 N (500 lb)
Columns and brackets	1200 N/m <sup>2</sup> (25 lb/ft <sup>2</sup> )	2250 N (500 lb)
Ladders and stairways	—	2500 N (500 lb)

### 7.3.3.5 Thermal Forces

Thermal forces shall include forces caused by partial or complete anchorage of piping or equipment, sliding or rolling friction of equipment and expansion or contraction of the structure. The Purchaser and the Vendor shall agree on acceptable thermal forces.

### 7.3.3.6 Test Load

The test load is that due to the additional mass of the water used for testing.

### 7.3.3.7 Wind Load

The wind design load shall be in accordance with the structural code.

### 7.3.3.8 Earthquake Forces

Earthquake design shall be in accordance with the ICC unless otherwise specified.

### 7.3.3.9 Nozzle Loads

Nozzle loads shall include all forces and moments applied to the nozzle face, such as deadweight of pipe, thermal forces, the mass of fluid in the piping, etc. The total magnitude and direction of these forces and moments shall be in accordance with 7.1.10 unless otherwise specified.

### 7.3.3.10 Fan Thrust

Fan thrust shall be based on the maximum thrust. If velocity pressure is not included, then fan thrust shall be based on the static pressure shown on the data sheet multiplied by 1.25.

### 7.3.3.11 Snow Load

- The Purchaser shall specify the snow load, if any, to apply to the total air-cooled heat exchanger plot area.

### 7.3.3.12 Other Loads

- Loads, forces and moments other than those described in 7.3.3.3 through 7.3.3.11 that are supported by, or applied to, the air-cooled heat exchanger shall be specified by the Purchaser in terms of exact type, location, magnitude and direction. Examples of such loads are special transportation loads, auxiliary pipe supports, ladders and walkways furnished by others, and temporary scaffolding supports. Structural and nozzle loads imposed by movement of the structure or installation (e.g. floating production system) on which the exchanger is mounted shall be specified by the Purchaser in terms of the exact type, location, magnitude, and direction (e.g. pitch, roll, yaw, heave, surge and sway).

### 7.3.3.13 Loading Combinations

All structural components shall be designed to support combinations of the loads and forces to which they can be subjected during erection, testing or flushing of the equipment or when operating at design conditions. The following combination of loads and forces shall be considered in the design of columns, bracing, anchor bolts and foundations and in checking stability against overturning:

a) erection:

- 1) dead load of the structure, less fireproofing;
- 2) the greater of the following:
  - i) dead load of equipment, less piping,
  - ii) dead load of equipment, less platforms supported by the equipment;
- 3) full wind load or earthquake load, whichever is greater;

b) testing or flushing equipment:

- 1) dead load of the structure, plus fireproofing;
- 2) dead load of equipment, including platforms supported by the equipment;
- 3) nozzle loads;
- 4) test loads;
- 5) wind load of 500 N/m<sup>2</sup> (10 lbf/ft<sup>2</sup>);
- 6) applicable live loads from platforms and walkways specified in 7.3.3.3; however, these live loads shall not be included in either the design of anchor bolts or the check for stability against wind or earthquake;

c) operation at design conditions:

- 1) dead load of structure;
- 2) dead load of equipment, including platforms supported by the equipment;
- 3) nozzle loads;
- 4) operating mass of fluid in equipment;
- 5) unbalanced forces from impact;
- 6) applicable live loads specified in 7.3.3.3; however, these live loads shall not be included in either the design of anchor bolts or the check for stability against wind or earthquake;
- 7) full wind load or earthquake load, whichever is greater.

Loading conditions of a special nature shall at all times receive proper consideration. (All loads and forces are additive.)

### 7.3.4 Plenums

7.3.4.1 Figure 9 shows typical plenum arrangements.

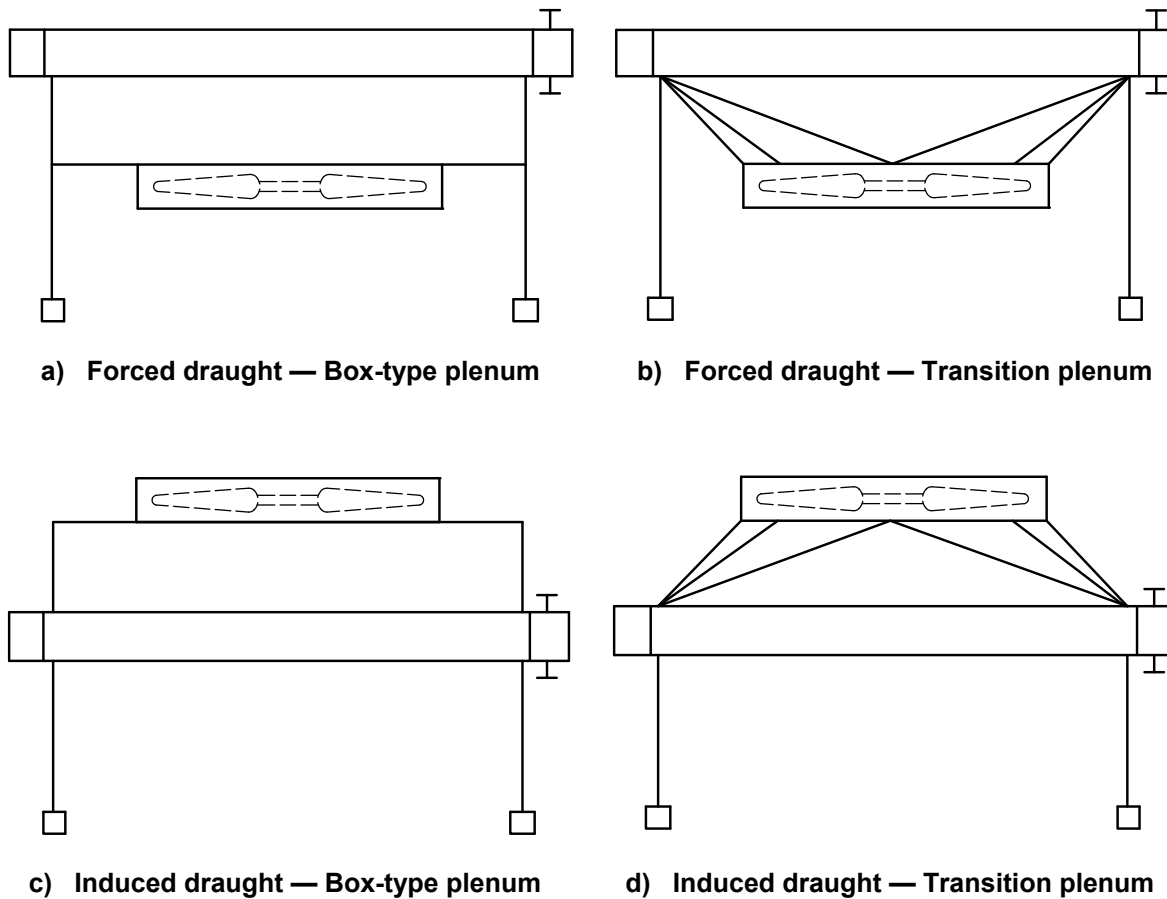

**Figure 9 — Typical Plenum Arrangements**

7.3.4.2 Box-type plenums employing panel construction shall be designed to form an integral part of the structure.

7.3.4.3 Bank arrangements for field-assembled units may be designed with common walls between adjacent plenums.

7.3.4.4 The plenums between the fan and the bundle shall be partitioned to prevent recirculation of air from operating fans through non-operating fans.

- 7.3.4.5 Plenum partition requirements for recirculation systems shall be as specified or agreed by the Purchaser. See Annex C.

7.3.4.6 The thickness of steel sheet material used in the construction of plenums shall be at least 1.9 mm (14 gauge USS; 0.08 in.) flat or 1.5 mm (16 gauge USS; 0.060 in.) ribbed.

7.3.4.7 The minimum plenum height shall be obtained from information provided in 7.2.3.4 and Figure 7.

**7.3.4.8** Fan decks shall be designed for a live load of 2500 N/m<sup>2</sup> (50 lbf/ft<sup>2</sup>) with a minimum thickness of 2.7 mm (12 gauge USS; 0.105 in.).

### **7.3.5 Mechanical Access Facilities**

- **7.3.5.1** The number and location of header access platforms, interconnecting walkways and ladders shall be specified by the Purchaser.

**7.3.5.2** If specified, maintenance platforms shall be provided beneath each drive assembly to provide access for removal and replacement of all drive components.

**7.3.5.3** Platforms shall have a clear width of at least 0.75 m (30 in.).

**7.3.5.4** The floor of the walkways, platforms, etc., shall be grating, expanded metal or a raised-pattern solid plate with drain holes. If raised-pattern steel is used, the thickness shall be at least 6 mm (<sup>1</sup>/<sub>4</sub> in.). Glass-reinforced plastic (GRP) shall be used, if specified by the Purchaser.

**7.3.5.5** Ladders, railings, toe plates, safety cages, etc., shall be of steel construction or, if specified by the Purchaser, another metal or GRP in accordance with local regulations. The following shall apply.

- a) Safety cages shall be provided for ladders over 3 m (10 ft) high.
- b) Chains with safety hooks or safety gates shall be provided across ladder openings at platforms.
- c) Ladders over 2 m (6 ft) high shall provide for side-step access to platforms, unless otherwise specified.

**7.3.5.6** Header platforms shall be provided with a toe-board on the side next to the exchanger. If the gap between the platform and the exchanger is greater than 150 mm (6 in.), a knee rail shall be fitted.

**7.3.5.7** If steel pipe railings are not galvanized, they shall be sealed to prevent internal corrosion.

- **7.3.5.8** The Purchaser shall specify requirements, if any, for personnel protection against high air-outlet temperatures and hot surfaces.

### **7.3.6 Lifting Devices**

**7.3.6.1** At least two lifting lugs shall be provided on each side frame of tube bundles and each louver section side frame. Lifting lugs on side frames of adjacent bundles shall be located so as not to interfere with bundle installation.

**7.3.6.2** Two lifting lugs shall be provided on each removable cover plate and each removable bonnet.

**7.3.6.3** Solid-forging or plate-type lifting lugs shall be used for tube bundle side frames, louver side frames, cover plates and bonnets. The opening in the lug shall be at least 40 mm (<sup>1</sup>/<sub>2</sub> in.) diameter.

**7.3.6.4** Sufficient lifting eyes shall be provided on each driver and gear to allow safe installation and dismantling. A structural member shall be provided with load attachment points for removal and replacement of driver components.

**7.3.6.5** Lug or eye design shall be based on a total load equal to twice the weight of the lift.

## **8 Materials**

### **8.1 General**

**8.1.1** Materials for pressure components shall be in accordance with the pressure design code.

**8.1.2** Cast iron shall not be used for pressure components in flammable, lethal or toxic service.

**8.1.3** Structural supports, such as side frames and beams, that are part of the tube bundle and not accessible for maintenance shall be galvanized, unless otherwise specified by the Purchaser or not permitted by 8.1.5.

**8.1.4** Galvanizing of structural steel shall be in accordance with ISO 1461.

**8.1.5** Galvanized materials or zinc-containing paints, etc., shall not be used in direct contact with or directly above exposed austenitic stainless steel or high-nickel alloy pressure components. Alternative coatings and/or materials shall be used.

**8.1.6** Combinations of construction materials shall be compatible such that electrolytic (galvanic) cells are minimized.

## **8.2 Requirements for Carbon Steel in Sour or Wet Hydrogen Sulfide Service**

**8.2.1** Materials shall be supplied in the normalized condition, unless otherwise approved by the Purchaser. The acceptability of hot formed material shall be subject to approval of the Purchaser.

**8.2.2** Pressure-retaining components shall be supplied with a certified material test report (CMTR). The CMTR shall include the unspecified elements chromium (Cr), columbium (Cb) (also known as niobium [Nb]), nickel (Ni), vanadium (V), molybdenum (Mo), and copper (Cu) that are used in the equation to calculate the carbon equivalent (CE) as defined by ISO 15156 (all parts) or NACE MR0103.

- **8.2.3** The maximum allowable carbon equivalent shall be agreed with the Purchaser prior to purchase of materials being used in fabrication. Restrictions on other residual elements and micro-alloying elements may also apply depending on the severity of the service. The Purchaser shall specify any such restrictions.

## **8.3 Headers**

**8.3.1** External load-bearing parts welded to headers shall be of the same nominal composition as the material to which they are welded.

**8.3.2** Welded header pass partitions and stiffeners shall be of the same material type as the header plate.

**8.3.3** Tube access header plug material shall be compatible with the header material. Cast iron shall not be used for plug material.

**8.3.4** Tube access header plugs of carbon steel bar-stock material or individual forged plugs shall be of a material allowed by the pressure design code (e.g. ASME BPVC II, SA-105).

**8.3.5** Precautions should be taken to avoid galling between the plugs and the plug sheet.

## **8.4 Louvers**

**8.4.1** Louver blade pivot pins shall be austenitic stainless steel or UNS A96063 aluminum alloy in the T6 temper condition.

**8.4.2** Louver bearings shall be of either polytetrafluoroethylene (PTFE) base composite material containing at least 20 % fill (exposure temperatures shall be in accordance with 7.2.10.10), or an approved alternative if required for a higher design temperature.

**8.4.3** Steel louver blades and frames shall be galvanized. If mill-galvanized material is used, all cut and punched edges shall be protected by a zinc-rich coating.

## **8.5 Other Components**

**8.5.1** Fin material shall be aluminum, unless otherwise specified or agreed by the Purchaser.

**8.5.2** Fan blades shall be of aluminum alloy or GRP, unless otherwise specified.

**8.5.3** Plugs for threaded connections, such as vents, drains and instrument connections, shall be of the same material type as the connection.

**8.5.4** Plenums, fan decks, partitions, platforms and fan rings shall be of carbon steel unless otherwise specified.

**8.5.5** Metal gasket material shall be softer than the gasket contact surface.

**8.5.6** Solid metal gaskets for shoulder plugs shall have a Rockwell hardness no greater than HRB 68 for carbon steel or HRB 82 for austenitic stainless steel.

## **9 Fabrication of Tube Bundle**

### **9.1 Welding**

#### **9.1.1 General**

**9.1.1.1** Welding procedures and welders shall be qualified in accordance with the pressure design code. Welding shall be performed in accordance with the pressure design code.

**9.1.1.2** All pressure-containing header welds and nozzle welds shall have full penetration and full fusion.

**9.1.1.3** The root pass of single-side welded joints without backing strips shall be made using gas metal arc welding (GMAW), gas tungsten arc welding (GTAW) or low-hydrogen shielded metal arc welding (SMAW).

**9.1.1.4** Enclosed spaces between any welded attachment and the headers shall be vented by a 3 mm ( $\frac{1}{8}$  in.) diameter drilled hole.

- **9.1.1.5** The Purchaser shall specify whether weld procedure qualifications for carbon steel in sour or wet hydrogen sulfide service, including tube to tubesheet welds, shall include a micro-hardness survey performed on a weld cross-section and transverse to the weld centerline. The micro-hardness testing and acceptance criteria shall be in accordance with NACE SP0472 or ISO 15156 (all parts), as applicable. Any additional restrictions on class, grade, residual elements or micro-alloying elements for the qualification test material shall be specified by the Purchaser.

#### **9.1.2 Plug Headers**

**9.1.2.1** Partition plates shall be seal-welded to abutting tubesheet and plugsheet plates and shall be welded from both sides; a full-penetration weld joint preparation shall be used. Seal welds on the ends of internal pass partition plates are excluded from this requirement.

**9.1.2.2** If pass partition plates are also used as stiffeners, a full-penetration configuration shall be used and weld joint efficiencies shall be in accordance with the pressure design code.

### 9.1.3 Removable Cover Plate and Removable Bonnet Headers

9.1.3.1 Removable cover plate flanges and removable bonnet header flanges shall be installed with full penetration welding.

9.1.3.2 Partition plates and stiffeners shall be welded from both sides, along the full length of the three edges.

## 9.2 Postweld Heat Treatment

9.2.1 All carbon steel and low-alloy chromium steel headers shall be subjected to postweld heat treatment. Welded tube-to-tubesheet joints shall be excluded unless required by the pressure design code or specified by the Purchaser.

9.2.2 Gaskets made of ferritic materials and fabricated by welding shall be fully annealed after welding.

9.2.3 For sour or wet hydrogen sulfide service, the minimum PWHT requirements for header boxes with carbon steel construction shall be in accordance with NACE SP0472.

## 9.3 Tube-to-Tubesheet Joints

### 9.3.1 Tube Hole Diameters and Tolerances

9.3.1.1 Tube holes in tubesheets shall be finished to the sizes and under-tolerances shown under "Standard fit" in Table 11.

9.3.1.2 If work hardening materials such as austenitic stainless steel, duplex stainless steel, titanium, copper-nickel or high-nickel alloy tubes are specified, the tube holes shall be machined in accordance with Table 11, "Special close fit".

9.3.1.3 No more than 4 % of the total number of tube holes in a tubesheet may exceed the over-tolerances shown under "Over-tolerance" in Table 11. No tube holes shall exceed the nominal tube-hole diameter given in Table 11 by more than 0.25 mm (0.01 in.).

### 9.3.2 Tube-hole Grooving

9.3.2.1 All tubesheet holes for expanded joints in tubesheets less than 25 mm (1 in.) thick shall be machined with one groove approximately 3 mm ( $1/8$  in.) wide and 0.4 mm ( $1/64$  in.) deep. A second groove shall be provided for tubesheets 25 mm (1 in.) or greater in thickness.

9.3.2.2 Tube-hole grooves shall be square-edged, concentric, and free of burrs.

9.3.2.3 Grooves shall be located at least 3 mm ( $1/8$  in.) plus the corrosion allowance from the process face of the tubesheet and at least 6 mm ( $1/4$  in.) from the air-side face of the tubesheet.

### 9.3.3 Expanded Tube-to-Tubesheet Joints

9.3.3.1 Tubes shall be expanded into the tubesheet for a length at least the smaller of the following:

- a) 50 mm (2 in.);
- b) tubesheet thickness less 3 mm ( $1/8$  in.).

In no case shall the expanded portion extend beyond the air-side face of the tubesheet.

**Table 11 — Nominal Tube Hole Diameters and Tolerances**

Dimensions in millimeters (in.)

Nominal Tube OD	Standard Fit		Special Close Fit		Over-tolerance
	Nominal Tube Hole Diameter	Under-tolerance	Nominal Tube Hole Diameter	Under-tolerance	
19.05 ( <sup>3</sup> / <sub>4</sub> )	19.30 (0.760)	0.10 (0.004)	19.25 (0.758)	0.05 (0.002)	0.05 (0.002)
25.40 (1)	25.70 (1.012)	0.10 (0.004)	25.65 (1.010)	0.05 (0.002)	0.05 (0.002)
31.75 (1 <sup>1</sup> / <sub>4</sub> )	32.11 (1.264)	0.15 (0.006)	32.03 (1.261)	0.08 (0.003)	0.08 (0.003)
38.10 (1 <sup>1</sup> / <sub>2</sub> )	38.56 (1.518)	0.18 (0.007)	38.46 (1.514)	0.08 (0.003)	0.08 (0.003)
50.80 (2)	51.36 (2.022)	0.18 (0.007)	51.26 (2.018)	0.08 (0.003)	0.08 (0.003)

**9.3.3.2** The expanding procedure shall provide uniform expansion throughout the expanded portion of the tube without a sharp transition to the unexpanded portion.

**9.3.3.3** The ends of tubes shall extend at least 1.5 mm (<sup>1</sup>/<sub>16</sub> in.) and not more than 10 mm (<sup>3</sup>/<sub>8</sub> in.) beyond the tubesheet.

**9.3.4 Welded Tube-to-Tubesheet Joints**

- **9.3.4.1** The Purchaser shall specify whether it is necessary that the tube-to-tubesheet joints be strength- or seal-welded.

**9.3.4.2** If welding is used for sealing the tube-to-tubesheet joint and customary tube loads are carried by the expanded joint (seal-welded joint), the joints shall comply with 9.3.1, 9.3.2, and 9.3.3.

**9.3.4.3** If welded-only tube joints are used as a complete substitute for expanded and strength-welded joints, the requirements of 9.3.1, 9.3.2, and 9.3.3 may be modified if agreed between the Vendor and the Purchaser.

**9.3.4.4** Recessed-type tube-to-tubesheet welds (in the tube holes) shall not be used.

**9.4 Gasket Contact Surfaces**

**9.4.1** Final machining of gasket contact surfaces for removable cover plates shall be done after any postweld heat treatment.

**9.4.2** Gasket contact surfaces of removable bonnet headers and removable cover plate headers shall be flat, with a maximum deviation over the entire length of 0.8 mm (<sup>1</sup>/<sub>32</sub> in.). The flatness of tubesheet gasket contact surfaces shall be measured after expanding or welding of the tubesheet joints.

**9.4.3** Plug gasket contact surfaces shall be machined to a finish of average roughness between 1.6 µm and 3.2 µm (63 µin. and 125 µin.).

## 9.5 Thread Lubrication

9.5.1 Plug threads shall be coated with a suitable thread lubricant.

9.5.2 Header flange bolting shall be assembled using a thread lubricant suitable for the operating temperature.

## 9.6 Alignment and Tolerances

9.6.1 Standard tolerances for the dimensions of air-cooled heat exchangers and for nozzle locations are shown in Figure 10. Tolerances apply to both forced-draught and induced-draught exchangers.

9.6.2 Header warpage shall be not more than 12 mm ( $1/2$  in.) or 5 mm/m ( $1/16$  in./ft), whichever is the lesser.

9.6.3 Bundles that will be stacked in service shall be trial assembled in the fabricating shop to confirm tolerance.

9.6.4 Manufacturing tolerances shall be such that nominally identical parts shall be interchangeable.

## 9.7 Assembly

Air-cooled heat exchangers shall be completely assembled for shipment except that, if complete assembly is impractical, they shall be partially shop-assembled into the largest practical sub-items to minimize field assembly work. The completeness of assembly for shipment shall be agreed between the Purchaser and the Vendor (see 5.4).

## 10 Inspection, Examination, and Testing

### 10.1 Quality Control

10.1.1 On components subject to full radiography, nozzle attachment welds that cannot be readily examined by radiography in accordance with the pressure design code shall have their root pass and final pass fully examined by the magnetic-particle or liquid-penetrant method after back-chipping or gouging (where applicable).

10.1.2 If full radiographic or ultrasonic examination is not specified, at least one spot radiographic or ultrasonic examination shall be made of a longitudinal outside pressure weld and an end-closure weld for each header. Process nozzle attachment welds shall be examined by the magnetic-particle or liquid-penetrant method; this examination shall apply to the root pass after back-chipping or flame-gouging (where applicable) and to the completed weld.

10.1.3 Spot radiographic or ultrasonic examinations shall include each start and stop of weld made by the automatic submerged arc-welding process and repaired areas of burn-through.

10.1.4 Spot radiographic or ultrasonic examinations shall cover either a length of at least 250 mm (10 in.) or the full length if the weld is less than 250 mm (10 in.) long.

10.1.5 For stainless steel and for ferritic alloy steel with a chromium content greater than 0.5 %, the root pass and final passes of welds not subject to full radiography shall be examined by the magnetic-particle or liquid-penetrant method.

10.1.6 If the plates are not fully examined for laminations by ultrasonic examination and if set-on connections are used, the edge of the hole in the plate to which the connections are attached shall be examined for laminations by the magnetic-particle or liquid-penetrant method. Indications found shall be cleared to sound metal and then back-welded.

Tolerances in millimeters (in.)

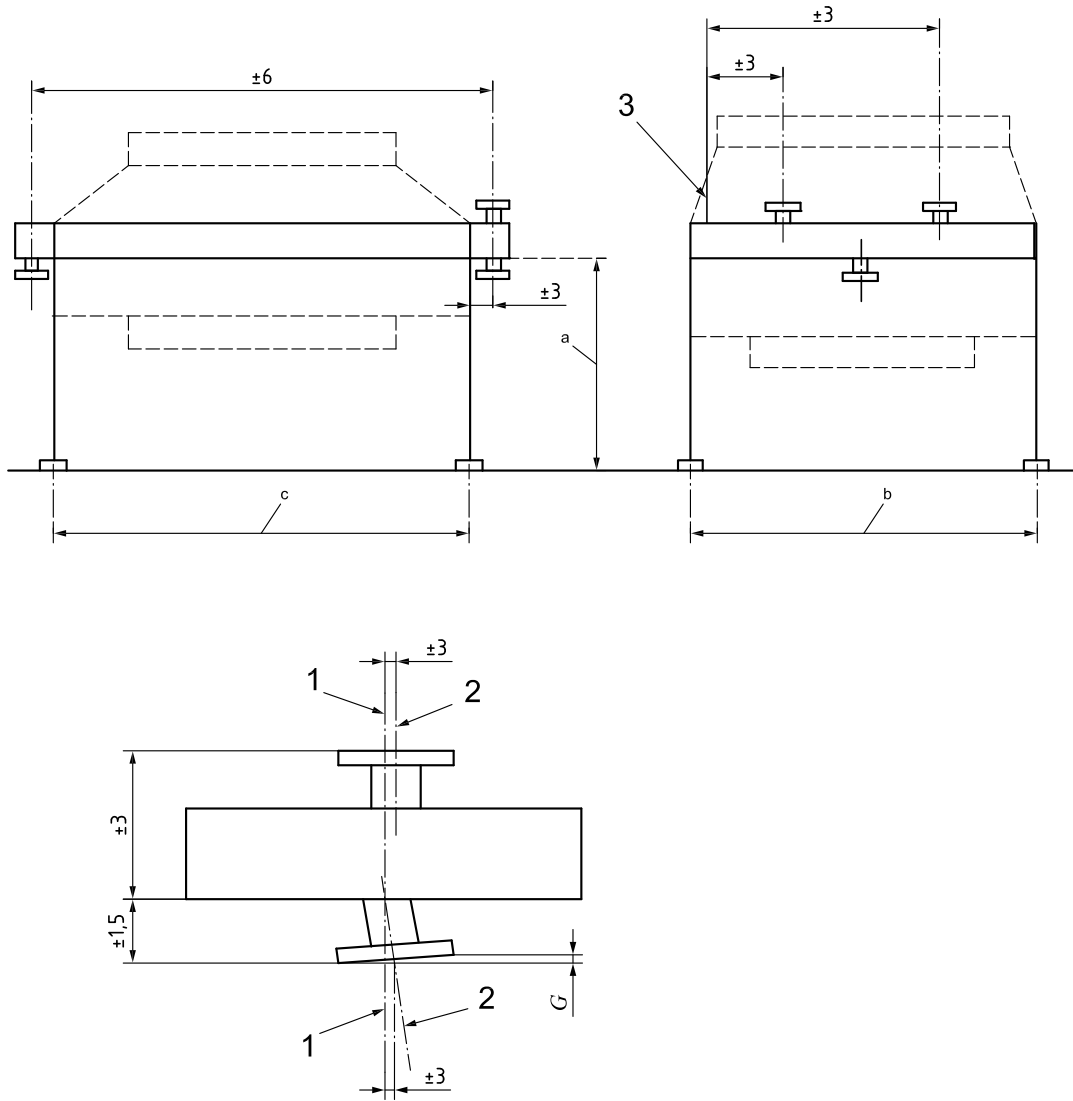

**Key**

- 1 centerline header
- 2 centerline nozzle
- 3 reference line
- G out-of-plane tolerance, as given below:

Nominal nozzle size DN (NPS)	Maximum out-of-plane tolerance G mm (in.)
50 to 100 (2 to 4)	1.6 ( <sup>1</sup> / <sub>16</sub> )
150 to 300 (6 to 12)	2.4 ( <sup>3</sup> / <sub>32</sub> )
> 300 (> 12)	4.8 ( <sup>3</sup> / <sub>16</sub> )
stacked, all	0.8 ( <sup>1</sup> / <sub>32</sub> )

- a  $\begin{smallmatrix} +1 \\ -2 \end{smallmatrix}$  per meter.
- b  $\pm 1$  per meter.
- c  $\pm 3$  ( $W_p$  to 3 m;  $\begin{smallmatrix} +1 \\ -2 \end{smallmatrix}$  for each additional meter).

**Figure 10 — Standard Tolerances**

**10.1.7** Production hardness testing shall be as follows.

- a) Pressure-retaining welds in components made of carbon, Cr-Mo, 11/13/17 % chromium, and duplex stainless steels shall be hardness tested. Hardness testing of the heat-affected zone shall be conducted if required by the pressure design code, or when specified by the Purchaser.
- b) Hardness readings shall be taken with a portable Brinell hardness tester. Other hardness testing techniques may be employed if approved by the Purchaser. When access is available, tests shall be performed on the side of the weld in contact with the process fluid.
- c) Examination shall be made after any required postweld heat treatment.
- d) Unless otherwise agreed between the Vendor and Purchaser, the weld hardness shall not exceed the values listed in Table 12.
- e) Representative welds, including connection-to-header welds, shall be examined. Examination shall be made of one longitudinal weld, one weld at an end closure, and each connection-to-header weld if the connection is DN 50 (NPS 2) or larger. At least one header per item and every tenth header shall be examined.
- f) Hardness test results and locations shall be recorded.

**Table 12 — Maximum Weld Hardness**

Material	Maximum Weld Hardness
Carbon steel	225 HBW
Chromium steel (up to 3 % Cr)	225 HBW
Chromium steel (5 % Cr to 17 % Cr)	241 HBW
Duplex stainless steel (22 % Cr)	by agreement with Purchaser
Super duplex stainless steel (25 % Cr)	by agreement with Purchaser
NOTE These hardness values are for general services. More stringent hardness testing and acceptance criteria can be required for special services (e.g. sulfide stress cracking or other types of environmental cracking services as specified in NACE standards).	

**10.1.8** For tubes with circumferential welds, the Vendor shall demonstrate by means of a qualification procedure that weld-root penetration on the tube inside diameter does not exceed 1.5 mm ( $1/16$  in.). Permanent backing rings shall not be used.

**10.1.9** Inspection of tubes with circumferential welds shall be as follows.

- a) At least 10 % of the welded joints selected at random shall be examined using radiography. One double-wall elliptical exposure for double-wall viewing shall be taken for each joint.
- b) Sampling shall be done progressively throughout the period of fabrication.

**10.1.10** Bar stock material for tube access plugs shall be radially examined by an ultrasonic or radiographic method. There shall be no linear indications exceeding 10 mm ( $3/8$  in.).

**10.1.11** It is not necessary that individually forged tube access plugs, either hot- or cold-forged, be examined in accordance with 10.1.10.

- **10.1.12** If specified by the Purchaser, all carbon steel plate in sour or wet hydrogen sulfide service shall be subjected to an ultrasonic lamination check (e.g. to EN 10160 grade S2E2 or ASTM A578, acceptance level A supplementary requirement S1).

**10.1.13** For austenitic and duplex stainless steels, the ferrite content of all accessible completed production welds shall be checked using a ferritescope. A minimum of three tests shall be made on each 1.5 m (5 ft) of weld, with at least three tests made on each header box longitudinal weld, three tests on each end plate weld, and three tests on each nozzle weld. The acceptance criteria for the minimum and maximum ferrite content shall be agreed between the Purchaser and Vendor.

**10.1.14** Where nozzle pipe and transitions are fabricated from plate, the welds shall be subject to 100 % radiography after final forming or after any required heat treatment.

## **10.2 Pressure Test**

**10.2.1** Hydrostatic tests shall be in accordance with the pressure design code.

**10.2.2** Hydrostatic test pressure shall be maintained for at least 1 h.

**10.2.3** Water used for hydrostatic testing shall be potable. The chloride content of the test water used for equipment with austenitic stainless steel or Ni-Cu alloy materials that is exposed to the test fluid shall not exceed 50 mg/kg (50 parts per million by mass). Upon completion of the hydrostatic test, the equipment shall be promptly drained.

**10.2.4** Unless otherwise specified by the Purchaser, paint or other coatings may be applied over welds prior to the final pressure test.

**10.2.5** Joints taken apart after the final pressure test shall be reassembled with new gaskets.

- **10.2.6** Other types of test, such as helium tests, or additional requirements for equipment drying or preservation, shall be performed if specified by the Purchaser.

## **10.3 Shop Run-in**

- The extent of shop run-in tests of the driver, the drive assembly, and the fan of shop-assembled units shall be a matter of agreement between the Purchaser and the Vendor.

## **10.4 Equipment Performance Testing**

- If a performance test is specified by the Purchaser, e.g. to check the guaranteed performance of the exchanger unit, it shall be in accordance with ASME PTC 30, or other standard if agreed to by the Purchaser.

## **10.5 Nameplates**

**10.5.1** An austenitic stainless steel nameplate shall be affixed to the inlet header of each tube bundle indicating the item number and shall contain marking required by the pressure design code and any other information specified by the Purchaser.

**10.5.2** The nameplate shall be permanently mounted on a bracket welded to the top of the header.

**10.5.3** The following parts shall be stamped with the Vendor's serial number:

- a) header;
- b) cover plate flange of cover plate headers;

c) tubesheet flange of bonnet headers.

## 11 Preparation for Shipment

### 11.1 General

11.1.1 All liquids used for cleaning or testing shall be drained from units before shipment.

11.1.2 Tube bundles shall be free of foreign matter prior to shipment.

11.1.3 Exposed flanged connections shall be protected by either of the following:

a) gasketed steel covers fastened by the greater of the following:

- 1) 50 % of the required flange bolting,
- 2) four bolts; or

b) commercially available plastic covers specifically designed for flange protection.

- 11.1.4 The extent of skidding, boxing, crating, protection or coating for shipment shall be specified or agreed to by the Purchaser.

11.1.5 Each loose piece or assembly shall be properly protected to prevent damage during normal shipping and handling.

### 11.2 Surfaces and Finishes

11.2.1 Surfaces being painted shall be degreased and cleaned by wire brushing or a similar means to remove loose scale, dirt, and other foreign materials.

11.2.2 Machined surfaces that are exposed to the atmosphere in transit and subsequent storage shall be protected with an easily removable rust preventative.

11.2.3 Unless otherwise specified, carbon steel and low-alloy headers shall be blast-cleaned in accordance with ISO 8501-1, grade Sa 2<sup>1/2</sup>, and then coated with an inorganic zinc-rich primer to a dry-film thickness of at least 50 µm (0.002 in.).

11.2.4 Other than tube surfaces, all exposed ferrous surfaces (not otherwise coated) shall be given one coat of the manufacturer's standard shop primer before shipment.

### 11.3 Identification and Notification

11.3.1 All separate parts shall be marked for identification.

11.3.2 The Vendor shall advise the Purchaser if bundles are temporarily fixed to bundle frames for shipping. Transit and erection clips or fasteners shall be clearly identified on the equipment and the field assembly drawings to ensure removal before commissioning of the exchanger.

## 12 Supplemental Requirements

### 12.1 General

- Section 12 provides additional design, fabrication and examination requirements that shall apply if specified by the Purchaser. In general, these supplemental requirements should be considered if the design pressure exceeds 14,000 kPa gauge (2000 psig).

## 12.2 Design

**12.2.1** Header corner-joint design shall provide for clear interpretation of weld quality in accordance with the pressure design code. The Vendor shall include in the proposal a drawing showing full details of the proposed welded joint design.

**12.2.2** All tubes shall be either seal-welded or strength-welded to the tubesheet. Low-alloy chromium steel tubes shall not be used in this application.

## 12.3 Examination

**12.3.1** Ultrasonic examination shall be performed on plates and forgings welded to other components if the thickness exceeds 50 mm (2 in.).

**12.3.2** Ultrasonic examination shall be performed on all forgings exceeding 100 mm (4 in.) thickness, except for bolted flat covers and standard flanges.

**12.3.3** All external pressure boundary welds, with the exception of tube-to-tubesheet welds, shall be either ultrasonically or radiographically examined.

**12.3.4** After ultrasonic examination of plates, forgings and welds has been performed, the Purchaser shall be supplied with a report that includes diagrams of the surfaces scanned, the indications obtained, the areas repaired, the nature of defects repaired and the repair procedures used. The following information shall be provided:

- a) pulse-echo unit manufacturer, model, and damping control setting;
- b) search unit manufacturer, model, dimensions, and the substance (such as oil or water) that is used to couple the transducer with the material being inspected;
- c) frequency used and the test angle on the component's surface; and
- d) wedge medium for angle-beam examination.

**12.3.5** The external pressure boundary root and final weld passes shall be examined by the magnetic-particle or liquid-penetrant method. This requirement excludes tube-to-tubesheet welds.

**12.3.6** Ultrasonic or radiographic examination shall be performed on all weld repairs after postweld heat treatment.

**12.3.7** Prior to welding, a magnetic-particle or liquid-penetrant examination shall be performed on all edges and plate openings prepared for welding. Defects found shall be cleared to sound metal.

**12.3.8** A magnetic-particle or liquid-penetrant examination shall be performed on all attachment welds (e.g. supports).

**12.3.9** A magnetic-particle or liquid-penetrant examination shall be made of areas where temporary lugs have been removed; these areas shall be prepared for examination by grinding.

**12.3.10** After hydrostatic testing, all exterior pressure-retaining welds and all interior nozzle welds that are accessible without disassembly shall be examined by the magnetic-particle or liquid-penetrant method.

**12.3.11** For pipe-manifold-type header construction, all boss-to-tube and tube-to-U-bend welds shall be 100 % examined by radiography or ultrasonic testing. Boss-to-header welds shall be examined externally by the magnetic-particle or liquid-penetrant method.

**12.3.12** Non-destructive examinations and acceptance criteria shall comply with the pressure design code.

**12.3.13** If postweld heat treatment is required, the tests within 12.3 shall be performed after completion of the postweld heat treatment.

**12.3.14** Prior to use in the fabrication of the bundle, all welded tubes shall be eddy-current tested and pressure tested.

## **12.4 Testing**

**12.4.1** A shop-air test at 100 kPa gauge to 170 kPa gauge (15 psig to 25 psig) shall be applied after tube-to-tubesheet welding, prior to tube expansion. Tube-to-tubesheet joints shall be examined for leaks by applying a soap solution.

**12.4.2** After the final pressure test, plug joints and all gasketed joints shall be air-tested at 100 kPa gauge to 170 kPa gauge (15 psig to 25 psig), testing for leaks either by applying a soap solution or by total immersion in a water tank.

# Annex A (informative)

## Recommended Practices

### A.1 Introduction

This annex has been prepared to give advice in areas outside the scope of this standard. The advice is not mandatory and is offered for guidance only.

### A.2 General — Selection of Induced Draught or Forced Draught — Guidance to 4.2

Forced-draught fans should be used, except that induced-draught fans should be considered for the following situations:

- a) if temperature control of the process is critical and sudden downpour of rain (i.e. excessive cooling) can cause operating problems;
- b) to minimize the risk of hot-air recirculation;
- c) on sites where air-side fouling is a significant problem, however forced draft can be used if screens are specified;
- d) to improve thermal performance in the event of a fan failure (due to the stack effect);
- e) in hot climates, where the fan plenum chamber shields the bundle from the sun;
- f) for services that have a temperature approach of 11 °C (20 °F) or less.

NOTE Temperature approach is the difference between process outlet temperature and air entering temperature.

### A.3 Design

#### A.3.1 Multi-pass Condensers — Guidance to 7.1.1.7

Multi-pass condensers which

- operate in vacuum service,
- have a separate aqueous phase and a minimum ambient temperature less than 0 °C (32 °F), or
- are expected to operate partially flooded, as specified by the Purchaser on the equipment data sheets,

should have the tubes in each pass, including any sub-cooling pass, sloped 10 mm/m ( $\frac{1}{8}$  in./ft) in the direction of flow.

#### A.3.2 Cyclic Design — Guidance to 7.1.1.12

The following is guidance to assist in identifying a potential cyclic service application:

- 20 % variance in normal operating pressure;

- 20 % variance in process flow rate;
- variations in normal operating temperature that exceed 110 °C (200 °F);

where for one cycle the variance occurs in a time frame of less than 24 h and number of cycles exceeds 12 per year.

NOTE The variation in the normal operating temperature is suggested by API RP 571-11, Section 4.2.9.3.c.

### A.3.3 Tubes and Finning — Guidance to 7.1.11

**A.3.3.1** The maximum process temperature for various types of fin bonding should be as given in Table A.1. The fin selection temperature is the temperature at the interface between the liner tube and the fin at maximum normal operating conditions. The maximum process temperature is a good approximation of the fin selection temperature.

**Table A.1 — Maximum Fin Selection Temperature for Fin Bonding Types**

Fin Bonding Type	Maximum Process Temperature °C (°F)
Embedded fins	400 (750)
Externally bonded (hot-dip galvanized steel fins)	360 (680)
Extruded fins	300 (570)
Footed fins (single L) and overlap footed fins (double L)	130 (270)
Knurled footed fin, either single L or double L	200 (390)
Externally Bonded (welded or brazed fins)	> 400 (750) (maximum should be agreed by Purchaser)
Except where stated otherwise, the above limits are based on a carbon steel core tube and aluminum fins; different materials for the core tube and/or the fins may result in a different temperature limit and the manufacturer shall be consulted.	

**A.3.3.2** Serrated, segmented and louvered fins, and fins with spacing tabs have a slightly higher air-side film coefficient. The disadvantage, however, is that they are more susceptible to air-side fouling and are more difficult to clean due to the sharp edges at the discontinuities. They should only be considered for low-fouling duties.

**A.3.3.3** In areas prone to air-side fouling due to airborne particulates, the maximum fin density should not exceed 394 fins per meter (10 fins per in.) and the minimum gap between the fins on adjacent tubes should be 6.4 mm ( $1/4$  in.) to allow effective cleaning of the fins.

**A.3.3.4** Tube supports should be designed such that mechanical loads are transferred to the tube cores.

**A.3.3.5** For elliptical tubes, the minimum tube wall thickness shall be as specified in 7.1.11.3.

**A.3.3.6** The minimum dimensions of elliptical tubes shall be: short axis 14 mm ( $9/16$  in.), long axis 36 mm ( $1\frac{7}{16}$  in.).

**A.3.3.7** For elliptical tubes the maximum process temperatures for selecting the type of fin bonding shall be in accordance with A.3.3.1.

**A.3.4 Tube-to-Tubesheet Joint Calculations — Guidance to 7.1.6.1.3**

During the inquiry phase, the Purchaser should specify the operating cases requiring the tube-to-tubesheet calculations; special consideration should be given to cases with the largest tube metal temperature differences between tube rows or passes.

**A.3.5 Fans — Guidance to 7.2.3**

**A.3.5.1** Variable-speed (speed frequency controlled, SFC) fans or automatic variable-pitch (AVP) fans may be used for process control.

**A.3.5.2** If there are stringent noise limitations during night-time and if, due to a lower air-inlet temperature at night-time, the air flow rate can be reduced, variable-speed fans should be used.

**A.3.6 Maximum Allowable Nozzle Loads — Guidance to 7.1.10**

Where the Purchaser specifies piping loads in excess of the nozzle loads shown in 7.1.10.2, these higher nozzle loads can require stiffening of the heat exchanger components and structural supports, and will increase the loads on the supporting pipe-racks or foundations. This can result in higher fabrication and erection cost of the exchanger and supporting structure.

**A.3.7 Walkways and Platforms — Guidance to 7.3.5**

Open grating should be used for the maintenance floor underneath the fan inlets to reduce air-side pressure drop. If solid plate is used, the effect on air-side pressure drop should be taken into account. To minimize this effect, a larger distance from the maintenance floor to fan inlet can be required.

**A.3.8 Selection of Header Type — Guidance to 7.1.6**

**A.3.8.1** Header types should be selected in accordance with Table A.2.

**Table A.2 — Header Selection**

Header Type	Design Pressure kPa gauge (psig)
Plug type headers, removable cover plate headers or bonnet type headers	< 3000 (435)
Plug type headers	≥ 3000 (435) and/or for hydrogen service

**A.3.8.2** For fluid streams with a fouling resistance greater than 0.00034 m<sup>2</sup>·K/W (0.00193 °F·ft<sup>2</sup>·h/Btu), or if fouling layers are expected that cannot be removed by chemical means, the bundle construction shall be suitable for mechanical cleaning.

**A.3.8.3** In heat exchangers having a condensing duty, the passes for the condensing phase should extend over the full width of the bundle. In case of total condensation, the size of the outlet nozzles should be such that flooding of the bottom rows of tubes cannot occur.

### **A.3.9 Air Design Temperature — Guidance to 7.2**

**A.3.9.1** To determine the air design temperature, the higher of the following temperatures may be used for non-critical processes:

- the highest air temperature that is exceeded for 400 h/y;
- the highest air temperature that is exceeded for 40 h/y, less 4 °C (7 °F).

**A.3.9.2** For critical processes, the air design temperature shall be the highest air temperature that is exceeded for 40 h/y.

**A.3.9.3** For an optimum design, the following temperatures should be specified, together with alternative process conditions specified in 7.1.6.1.1:

- minimum design metal temperature;
- design metal temperature;
- minimum ambient temperature;
- design ambient temperature;
- fin selection temperature.

### **A.3.10 Air Side Design — Guidance to 7.2.1**

**A.3.10.1** Pipe rack mounted bays require special consideration when determining the adequacy of air entering air-cooled heat exchangers. Normally, if the height of the pipe rack above grade is equal to or greater than one half the length of the air-cooled heat exchanger tubes, the air-cooled heat exchanger has mechanical equipment walkways located beneath the bays, and if the area directly below the mechanical equipment walkways provides a 50 % or greater net free area, then adequate air flow can be expected.

**A.3.10.2** Several banks of air-cooled heat exchangers located in one plant, or in one process area, can affect the operation of other bays by the recirculation of hot air exiting from one bay entering the air flowing into another, or the same, bay. This is termed “hot air recirculation” and can be controlled by the judicious placement of the units with respect to one another, as well as taking the prevailing winds into consideration. Computational fluid dynamics (CFD) computer programs are available for modeling plant sites to determine the amount of hot air recirculation that can occur under different conditions. CFD programs can help in siting equipment and can provide an estimate of how much to increase the design air temperature of air entering the air-cooled heat exchangers. An accurate design air entering temperature is especially important in cases where process temperatures are close to (i.e. nearly the same as) the design air entering temperatures.

**A.3.10.3** Forced draft and induced draft air-cooled heat exchangers should not be located adjacent to each other due to the potential for unwanted hot air recirculation.

### **A.3.11 Bearing Lubrication — Guidance to 7.2.5**

To allow proper lubrication, it should be ensured that the new grease displaces the maximum amount of old grease and automatically ejects any surplus to the outside; this should be achieved either by the bearing design or by fitting an external relief device.

**A.3.12 Gaskets for Bonnet or Cover-plate Type Headers — Guidance to 7.1.6.2 and 7.1.8**

**A.3.12.1** Gasket types are given in Table A.3 and the required gasket contact face surface finish is given in Table A.4.

**A.3.12.2** Gaskets shall not contain asbestos.

**A.3.12.3** Service conditions are listed in Table A.5 and the gaskets should be selected using Table A.6.

**A.4 Materials**

**A.4.1 Welded Tube Ends — Guidance to 9.2.1 and 12.2.2**

Where welded tube ends are specified or required, tube and tubesheet materials should be selected such that a PWHT of the tube ends welds can be avoided. Low-alloy chromium steel (i.e. 1 % Cr to 9 % Cr) material is not recommended when tube end welding is specified, due to exposure of the aluminum fins to high temperatures during the PWHT process.

**A.4.2 Tube-to-Tubesheet Joint — Guidance to 9.3**

**A.4.2.1** For heat exchangers in hydrogen service, tube-to-tubesheet joints should be welded and expanded.

**A.4.2.2** If weld overlay or cladding of the tubesheet is specified to eliminate the effects of welding dissimilar materials, a 4.8 mm (<sup>3</sup>/<sub>16</sub> in.) minimum overlay or clad should be provided. The overlay or cladding should have the same metallurgy as the tubes.

**Table A.3 — Gasket Types**

Description		Minimum Width mm (in.)	Minimum Thickness mm (in.)
1	Aramid-fiber-filled NBR, oil and acid resistant	9.5 ( <sup>3</sup> / <sub>8</sub> )	2 ( <sup>5</sup> / <sub>64</sub> )
2	Compressed sheet composition, oil or acid resistant	9.5 ( <sup>3</sup> / <sub>8</sub> )	1.6 ( <sup>1</sup> / <sub>16</sub> )
3	Flat metal-jacketed, soft iron, filled	12.5 ( <sup>1</sup> / <sub>2</sub> )	3.2 ( <sup>1</sup> / <sub>8</sub> )
4	Flat metal-jacketed, stainless, filled	12.5 ( <sup>1</sup> / <sub>2</sub> )	3.2 ( <sup>1</sup> / <sub>8</sub> )
5	Metal-reinforced PTFE layers	9.5 ( <sup>3</sup> / <sub>8</sub> )	1.6 ( <sup>1</sup> / <sub>16</sub> )
6	Metal-reinforced expanded graphite	9.5 ( <sup>3</sup> / <sub>8</sub> )	1.6 ( <sup>1</sup> / <sub>16</sub> )
7	Grooved gaskets with graphite layers <sup>a</sup>	12 ( <sup>1</sup> / <sub>2</sub> )	6.4 ( <sup>1</sup> / <sub>4</sub> ) or 3.2 ( <sup>1</sup> / <sub>8</sub> )

<sup>a</sup> The minimum thickness of grooved gaskets with graphite layers should be 3.2 mm (<sup>1</sup>/<sub>8</sub> in.) to provide a width-to-thickness ratio of 4 to 1.

**Table A.4 — Gasket Contact-surface Finish**

Gasket Type	R <sub>a</sub> Value	
	µm	(µin.)
1, 2, 5, 6, 7	3.2 to 6.3	(125 to 250)
3, 4	0.8 to 1.6	(32 to 64)

**Table A.5 — Service Conditions**

Service Condition	Description
I	Non-corrosive and mildly corrosive
II	Hydrocarbon streams containing sulfur compounds and naphthenic acids with an acid value exceeding 300 mg/kg KOH ( $300 \times 10^{-6}$ mass fraction KOH), and for maximum operating temperatures above 230 °C (446 °F)
III	Hydrocarbon streams containing sulfur compounds and naphthenic acids with an acid value not exceeding 300 mg/kg KOH ( $300 \times 10^{-6}$ mass fraction KOH) and for maximum operating temperatures above 330 °C (626 °F)
IV	Hydrocarbons containing hydrogen
V	Non-corrosive cooling water below 50 °C (122 °F)
VI	Mildly corrosive cooling water below 50 °C (122 °F)
VII	Corrosive cooling water below 50 °C (122 °F)
VIII	Frequent changes in temperature and pressure, (e.g. hot washing, dewaxing, chilling) and frequent cleaning (i.e. more than twice a year under all conditions I to VII)

**Table A.6 — Gasket Selection**

Service Condition	Design Temperature		Maximum Design Pressure		Recommended Type	Alternative Type
	°C	(°F)	kPa (ga)	(psig)		
I	-200 to 0	(-300 to 32)	3000	(435)	6	4
	0 to 150	(32 to 300)	2000	(290)	1	2, 5, 6
	0 to 240	(32 to 460)	3000	(435)	6	3
	240 to 450	(460 to 840)	3000	(435)	6	3
II	0 to 150	(32 to 300)	2000	(290)	1	2, 5, 6
	0 to 240	(32 to 460)	3000	(435)	6	3
	240 to 450	(460 to 840)	3000	(435)	6	4
III	330 to 450	(630 to 840)	3000	(435)	6	
IV	0 to 450	(32 to 840)	3000	(435)	6	
V, VI, VII	0 to 50	(32 to 120)			1 [3.2 mm ( <sup>1</sup> / <sub>8</sub> in.) thick]	2, 5, 6
VIII	0 to 450	(32 to 840)	6000	(870)	4	

## A.5 Preparation for Shipment Protection — Guidance to Section 11

**A.5.1** If water residues cannot be tolerated, equipment should be dried by one of the following methods:

- a) blowing dry air or nitrogen, of relative humidity less than 15 % (usually dehumidified), through the heat exchanger and monitoring the outlet air until the relative humidity falls below 30 %;

- b) evacuating the heat exchanger with a vacuum pump to an absolute pressure of between 0.4 kPa (0.06 psi) and 0.5 kPa (0.075 psi).

**A.5.2** After draining and drying, internal surfaces may be protected against corrosion by the addition of a desiccant (e.g. silica gel), by the addition of a volatile corrosion inhibitor, or by blanketing with an inert gas such as nitrogen [typically at gauge pressures from 35 kPa (5 psi) to 100 kPa (15 psi)].

## Annex B (informative)

### Checklist and Data Sheets <sup>6</sup>

#### Contents and Usage

The checklist and data sheets in this annex contain the information necessary for the description and design of air-cooled heat exchangers for petroleum and natural gas services.

The checklist is used to note the specific requirements the Purchaser shall make in response to the sections and subsections in this standard alongside which bullets (●) are used to indicate that more information is required or that it is necessary to make a decision.

Completion of the checklist is the responsibility of the Purchaser. Completion of the data sheets is the joint responsibility of the Purchaser and the Vendor. The Purchaser is responsible for the process data on the data sheets.

The transport properties shall be based on the total composition of each of the phases (water, steam, air, and hydrogen or another permanent gas), if these components are parts of a homogeneous phase. If the liquid has immiscible phases, the liquid properties shall be separately and completely specified for each phase. If the mentioned components are not included in the transport properties and they are present, their concentrations in the process stream shall be stated. In the simple case of a well-defined, no-change-of-phase service, the Purchaser may use the data sheets as the only document for data transmittal.

The Purchaser may submit the checklist and data sheets to the Vendor in a form other than that indicated herein.

---

<sup>6</sup> Users of instructions should not rely exclusively on the information contained in this document. Sound business, scientific, engineering, and safety judgment should be used in employing the information contained herein. Where applicable, authorities having jurisdiction should be consulted. Work sites and equipment operations may differ. Users are solely responsible for assessing their specific equipment and premises in determining the appropriateness of applying the instructions. At all times users should employ sound business, scientific, engineering, and judgment safety when using this standard.

<b>AIR-COOLED HEAT EXCHANGER CHECKLIST</b>		Job No. _____	Item No. _____
		Page: <u>  1  </u> of <u>  2  </u>	By _____
		Date _____	Revision _____
		Proposal No. _____	Contract No. _____
		Inquiry No. _____	Order No. _____
Subsection No.			
4.1	Pressure design code:		
4.4	Applicable local regulations:		
4.6	Is service designated as sour or wet hydrogen sulfide service?	Yes	No
4.7	Winterization requirement and type?		
5.7	Is noise data sheet required?	Yes	No
6.1.1	Which documents are to be submitted?  Which documents are subject to Purchaser's approval?		
6.1.3	Are calculations to be submitted for approval?	Yes	No
6.1.4	Are welding data to be submitted for approval?	Yes	No
6.1.6	Additional engineering information required:		
6.2.2	Final records to be furnished and whether they shall be in electronic form:		
7.1.1.11	Is internal steam-out design required?  Temperature, pressure and operating conditions:	Yes	No
7.1.1.12	Is cyclic service design required?  Type and magnitude of variation in pressure, temperature, flowrate, time for the variation and number of cycles or frequency:		
7.1.3.1	Maximum design temperature: Minimum design temperature: Minimum design metal temperatures:		
7.1.3.2	Maximum operating temperature for fin selection:		
7.1.4	Design pressure of tube bundle:		
7.1.5.1	Corrosion allowance:		
7.1.6.1.1	Is an analysis required of alternative operating conditions in design of headers?	Yes	No
7.1.9.7	Plane of process flanges if not horizontal:		
7.1.9.15	Chemical cleaning connection size, type, and location:		
7.1.11.2	Maximum tube length:		
7.1.11.7	Type of finned tube construction:		
7.1.11.12	Is heat treatment required after bending of U-tubes?	Yes	No

<b>AIR-COOLED HEAT EXCHANGER CHECKLIST</b>		Job No. _____	Item No. _____
		Page: <u>  1  </u> of <u>  2  </u>	By _____
		Date _____	Revision _____
		Proposal No. _____	Contract No. _____
		Inquiry No. _____	Order No. _____
Subsection No.			
7.2.1.1	Special environmental factors affecting air-side design:		
7.2.1.8	Is an estimate of design exposure temperatures for mechanical components required?	Yes	No
7.2.2.1	Location of noise level values:		
7.2.3.10	Use of automatic control for varying the blade pitch?	Yes	No
7.2.3.11 e	Any special blade pitch limit stop setting:		
7.2.7.1.1	Type of drive system:		
	Drive equipment supplier:	Purchaser	Vendor
7.2.7.2.1	Electric motor construction, supply and classification:		
7.2.7.2.9	Is a self-actuating braking device required?	Yes	No
7.2.7.3	Requirements for variable-speed drive systems:		
7.2.9.1	Are vibration cut-out switches required?	Yes	No
7.2.10.19	Louver position upon loss of control-air pressure:		
7.2.11.1	Are screens required? Type:	Yes	No
7.3.1.1	Structural code:		
7.3.2.2	Is shop test for vibration check required?	Yes	No
7.3.3.2	Extent and mass of fireproofing:		
7.3.3.11	Snow load:		
7.3.3.12	Exact type, location, magnitude, and direction of other design loads:		
7.3.4.5	Plenum partition requirements for recirculation systems:		
7.3.5.1	Number and location of header access platforms, interconnecting walkways and ladders:		
7.3.5.8	Are there any special requirements for personnel protection against high air-outlet temperature? If yes, state:	Yes	No

<b>AIR-COOLED HEAT EXCHANGER CHECKLIST</b>		Job No. _____	Item No. _____
		Page: <u>  1  </u> of <u>  2  </u>	By _____
		Date _____	Revision _____
		Proposal No. _____	Contract No. _____
		Inquiry No. _____	Order No. _____
Subsection No.			
8.2.3	Maximum allowable Carbon Equivalent: Restrictions on other residual elements and micro-alloying elements:		
9.1.1.5	Weld procedure qualifications for carbon steel in sour or wet hydrogen sulfide service to include cross-sectional micro-hardness testing?  Additional restrictions for the qualification test material:	Yes	No
9.3.4.1	Are tube-to-tubesheet joints to be seal-welded? Are tube-to-tubesheet joints to be strength-welded?	Yes Yes	No No
10.1.12	Is carbon steel plate in sour or wet hydrogen sulfide service subject to ultrasonic lamination checks?	Yes	No
10.2.6	Are special tests or additional requirements for drying or preservation required? Details:	Yes	No
10.3	Are shop run-in tests required? Details:	Yes	No
10.4	Is a performance test required?	Yes	No
11.1.4	Extent of skidding, boxing, crating, protection or coating for shipment:		
12.1	Supplemental requirements of Section 12 that apply:		

<b>AIR-COOLED HEAT EXCHANGER DATA SHEET (SI UNITS)</b>		Job No. _____	Item No. _____
		Page <u>1</u> of <u>2</u>	By _____
		Date _____	Revision _____
		Proposal No. _____	Contract No. _____
		Inquiry No. _____	Order No. _____
Manufacturer _____		Heat exchanged, kW _____	
Model No. _____		Surface/item-finned tube, m <sup>2</sup> _____	
Customer _____		Bare tube, m <sup>2</sup> _____	
Plant location _____		MTD, eff., °C _____	
Service _____		Transfer rate-finned, W/m <sup>2</sup> ·K _____	
Type draught <input type="radio"/> Induced <input type="radio"/> Forced		Bare tube, service, W/m <sup>2</sup> ·K _____	
Bay size (W × L), m _____	No. of bay/items _____	Clean, W/m <sup>2</sup> _____	
Basic design data			
Pressure design code _____		Structural code _____	
Tube bundle code stamped <input type="radio"/> Yes <input type="radio"/> No		Flammable service <input type="radio"/> Yes <input type="radio"/> No	
Heating coil code stamped <input type="radio"/> Yes <input type="radio"/> No		Lethal/toxic service <input type="radio"/> Yes <input type="radio"/> No	
Performance data — Tube side			
Fluid name _____		Temperature, °C	In      Out
Total fluid entering, kg/h _____		Total flow rate (liq./vap.), kg/h	____/____
Dew/bubble point, °C _____ / _____		Water/steam, kg/h	____/____
<input type="radio"/> Pour point <input type="radio"/> Freeze point, °C _____		Noncondensable, kg/h	____/____
Latent heat, kJ/kg _____		Relative molecular mass. (vap./non-cond.)	____/____
Inlet <input type="radio"/> kPa (ga) <input type="radio"/> kPa (abs) _____		Density (liq./vap.), kg/m <sup>3</sup>	____/____
pressure _____		Specific heat (liq./vap.), kJ/kg·K	____/____
Pressure drop (allow./calc.), kPa _____ / _____		Thermal conductivity (liq./vap.), W/m·K	____/____
Velocity (allow./calc.), m/s _____ / _____		Viscosity (liq./vap.), mPa·s	____/____
Inside foul res., m <sup>2</sup> ·K/W _____			
Performance data — Air side			
Air inlet temperature (design dry bulb), °C _____		Face velocity, m/s _____	
Air flow rate/item, (kg/h) (m <sup>3</sup> /h) _____		Min. design ambient temp., °C _____	
Mass velocity (net free area), kg/s·m <sup>2</sup> _____		Altitude, m _____	
Air outlet temperature, °C _____		Static pressure, kPa _____	
Air flowrate/fan, m <sup>3</sup> /h _____			
Design, materials and construction			
Design pressure, kPa (ga) _____		<b>Heating coil</b>	
Test pressure, kPa (ga) _____		No. of tubes _____ O.D., mm _____	
Design temperature, °C _____		Tube material _____	
Min. design metal temperature, °C _____		Fin material and type _____	
		Thickness, mm _____	
		Pressure design code _____	
<b>Tube bundle</b>		Stamp? <input type="radio"/> Yes <input type="radio"/> No	
Size (W × L), m _____		Heating fluid _____	Flow, kg/s _____
No./bay _____	No. of tube rows _____	Temperature (in/out), °C _____ / _____	
Bundles in parallel _____	In series _____	Inlet pressure, kPa (ga) _____	
Structure mounting <input type="radio"/> Grade <input type="radio"/> Pipe rack <input type="radio"/> Other		Pressure drop (allow./calc.), kPa _____ / _____	
Pipe-rack beams (distance C-C) _____		Design temp., °C, des. press., kPa (ga) _____ / _____	
Ladders, walkways, platforms <input type="radio"/> Yes <input type="radio"/> No		Inlet/outlet nozzle, DN _____ / _____	
Structure surf. prep./coating _____		<b>Header</b>	
Header surf. prep./coating _____		Type _____	
<b>Louver</b>		Material _____	
Material _____		Corr. allow., mm _____	
Action control: <input type="radio"/> Auto <input type="radio"/> Manual		No. of passes* _____	
Action type: <input type="radio"/> Opposed <input type="radio"/> Parallel			
* Give tube count of each pass if irregular.			

<b>AIR-COOLED HEAT EXCHANGER DATA SHEET (SI UNITS)</b>	Job No. _____ Item No. _____ Page <u>2 of 2</u> By _____ Date _____ Revision _____ Proposal No. _____ Contract No. _____ Inquiry No. _____ Order No. _____				
<b>Header (continued)</b> Slope, mm/m _____ Plug material _____ Gasket material _____ <table style="width:100%; border-collapse: collapse;"> <tr> <td style="width:10%;"><b>Nozzle</b></td> <td style="width:10%;">No.</td> <td style="width:15%;">Size, DN</td> <td style="width:75%;">Rating and facing</td> </tr> </table> Inlet _____ Outlet _____ Vent _____ Drain _____ Misc. conn's: TI _____ PI _____ Chemical cleaning _____ Min. wall thickness, mm _____ <b>Tube</b> Material _____ O.D., mm. _____ Min. wall thickness, mm. _____	<b>Nozzle</b>	No.	Size, DN	Rating and facing	No./bundle _____ Length, m _____ Pitch, mm _____ Layout _____ <b>Fin</b> Type _____ Material _____ Stock thickness, mm _____ Selection temperature, °C _____ O.D., mm. _____ No./m _____ Customer specification _____ _____ _____ _____
<b>Nozzle</b>	No.	Size, DN	Rating and facing		
<b>Mechanical equipment</b>					
<b>Fan</b> Manufacturer & model _____ No./bay _____ Speed, r/min _____ Diameter, m _____ No. of blades _____ Angle _____ Pitch adjustment: <input type="radio"/> Manual <input type="radio"/> Auto Blade material _____ Hub material _____ kW/fan.@des.temp. _____ @min.amb. _____ Max. allow./calc.tip speed, m/s _____ / _____  <b>Driver</b> Type _____ Manufacturer & model _____ No./bay _____ Driver kW _____	Speed, r/min _____ Service factor _____ Enclosure _____ Volt _____ Phase _____ Cycle _____ Fan noise level (allow./calc.), dB(A), @m _____ / _____  <b>Speed reducer</b> Type _____ Manufacturer & model _____ No./bay _____ Service factor _____ Speed ratio _____/1 Support: <input type="radio"/> Structure <input type="radio"/> Pedestal Vib. switch: <input type="radio"/> Yes <input type="radio"/> No Enclosure _____				
<b>Controls air-side</b>					
<b>Air recirculation:</b> <input type="radio"/> None <input type="radio"/> Internal <input type="radio"/> External Over: <input type="radio"/> Side <input type="radio"/> End Degree control of outlet process temp. (max. cooling), +/- °C _____ / _____ Action on control signal failure _____ Fan pitch: <input type="radio"/> Minimum <input type="radio"/> Maximum <input type="radio"/> Lockup Louvers: <input type="radio"/> Open <input type="radio"/> Close <input type="radio"/> Lockup Actuator air supply _____ Fan: <input type="radio"/> None <input type="radio"/> Positioner <input type="radio"/> Bias relay	<b>Louvers:</b> <input type="radio"/> Inlet <input type="radio"/> Outlet <input type="radio"/> Bypass Positioner: <input type="radio"/> Yes <input type="radio"/> No Signal air pressure, kPa (ga) From _____ To _____ From _____ To _____ Supply air pressure, kPa (ga) Max. _____ Min. _____ Max. _____ Min. _____				
<b>Shipping</b>					
Plot area (W × L), m _____ Bundle mass, kg _____ Bay _____	Total _____ Shipping, kg _____				



<b>AIR-COOLED HEAT EXCHANGER DATA SHEET (US CUSTOMARY UNITS)</b>		Job No. _____	Item No. _____
		Page <u>1 of 2</u>	By _____
		Date _____	Revision _____
		Proposal No. _____	Contract No. _____
		Inquiry No. _____	Order No. _____
Manufacturer _____	Model No. _____	Customer _____	Plant location _____
Service _____	Type draught <input type="radio"/> Induced <input type="radio"/> Forced	Bay size (W × L), ft _____	No. of bay/items _____
Heat exchanged, Btu/h _____		Surface/item-finned tube, ft <sup>2</sup> _____	
Bare tube, ft <sup>2</sup> _____		MTD, eff., °F _____	
Transfer rate-finned, Btu/(h·ft <sup>2</sup> ·°F) _____		Bare tube, service, Btu/(h·ft <sup>2</sup> ·°F) _____	
Clean, Btu/h·ft <sup>2</sup> ·°F _____			
<b>Basic design data</b>			
Pressure design code _____		Structural code _____	
Tube bundle code stamped <input type="radio"/> Yes <input type="radio"/> No		Flammable service <input type="radio"/> Yes <input type="radio"/> No	
Heating coil code stamped <input type="radio"/> Yes <input type="radio"/> No		Lethal/toxic service <input type="radio"/> Yes <input type="radio"/> No	
<b>Performance data — tube side</b>			
Fluid name _____		In      Out	
Total fluid entering, lb/h _____		Temperature, °F _____	
Dew/bubble point, °F _____ / _____		Total flow rate (liq./vap.), lb/h _____ / _____	
<input type="radio"/> Pour point <input type="radio"/> Freeze point, °F _____		Water/steam, lb/h _____ / _____	
Latent heat, Btu/lb _____		Noncondensable, lb/h _____ / _____	
Inlet pressure <input type="radio"/> psig <input type="radio"/> psia _____		Rel molecular mass (vap./non-cond.) _____ / _____	
Pressure drop (allow./calc.), psi _____ / _____		Density (liq./vap.), lb/ft <sup>3</sup> _____ / _____	
Velocity (allow./calc.), ft/s _____ / _____		Specific heat (liq./vap.), Btu/lb·°F _____ / _____	
Inside foul res., h·ft <sup>2</sup> ·°F/Btu _____		Thermal conductivity (liq./vap.), Btu/(h·ft·°F) _____ / _____	
		Viscosity (liq./vap.), cP _____ / _____	
<b>Performance data — air side</b>			
Air inlet temperature (design dry-bulb), °F _____		Face velocity, sfpm _____	
Air flowrate/item, (lb/h) (scfm) _____		Min. design ambient temp., °F _____	
Mass velocity (net free area), lb/h·ft <sup>2</sup> _____		Altitude, ft _____	
Air outlet temperature, °F _____		Static pressure, inches water _____	
Air flowrate/fan, acfm _____			
<b>Design, materials and construction</b>			
Design pressure, psig _____		<b>Heating coil</b>	
Test pressure, psig _____		No. of tubes _____ O.D., in. _____	
Design temperature, °F _____		Tube material _____	
Min. design metal temperature, °F _____		Fin material and type _____	
		Thickness, in. _____	
<b>Tube bundle</b>		Pressure design code _____	
Size (W × L), ft _____		Stamp? <input type="radio"/> Yes <input type="radio"/> No	
No./bay _____ No. of tube rows _____		Heating fluid _____ Flow, lb/h _____	
Bundles in parallel _____ In series _____		Temperature (in/out), °F _____ / _____	
Structure mounting <input type="radio"/> Grade <input type="radio"/> Pipe rack <input type="radio"/> Other		Inlet pressure, psig _____	
Pipe-rack beams (distance C-C) _____		Pressure drop (allow./calc.), psi _____ / _____	
Ladders, walkways, platforms <input type="radio"/> Yes <input type="radio"/> No		Design temp., °F, des. press., psig _____ / _____	
Structure surf. prep./coating _____		Inlet/outlet nozzle, nps _____ / _____	
Header surf. prep./coating _____		<b>Header</b>	
<b>Louver</b>		Type _____	
Material _____		Material _____	
Action control: <input type="radio"/> Auto <input type="radio"/> Manual		Corrosion allow., in. _____	
Action type: <input type="radio"/> Opposed <input type="radio"/> Parallel		No. of passes* _____	
* Give tube count of each pass if irregular.			

<b>AIR-COOLED HEAT EXCHANGER DATA SHEET (US CUSTOMARY UNITS)</b>				Job No. _____	Item No. _____
<b>Header (continued)</b>				Page <u>2 of 2</u>	By _____
Slope, in./ft _____				Date _____	Revision _____
Plug material _____				Proposal No. _____	Contract No. _____
Gasket material _____				Inquiry No. _____	Order No. _____
<b>Nozzle</b>	No. _____	Size, NPS _____	Rating and facing _____	No./bundle _____	Length, ft _____
Inlet	_____	_____	_____	Pitch, in. _____	
Outlet	_____	_____	_____	Layout _____	
Vent	_____	_____	_____	<b>Fin</b>	
Drain	_____	_____	_____	Type _____	
Misc. conn's: TI _____		PI _____		Material _____	
Chemical cleaning _____				Stock thickness, in. _____	
Min. wall thickness, in. _____				Selection temperature, °F _____	
<b>Tube</b>				O.D., in. _____	No./in. _____
Material _____				Customer specification _____	
O.D., in. _____		Min. wall thickness, in. _____		_____	_____
				_____	_____
				_____	_____
				_____	_____
				_____	_____
				_____	_____
				_____	_____
<b>Mechanical equipment</b>					
<b>Fan</b>			Speed, r/min _____	Service factor _____	
Manufacturer and model _____			Enclosure _____		
No./bay _____	Speed, rpm _____				
Diameter, ft _____	No. of blades _____				
Angle _____			Fan noise level (allow./calc.), dB(A), @ft _____/_____		
Pitch adjustment: <input type="radio"/> Manual <input type="radio"/> Auto			<b>Speed reducer</b>		
Blade material _____	Hub material _____		Type _____		
kW/fan.@des.temp. _____	@min.amb. _____		Manufacturer & model _____		
Max. allow./calc.tip speed, fpm _____/_____			No./bay _____	Service factor _____	
<b>Driver</b>			Speed ratio _____/1		
Type _____			Support: <input type="radio"/> Structure <input type="radio"/> Pedestal		
Manufacturer and model _____			Vib. switch: <input type="radio"/> Yes <input type="radio"/> No		
No./bay _____	Driver hp _____		Enclosure _____		
<b>Controls air-side</b>					
<b>Air recirculation:</b> <input type="radio"/> None <input type="radio"/> Internal <input type="radio"/> External			<b>Louvers:</b> <input type="radio"/> Inlet <input type="radio"/> Outlet <input type="radio"/> Bypass		
Over: <input type="radio"/> Side <input type="radio"/> End			Positioner: <input type="radio"/> Yes <input type="radio"/> No		
Degree control of outlet process temp.			Signal air pressure, psig		
(max. cooling), +/- °F _____/_____			From _____ To _____		
Action on control signal failure _____			From _____ To _____		
Fan pitch: <input type="radio"/> Minimum <input type="radio"/> Maximum <input type="radio"/> Lockup			Supply air pressure, psig		
Louvers: <input type="radio"/> Open <input type="radio"/> Close <input type="radio"/> Lockup			Max. _____ Min. _____		
Actuator air supply _____			Max. _____ Min. _____		
Fan: <input type="radio"/> None <input type="radio"/> Positioner <input type="radio"/> Bias relay					
<b>Shipping</b>					
Plot area (W x L), ft _____			Total _____		
Bundle mass, lb _____			Shipping, lb _____		
Bay _____					



<b>AIR-COOLED HEAT EXCHANGER NOISE DATA SHEET</b>	Job No. _____	Item No. _____
	Page: <u>  1  </u> of <u>  1  </u>	By _____
	Date _____	Revision _____
	Proposal No. _____	Contract No. _____
	Inquiry No. _____	Order No. _____

1	Noise data	Purchaser specification	Purchaser specification	Vendor guarantee	Vendor guarantee
2	Octave bands center	$L_p$ at designated location	$L_W$ per fan	$L_p$ at designated location	$L_W$ per fan
3	63				
4	125				
5	250				
6	500				
7	1000				
8	2000				
9	4000				
10	8000				
11	dB(A)				
12	Overall unit $L_W$				
13	dB(A)				
14	<p>Unless otherwise specified:</p> <p><math>L_p</math> is the sound-pressure level measured in dB, reference <math>2 \times 10^{-5}</math> N/m<sup>2</sup>.</p> <p><math>L_W</math> is the sound-power level measured in dB, reference <math>1 \times 10^{-12}</math> W.</p> <p>For forced-draught fans, the <math>L_p</math> is measured at the centerline of the fan 1 m below the inlet of the fan.</p> <p>For induced-draught fans, the <math>L_p</math> is measured 1 m below the bundles.</p> <p>Noise of equipment shall include noise from speed reducer and motor.</p> <p>The upper tolerance for noise levels is 0 dB(A).</p> <p>Tonal noise is defined as having a single octave band equal to more than 6 dB above the adjacent bands.</p> <p>If tonal noise is present, then the specified overall noise levels shall be interpreted as 5 dB(A) more stringent.</p>				
15	Description of designated location:				
16	Specification of special requirements (with/without acoustic measures, special low-noise fans):				
17					
18					
19					
20					

## **Annex C** (informative)

### **Winterization of Air-cooled Heat Exchangers**

#### **C.1 Scope**

This annex presents design features and other considerations that contribute to satisfactory functioning of air-cooled heat exchangers operating with low-temperature inlet air. Data related to structural materials for low-temperature service and safety precautions related to the accumulation of snow and ice are not included.

#### **C.2 Winterization Problem Areas**

##### **C.2.1 General**

The purposes of C.2 are as follows:

- a) to identify reasons for winterization of air-cooled heat exchangers;
- b) to outline general design data requirements for winterization and guidelines for supplying such data;
- c) to review heat losses and general problem areas;
- d) to establish process categories that can require winterization and safety margins for each category.

##### **C.2.2 Reasons for Winterization**

Winterization is generally applied to maintain the tube-wall temperature at or above a specified minimum tube-wall temperature to prevent operating problems. The specified minimum tube-wall temperature is the point at which the tube-wall temperature approaches the fluid's critical process temperature. Critical process temperatures include the freezing point, pour point, wax point, dew point (if condensation causes corrosion), hydrate formation point and any other temperature at which operating difficulties can occur.

In cold climates, where the ambient temperature can vary from  $-29\text{ }^{\circ}\text{C}$  ( $-20\text{ }^{\circ}\text{F}$ ) or lower during winter months to  $30\text{ }^{\circ}\text{C}$  ( $86\text{ }^{\circ}\text{F}$ ) or higher during summer months, airflow control alone can be inadequate to provide control of the process outlet temperature and the tube wall temperature. In such cases, winterization can also be required as a means of providing process control.

##### **C.2.3 General Design Data Requirements**

The Purchaser should specify the following:

- a) minimum tube-wall temperature, which should include a safety margin as discussed in C.2.7;
- b) minimum design air temperature;
- c) all alternative process conditions, including reduced flow (turndown) operations;
- d) design wind velocity and the prevailing wind direction;

- e) availability of steam or another source of heat for start-up in cold weather. (If steam is available, the steam pressure should be specified.)

#### **C.2.4 Heat Losses**

The effect of heat losses (by conduction and convection, louver leakage and natural draught) on the tube-wall temperature during start-up, shutdown and standby operating conditions should be considered when the requirements for a heating coil are determined.

#### **C.2.5 General Problem Areas**

The exit fluid temperature for any single row of any given pass might not be the same as the average exit fluid temperature for that pass. To avoid potential problems in the field, the exit fluid temperature for each row should be calculated separately to determine the lowest tube-wall temperature.

For critical services, it can be desirable to monitor the tube-wall temperature in the coldest zone. This may be done by installing thermocouples at critical points.

Mal-distribution of the process fluid or airstream can also cause problems that should be considered in the design of the equipment.

#### **C.2.6 Process Categories**

##### **C.2.6.1 General**

Most winterization problems fall into one of the following six categories:

- a) problems with water and dilute aqueous solutions;
- b) problems with total steam condensers;
- c) problems with partial steam condensers;
- d) problems with condensing process fluids containing steam, with or without noncondensables;
- e) problems with viscous fluids and fluids with high pour points;
- f) problems resulting from freezing, hydrate formation, and corrosion caused by condensate.

These categories and the ways in which they apply to typical operating cases are described in C.2.6.2 through C.2.6.7.

##### **C.2.6.2 Category 1 — Water and Dilute Aqueous Solutions**

Water and dilute aqueous solutions have high tube-side heat transfer coefficients, resulting in relatively high tube-metal temperatures. When these fluids are present, simple winterization systems, such as airflow control systems, are indicated. In cold climates, where the ambient temperature can be  $-29\text{ }^{\circ}\text{C}$  ( $-20\text{ }^{\circ}\text{F}$ ) or lower during winter months, airflow control alone can be inadequate as a means of providing protection against freezing. In such case, more elaborate winterization schemes should be considered. Start-up and shutdown at extremely low temperatures can require additional measures.

### C.2.6.3 Category 2 — Total Steam Condensers

Total steam condensers that are single pass can be subject to a backflow of steam from the outlet end of the upper (hotter) tube rows into the outlet end of the lower (colder) tube rows. This usually leads to noncondensable contaminants collecting near the outlet end of the colder tubes. The presence of noncondensables results in diminished performance and in subcooling and possible freezing of condensate in the colder tubes. Corrosion can also occur.

In quite a few installations, a particular set of conditions has caused rapid perforation of tube walls. The perforations occur near the exit end of the lower (colder) tube rows. When this happens, a repetitive knocking or clicking noise, called water hammer, is always present. These failures, which have occurred in numerous locations, have the following common characteristics:

- a) one pass with four or more rows of tubes with an outside diameter of 25.4 mm (1 in.) and length of 11 m to 16 m (36 ft to 52 ft);
- b) inlet steam pressure between 0 kPa and 170 kPa gauge (0 psig and 25 psig).

The perforations have occurred as quickly as within one day of service on tubes with a wall thickness of 0.89 mm (0.035 in.) and as slowly as three months on tubes with a wall thickness of 2.11 mm (0.083 in.). It appears that the rapidity of failure appears is related to the severity of the water hammer.

Measures to prevent this type of failure are all aimed at reducing or eliminating the quantity of steam back-flowing into the colder tubes. For instance, in a four-row, one-pass condenser, limiting the tube length to 360 times the tube outside diameter seems to suffice [for example, a length of 9 m (30 ft) for tubes with an outside diameter of 25.4 mm (1 in.)]. Alternatively, the rear header can be separated into four non-communicating compartments with drains provided for each compartment. Another method is to use restriction orifices in the tube inlets; however, this measure might not be completely effective at all flow-rates.

### C.2.6.4 Category 3 — Partial Steam Condensers

In category 3 process streams, the quantity of outlet vapor is large enough that backflow cannot occur and steam exits continuously from the outlet ends of all tube rows. The quantity of outlet vapor is typically 10 % to 30 % by mass of the total inlet flow. Outlet quantities below 10 % by mass are characteristic of category 2 condensers. The exact quantity of outlet vapor should be established by calculation, with consideration given to the mode of operation at the minimum ambient temperature. If calculations show that backflow does not occur, simple winterization systems, such as airflow control, are indicated. If calculations indicate that backflow does occur, moderate to extensive protection systems can be indicated.

### C.2.6.5 Category 4 — Condensing Process Fluids Containing Steam with or without Noncondensables

Category 4 is an extension of category 3. Category 4 highlights the effects of other condensables on the tube-wall temperature. Prediction of the tube-side flow regimen is essential for an accurate evaluation of tube-wall and fluid temperatures. Consider, for example, a stream containing steam, condensable hydrocarbons and non-condensables. Annular flow can exist at the condenser inlet, with a liquid hydrocarbon annulus being formed on the cold tube wall and surrounding a gas core. Stratified flow can exist at the condenser outlet, with water and liquid hydrocarbons draining from the bottom of the tube while steam condenses on the upper portion. Simple winterization systems are usually indicated when these conditions are present. In cold climates, where the ambient temperature can be  $-29^{\circ}\text{C}$  ( $-20^{\circ}\text{F}$ ) or lower during winter months, airflow control alone has proven to be unreliable as a means of providing protection against freezing. In such case, more elaborate winterization schemes should be considered.

### C.2.6.6 Category 5 — Viscous Fluids and Fluids with High Pour Points

When a viscous fluid is flowing through a number of parallel paths, local variations in cooling can cause a drastic reduction in velocity in some of the flow paths. This phenomenon is called “unstable flow”. Unstable flow is caused when, under certain conditions of bulk viscosity, wall viscosity and pressure drop, the increase in pressure drop resulting from a higher viscosity (caused by the additional cooling allowed by a lower velocity) offsets the decrease in pressure drop resulting from the lower velocity. This can occur only when the fluid is in laminar flow.

When unstable flow occurs, the velocities in parallel tubes within a pass can differ by as much as 5:1. As a result, the exchanger's overall tube-side pressure drop can increase by up to 100 % and the heat removal can decrease to less than 50 % of that possible if the fluid were equally distributed among the tube paths. This flow mal-distribution is a major factor in many cases of diminished performance of viscous and high-pour-point fluid coolers.

Viscous liquids are one of the more difficult fluids to adequately design for, and this difficulty increases as the ambient temperature decreases.

At present, only general guidelines exist for avoiding such mal-distribution. These guidelines are as follows.

- a) The bulk viscosity of the process fluid at the outlet temperature should not exceed 50 mPa·s (50 cP).
- b) The ratio of wall viscosity to bulk viscosity should not exceed 3:1.

The following additional factors should be given extra emphasis in both design and fabrication for this type of service.

- Air-side flow distribution and temperature distribution should be as uniform as possible. External recirculation over only one side can cause non-uniform airflow and uneven air temperature at the bundle. Over the end recirculation or recirculation over both sides should, therefore, be considered.
- Air bypassing the bundle between the side frames and tubes should be minimized by conforming to a maximum gap of 10 mm ( $\frac{3}{8}$  in.) as specified in 7.1.1.8.
- Allowable process fluid pressure drop should be high. Pressure drops of 275 kPa (40 psi) or higher are common. The tube diameter and velocity should be established to avoid laminar flow where possible. Since such designs tend to be controlled by the low tube side heat transfer coefficient, utilizing higher pressure drop and higher velocity normally results in an appreciable reduction in required surface area, offsetting the cost of a larger pump.
- Tube-side flow should be uniformly distributed within the headers. This can require additional nozzles and/or external insulation of the headers.
- Where laminar flow cannot be avoided, tube inserts should be considered (with the Purchaser's approval), to increase turbulence, at the expense of additional pressure drop.

There can be cases in which successful operation can be achieved while violating these guidelines. However, when successful experience is lacking, it is risky to ignore these recommendations. Alternative designs that should be considered include indirect systems and air-cooled heat exchangers with serpentine coils.

### C.2.6.7 Category 6 — Freezing Point, Hydrate Formation Point, and Dew Point

Category 6 process streams are characterized by a discrete critical process temperature. For such streams, the calculation of wall and fluid temperatures tends to be straightforward. Depending on design conditions, recommended winterization systems include the full range outlined in C.3.

### C.2.7 Safety Margins

So many variables are involved in the process streams described in C.2.6.2 through C.2.6.7 that establishing a fixed safety margin (the tube-wall temperature minus the critical process temperature) is difficult. Each problem should be analyzed on an individual basis.

In the absence of more specific information, the safety margins given in Table C.1 should be added to the critical process temperature to determine the specified minimum tube-wall temperature.

**Table C.1 — Safety Margins for Different Process Categories**

Category	Safety Margin °C (°F)
1	8.5 (15)
2	8.5 (15)
3	8.5 (15)
4	8.5 (15)
5	14 (25)
6	11 (20)
NOTE See C.2.6 for description of categories.	

## C.3 Methods of Winterization

### C.3.1 Airflow and Air Temperature Control Systems

#### C.3.1.1 System A — Airflow Control

**C.3.1.1.1** System A generally uses variable speed drives or automatically controlled variable-pitch fans, as shown in Figure C.1, and/or automatically or manually controlled louvers, as shown in Figure C.2, to control airflow.

**C.3.1.1.2** Variable speed drives and automatically controlled variable-pitch fans offer the following advantages over louvers:

- better airflow control, providing more sensitive control of process temperatures at or near design conditions;
- lower power requirements at reduced ambient temperatures.

**C.3.1.1.3** Automatically controlled variable-pitch fans have the following disadvantages:

- less precise airflow control when the required airflow is less than 30 % of the full airflow;
- more sensitivity to wind effects at lower airflows.

**C.3.1.1.4** Louvers offer the following advantages over automatically controlled variable-pitch fans:

- more precise airflow control when the required airflow is less than 30 % of the full airflow;
- less sensitivity to wind effects;

- capability of full closure for warming the unit at start-up and shutdown.

#### **C.3.1.1.5** Louvers have the following disadvantages:

- less precise control when the required airflow is more than 30 % of the full airflow, since louvers have non-linear control characteristics;
- potentially inoperable linkages as a result of ice, snow, corrosion or wear.

Airflow control is used primarily to control process temperatures and offers the least winterization protection.

Variable speed drives have become much more prevalent in recent years, especially in cold climates where there is a significant variation in ambient air temperature between summer and winter months. The incorporation of variable speed drives provides substantial improvements in the areas of process control, electric power reduction and noise reduction. The power and noise reductions with fan speed are substantial, since power is proportional to fan speed to the 3rd power, and noise is proportional to fan speed to the 5th power.

Fan efficiency varies with blade pitch angle and reaches a maximum at an optimum angle, decreasing beyond that. Increasing blade pitch angle beyond the stall point actually causes a decrease in airflow. Increased fan speed, on the other hand, results in an increase in airflow since airflow is directly proportional to the revolutions per minute, RPM (speed) of the fan.

Louvers should always be used in combination with variable speed drives when the airflow requirement for any operating case is less than 20 % of the required design airflow.

#### **C.3.1.2 System B — Airflow Control Plus Air Temperature Control Using a Noncontained Internal Recirculation System**

In system B, the automatically controlled variable-pitch fan near the process outlet reverses airflow when the inlet air temperature is low. The air heated from flow over the tubes enters a zone beneath the tube bundle that is protected to some degree from wind effects by downward-projecting wind skirts. Part of the heated air is then mixed with inlet air as shown in Figure C.3 and Figure C.4. This system can be subject to uneven air mixing below the tube bundle and does not provide a positive method of controlling the mixed air inlet temperature. In addition, wind can adversely affect the circulation of the hot air. Care should be taken in selecting mechanical equipment installed below the downflow fan because of the higher air temperature. This system is not generally recommended, but has been used for heat exchangers requiring moderate winterization protection.

#### **C.3.1.3 System C — Airflow Control Plus Air Temperature Control Using a Contained Internal Recirculation System**

In system C, the automatically controlled variable-pitch fan near the process outlet reverses when the inlet air temperature is low to direct airflow downward while the exhaust louvers partially close, as shown in Figure C.5. Simultaneously, the vertical bypass louvers above the tube bundle open to redirect part of the exhaust air along the length of the tube bundle. This air is mixed above the downdraught side of the tube bundle with incoming ambient air. Only enough air is directed through the bypass louvers to ensure that the mixed air temperature above the downdraught fan is above a preset level. For certain design cases, wind skirts can be required below the tube bundle. The disadvantage of this system is that areas of the bundle can be exposed to low air temperatures as a result of uneven air mixing. Care should be taken in selecting mechanical equipment installed on and below the downflow fan because of the higher air temperature. This system offers an additional degree of winterization protection, compared with the systems described in C.3.1.1 and C.3.1.2.

### **C.3.1.4 System D — Airflow Control Plus Air Temperature Control Using an External Recirculation System**

In system D, hot exhaust air is recirculated through an external recirculation duct being mixed with inlet air when the inlet air temperature is low. The amount of air recirculated and the temperature of the mixed stream are controlled by partially closing the exhaust louvers while modulating the inlet and bypass louvers. This system normally includes a floor so that the unit is completely enclosed, thus providing positive control of the entering airflow. Although the temperature of the process fluid can be controlled by louver action alone, this is not recommended. Variable speed drives or automatically controlled variable-pitch fans should be used to control the process temperature more precisely. Variable speed drives or automatically controlled variable-pitch fans can also enable the user to reduce the fan power required at lower ambient temperatures.

Figure C.6 illustrates recirculation over both sides of the unit. Some units may have a recirculation duct over one side only. Alternatively, a recirculation duct may be placed at one or both ends of the unit to minimize the width of the bay or to provide an enclosed heated area for headers and header walkways. In addition, various combinations and locations of inlet louvers can be used to maximize mixing of hot and cold airstreams.

This system provides maximum winterization protection, compared with the systems described in C.3.1.1 through C.3.1.3, and can operate in ambient temperatures lower than any previous design discussed. For this reason, it is generally the most suitable in cold climates where the ambient temperature is below  $-29\text{ }^{\circ}\text{C}$  ( $-20\text{ }^{\circ}\text{F}$ ), providing the highest degree of plenum temperature control and process temperature control. Since it can be totally enclosed by closing the inlet and exit louvers, it provides more effective protection during start-up and shutdown situations during cold weather.

Recirculation over one side is generally suitable for most applications and bundle sizes. When applied, the recirculation duct should always be placed on the prevailing, windward side of the tube bundle for protection. It should be noted, however, that ideal mixing of the warm recirculation air and the colder inlet air is never fully achieved. Propeller type fans are not mixing devices. Unless provision is made in recirculation systems for mixing of cold inlet air and warm recirculation air, the temperature of the mixed air stream is not uniform and can vary significantly from one part of the plenum to another.

### **C.3.1.5 Recirculation Ducts — Arrangement and Location**

#### **C.3.1.5.1 Multi-bay Units**

For units with non-symmetrical piping manifolds (typically single-phase gas or liquid cooling service), recirculation over one side should be considered adequate in the majority of cases.

For units with symmetrical piping manifolds (typically with two-phase flow conditions at the inlet and/or outlet, and an even number of bays), recirculation over one side may be used, however the ducts should be located on the outer sides of each pair of bays (i.e. a mirror arrangement), to provide uniform distribution of recirculation air to each bundle. A full partition wall and door should be provided between each pair of bays. Recirculation over both sides may also be provided.

#### **C.3.1.5.2 Single Bay Units**

Recirculation over one side only may be used when the unit is located adjacent to or within a bank of other units.

For units where both sides can be exposed to ambient wind conditions, recirculation over both sides should be considered.

#### **C.3.1.5.3 Special Services (Single or Multi-bay Units)**

For services with viscosity exceeding 10 cP at the process outlet temperature or for services with a high pour point, recirculation over both sides should be provided.

For vacuum system condensers located in freezing climates, recirculation over both sides should be provided. Alternately, recirculation over the end may be applied.

In arctic climates (ambient temperatures of  $-45\text{ }^{\circ}\text{C}$  [ $-50\text{ }^{\circ}\text{F}$ ] and lower), recirculation over both sides is strongly advised. In addition, recirculation over the ends can be necessary to protect the header boxes.

All fans should be equipped with variable speed drives or auto-variable pitch for external over the side recirculation to avoid mal-distribution of the recirculation air, especially for units with process turndown rates at 50 % of design or lower. For over-the-end recirculation, the fans at the outlet end of the bundle only may be equipped with variable speed drives or auto-variable pitch. The variable-pitch or variable speed fan should always be located on the outlet (coldest) end of the process bundle to maximize tube wall temperatures at the coldest section of the tube bundle. When a variable speed drive system is used, the minimum allowable fan speed should not be less than 30 % in order to ensure that there is adequate driving force for air recirculation.

If multiple units (services) are arranged adjacent to each other in banks, each unit (service) should be separated by a full partition wall, with a suitable access door. Full partition walls between bays in the same service should be considered for multi-bay units where uniform distribution of the re-circulation air is critical (e.g. condensers, viscous coolers). The number and location of partition walls should be agreed between the Purchaser and the Vendor.

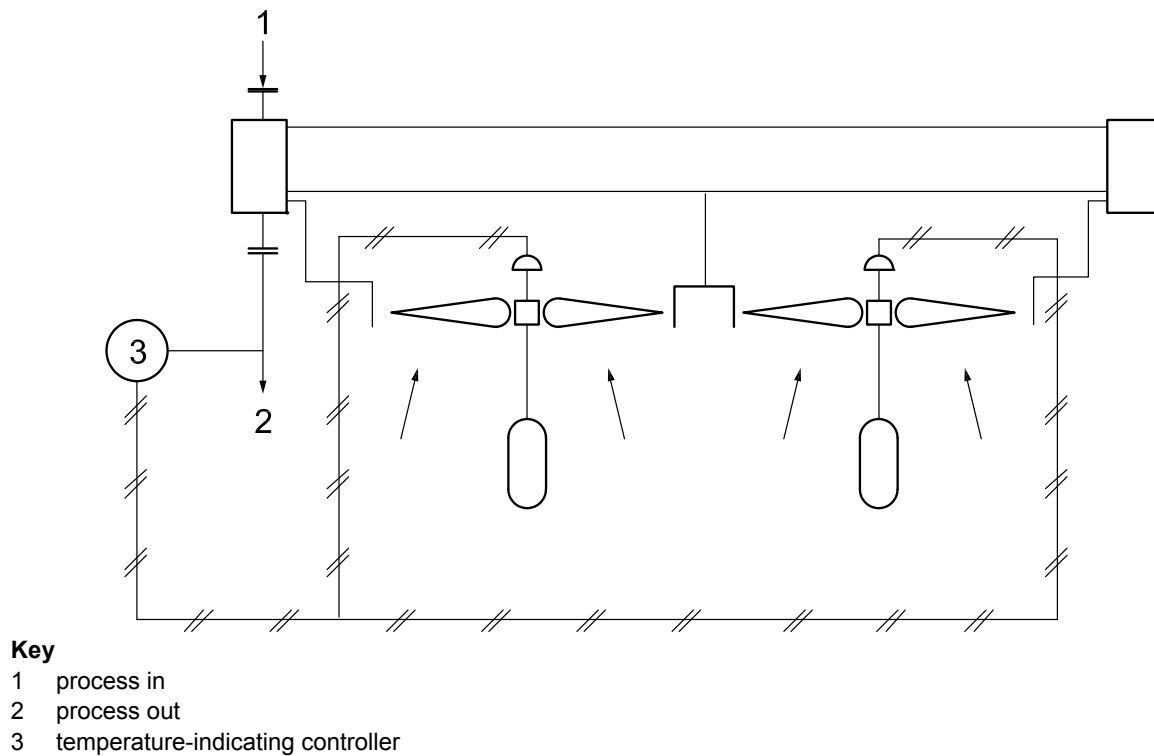

NOTE The air-cooled heat exchanger can be of the forced- or induced-draught type.

**Figure C.1 — System A — Airflow Control with Variable Speed Drives or Automatically Controlled Variable-pitch Fans**

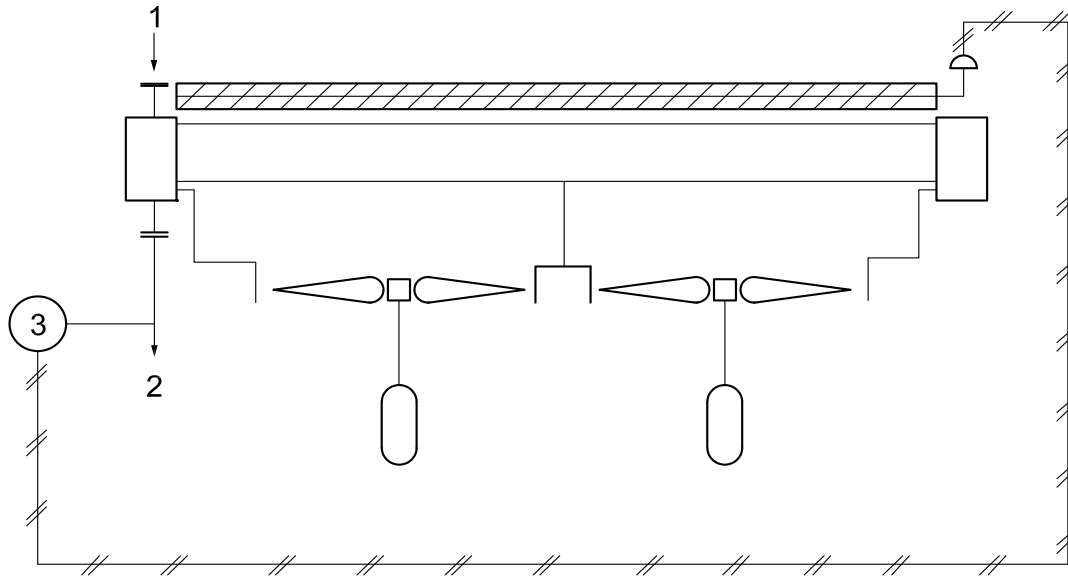

**Key**

- 1 process in
- 2 process out
- 3 temperature-indicating controller

NOTE The air-cooled heat exchanger can be of the forced- or induced-draught type.

**Figure C.2 — System A — Airflow Control with Automatically Controlled Outlet Louvers and Fixed-pitch Fans**

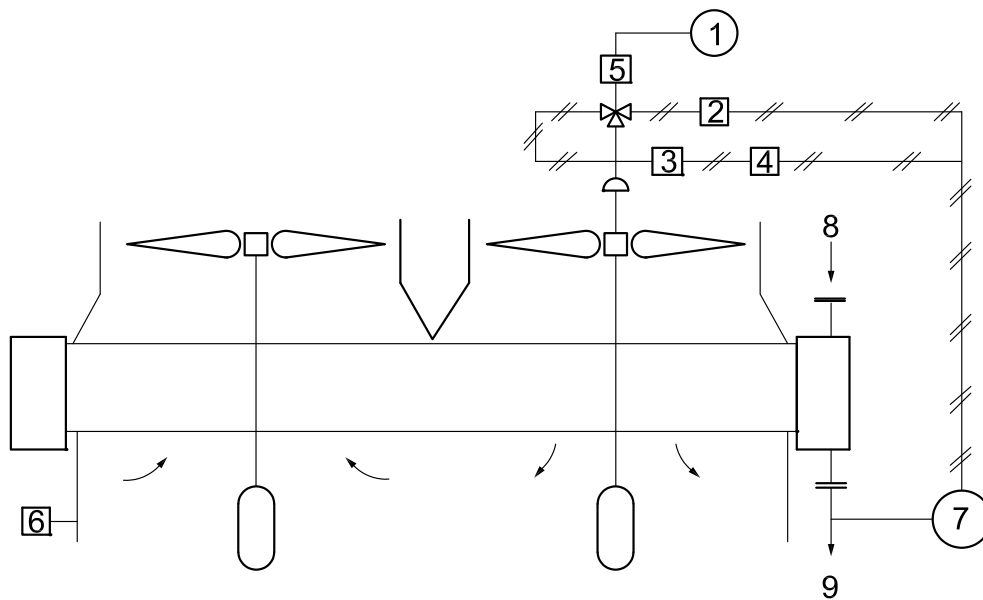

**Key**

- |                                  |                                     |
|----------------------------------|-------------------------------------|
| 1 ambient air temperature switch | 6 wind skirt                        |
| 2 high-limit relay               | 7 temperature-indicating controller |
| 3 reversing relay                | 8 process in                        |
| 4 low-limit relay                | 9 process out                       |
| 5 three-way solenoid switch      |                                     |

NOTE All fans can be of the automatically controlled variable-pitch type.

**Figure C.3 — System B — Induced Draught with Non-contained Internal Air Recirculation**

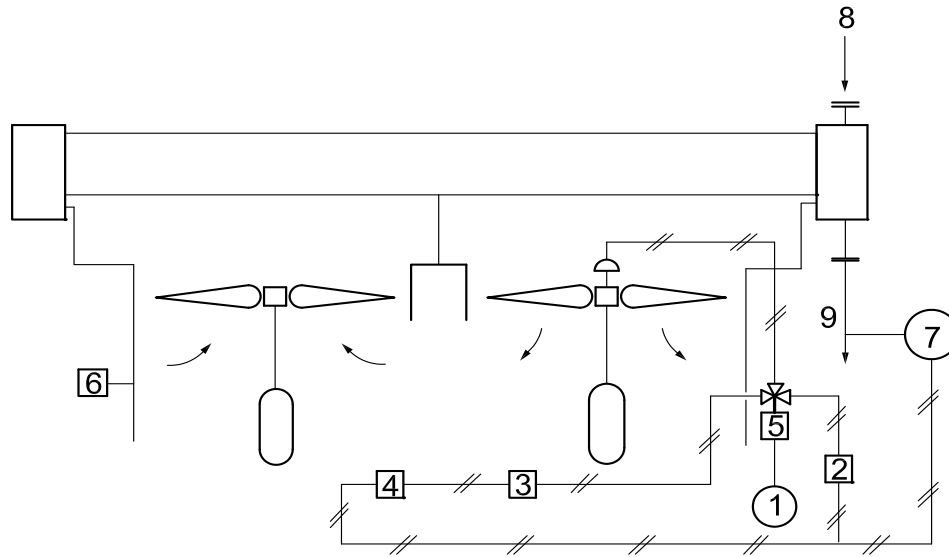
**Key**

- |                                  |                                     |
|----------------------------------|-------------------------------------|
| 1 ambient air temperature switch | 6 wind skirt                        |
| 2 high-limit relay               | 7 temperature-indicating controller |
| 3 reversing relay                | 8 process in                        |
| 4 low-limit relay                | 9 process out                       |
| 5 three-way solenoid switch      |                                     |

NOTE All fans can be of the automatically controlled variable-pitch type.

**Figure C.4 — System B — Forced Draught with Non-contained Internal Air Recirculation**

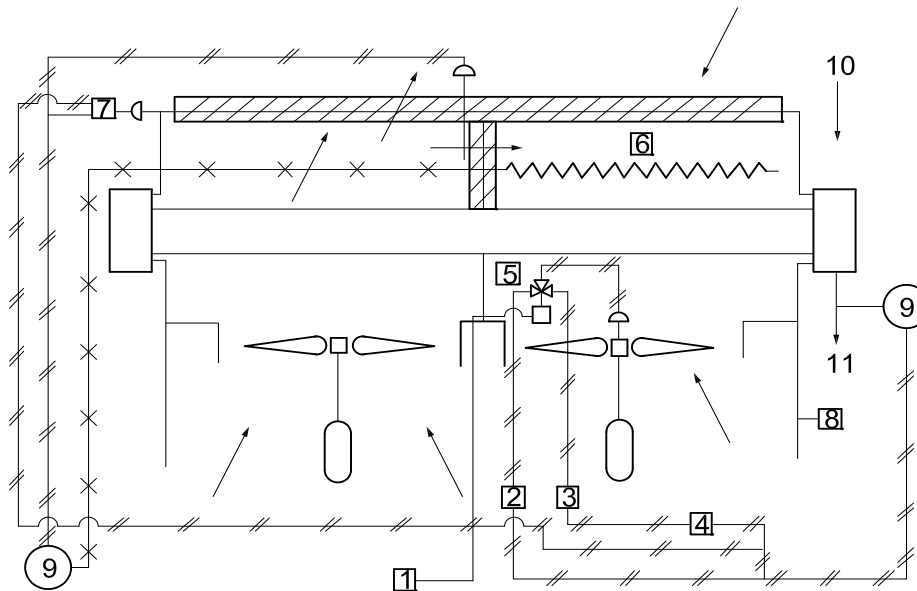
**Key**

- |                                      |                                     |
|--------------------------------------|-------------------------------------|
| 1 ambient air temperature switch     | 7 low- or high-pressure selector    |
| 2 high-limit relay                   | 8 wind skirt (optional)             |
| 3 reversing relay                    | 9 temperature-indicating controller |
| 4 low-limit relay                    | 10 process in                       |
| 5 three-way solenoid switch          | 11 process out                      |
| 6 temperature-sensing capillary tube |                                     |

**Figure C.5 — System C — Typical Forced-draught Air-cooled Heat Exchanger with Contained Internal Air Recirculation**

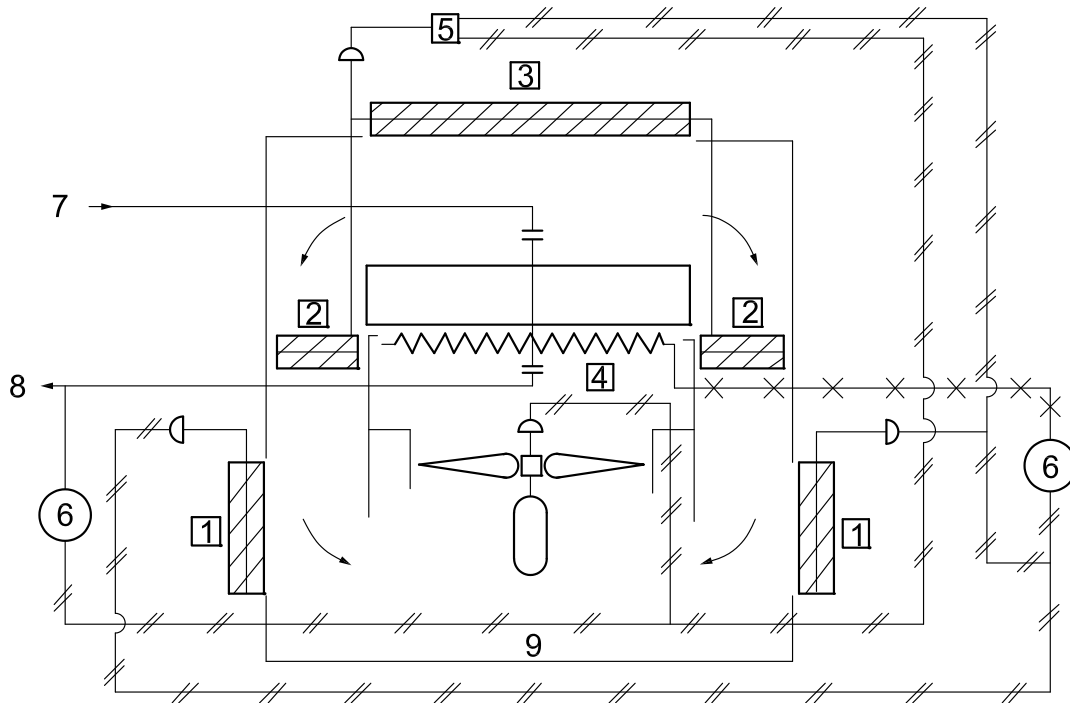

**Key**

- |   |                                     |
|---|-------------------------------------|
| 1 intake louvers                        | 6 temperature-indicating controller |
| 2 bypass louver                         | 7 process in                        |
| 3 exhaust louvers                       | 8 process out                       |
| 4 temperature-sensing capillary tube    | 9 floor plate or grade              |
| 5 low- or high-pressure selector switch |                                     |

50 % to 100 % of the fans should be of the variable speed type or automatically controlled variable-pitch type.

**Figure C.6 — System D — Typical Forced-draught Air-cooled Heat Exchanger with External Air Recirculation**

**C.3.2 Concurrent Flow**

In a concurrent flow system, the process fluid begins its flow path at the bottom row of tubes, which is incident to the inlet air, and exists at the top row, which is swept by warm air. Thus, the coldest fluid exchanges heat with the warmest air, resulting in wall temperatures higher than those in a countercurrent arrangement. The design of the air-cooled heat exchanger can thus be kept simple, with no recirculation system required if the tube-wall temperature is kept above the specified minimum.

The main disadvantage of a concurrent flow system is that additional surface area is required as a result of the reduced mean temperature difference between the process fluid and the cooling air.

**C.3.3 Bare Tubes or Reduced Fin Density**

For viscous fluids and other fluids that exhibit low tube-side heat transfer coefficients, the tube-wall temperature can be increased by reducing the fin density or by using bare tubes. If the tube-wall temperature is thus maintained at or above the specified minimum value, no additional winterization protection is required.

### C.3.4 Varying the Active Heat Transfer Surface

Heat rejection from the process fluid can be controlled by removing bundles from service, usually by the use of valves, as the ambient temperature drops. This system minimizes heat losses and maintains a higher tube velocity in the active bundles. The higher tube velocity results in a higher tube-wall temperature.

The effectiveness of this system depends on whether the reduction in active surface area results in a tube-wall temperature above the specified minimum value. Pumping capacity should be checked to ensure that it is adequate for the additional pressure drop that results.

It can be necessary to purge or displace the contents of tubes in idle bundles. The stepwise nature of the operation can limit its applicability.

### C.3.5 Serpentine Coils

A serpentine coil design uses a single or limited number of continuous flow paths from the inlet to the outlet. Because of the limited number of flow paths, tubes with a large diameter [generally 50 mm to 150 mm (2 in. to 6 in.)] are used. The tubes can be finned or bare, depending on economics and the specified minimum tube-wall temperature that it is necessary to maintain.

This system usually requires high pressure drops, but the design is frequently favored for viscous fluids because there is little or no possibility of mal-distribution.

### C.3.6 Indirect Cooling

The normal design of an indirect (closed-loop tempered-water) cooling system uses recirculated water in a conventional shell-and-tube heat exchanger to cool the process fluid. The recirculated water is, in turn, cooled to a controlled temperature in an air-cooled heat exchanger that uses a fairly simple form of airflow control (variable speed drives, automatically controlled variable-pitch fans or louvers), but is not winterized. For ambient temperatures above 0 °C (32 °F), ordinary condensate or treated water may be used. For ambient temperatures less than or equal to 0 °C (32 °F), the water should be mixed with an amount of antifreeze, such as ethylene or propylene glycol, sufficient to lower the solution's freezing point to a value less than the lowest expected air temperature.

This system is usually applied to fluids with a high viscosity or a high pour point. The system offers several advantages for these fluids:

- a) better process temperature control;
- b) less chance of process fluid mal-distribution;
- c) better general operability;
- d) usually more economical operation.

However, an economic comparison should be made. C.10 provides an example of such a comparison.

### C.3.7 Duty Separation

The duty separation approach divides the process heat duty into two separate services. The intermediate temperature between the services is chosen to ensure that the tube-wall temperature in the upstream unit is above the specified minimum tube-wall temperature for the full range of ambient air temperatures. The upstream unit does not require winterization; only the downstream unit is winterized.

### C.3.8 Combinations

Depending on minimum air temperatures and specified minimum tube-wall temperatures, various combinations of the protection methods described in C.3.1 through C.3.7 can prove economically attractive. The following are examples of combination protective methods:

- a) combination of cocurrent and countercurrent bundles;
- b) cocurrent bare-tube bundles;
- c) duty separation, with varying fin densities, in subsequent bundles in series.

### C.3.9 Instrumentation

#### C.3.9.1 General

Figure C.1, Figure C.2, Figure C.3, Figure C.4, Figure C.5, and Figure C.6 illustrate typical instrumentation schemes for the systems described in C.3.1.1 through 3.1.4. The instrumentation methods shown are only suggestions.

#### C.3.9.2 System A

Typical instrumentation for system A (see Figure C.1 and Figure C.2) consists of a temperature sensor in the exit fluid stream and a controller that receives a signal from the sensor and sends signals to one or more devices that control the airflow. These devices may be outlet louvers with a louver actuator, automatically controlled variable-pitch fan hubs or variable-speed fan drivers.

The most commonly used arrangements include one or more of the following components:

- a) louvers with pneumatic operators, including valve positioners;
- b) automatically controlled variable-pitch fans responding to a pneumatic signal;
- c) pneumatic controllers having at least proportional-band and reset features; a manual/automatic setting is very desirable.

Electronic controllers and sensing elements may be used instead of pneumatic controllers. They usually require an electronic-to-pneumatic conversion at the fan hub or louver actuator.

#### C.3.9.3 Systems

##### C.3.9.3.1 Induced Draught

An induced-draught system typically employs several of the components discussed in C.3.9.2 [items b) and c)]. However, using the simple types of automatically controlled variable-pitch fans usually makes it necessary to use half the signal range from the controller for upflow and half for downflow. It is also necessary to cause a reversal of either the upflow or the downflow portion of the signal range. A simple way of reversing the signal is to use a reversing relay in conjunction with a low-limit relay, as shown in Figure C.3. Since it is necessary that the system operate in two modes (upflow and downflow), an ambient temperature sensor and a selector valve are commonly used for mode selection. The high-limit relay shown in Figure C.3 is required to cause the split-range operation to occur. The exit end of the last pass is normally the most vulnerable to winterization problems and should be located under the downflow fan in the warmest air.

##### C.3.9.3.2 Forced Draught

A forced-draught system, illustrated in Figure C.4, employs the same components as discussed in C.3.9.3.1.

### C.3.9.4 System C

Typical instrumentation for system C (see Figure C.5) consists of a temperature sensor in the exit process fluid stream, a controller that receives a signal from the sensor and sends signals to the exhaust louvers, and one or more variable speed drives or automatically controlled variable-pitch fans. Another temperature sensor (usually a long averaging bulb) is placed in the airstream above the bundle segment most vulnerable to freezing or other problems. A second controller receives a signal from this sensor and sends a signal to the partition louvers and the exhaust louvers. The exhaust louvers thus receive two control signals and respond to the one requiring the more closed position. A high- or low-pressure selector relay is typically used to determine which signal reaches the exhaust louvers. It is not good practice to delete either the partition louver or a separate actuator for the partition louver. Deletion of the partition louver leads to maximum cross-flow at all conditions and sacrifices heat transfer capability in certain ranges of operation while reducing cost very little.

The control elements between the controller and the variable speed drive or automatically controlled variable-pitch fan are the same as those discussed in C.3.9.3.1 and function in the same manner.

### C.3.9.5 System D

The typical instrumentation for system D (see Figure C.6) consists of a temperature sensor in the exit process fluid stream and a controller that receives a signal from the sensor and sends signals to the variable speed drives or automatically controlled variable-pitch fans and, optionally, to the exhaust louvers. A second temperature sensor (usually a long averaging bulb) is placed in the airstream below the bundle segment most vulnerable to freezing or other problems. For operation in cold climates with ambient temperatures below  $-29\text{ }^{\circ}\text{C}$  ( $-20\text{ }^{\circ}\text{F}$ ), a separate temperature sensor should be placed in the airstream above each fan, especially if only some of the fans are controlled by variable speed drives or variable-pitch fans. A second controller receives a signal from these sensors and sends a signal to the exhaust louvers, the bypass louvers (if separately actuated), and the inlet louvers. Where more than one sensor is used in a bay, the lowest temperature measured should be selected via control logic, to control the louver positions. Some of the inlet louvers may be manually operated, and the inlet louvers closest to the fans should be closed in the winter, effectively acting as a wind shield. Inlet louvers closer to grade are automatically controlled.

Where freezing of the fluid in the tubes can lead to tube failure and loss of containment, the automatic inlet and exhaust louvers' actuators should be specified to fail closed, and the automatic recirculation louvers specified to fail open, on loss of instrument air or control signal, to provide maximum winterization protection. Other configurations, such as fail in last position, may be considered only with approval of the Purchaser.

## C.4 Critical Process Temperatures

### C.4.1 Pour Points of Hydrocarbon Liquid Mixtures

Air-cooled heat exchangers that handle gas oil and residuum cuts can require winterization. The pour points of these hydrocarbon liquid mixtures vary from  $-51\text{ }^{\circ}\text{C}$  to  $63\text{ }^{\circ}\text{C}$  ( $-60\text{ }^{\circ}\text{F}$  to  $145\text{ }^{\circ}\text{F}$ ).

The pour point of a fraction of a hydrocarbon liquid cut with a known pour point cannot be predicted mathematically. The only realistic method of establishing the pour point of such a fraction is by measurement, using ASTM D97 [8].

The pour point of a blend of two hydrocarbon liquid cuts with known pour points can be approximated by calculation. Because of the imprecision of such calculations, however, when the actual pour point of the blend cannot be measured, a safety margin that respects the consequences of an air-cooled heat exchanger freezing up should be added to any predicted value.

NOTE Numbers in square brackets in this annex refer to references in the bibliography.

### C.4.2 Freezing Points of Hydrocarbons and Other Organic Liquid Pure Compounds

Table C.2 lists the freezing points of frequently encountered refinery hydrocarbon and organic liquid pure compounds. Air-cooled heat exchangers that process these liquids can require winterization.

### C.4.3 Water Solutions of Organic Compounds

Water solutions of some of the organic compounds in Table C.2 are also subject to freezing in air-cooled heat exchangers. Freezing-point-concentration relationships for these materials are valid only for very dilute solutions. Figure C.7, Figure C.8, and Figure C.9 show measured values for freezing points over the entire concentration range.

**Table C.2 — Freezing Points of Frequently Encountered Liquid Pure Components**

Compound	Relative Molecular Mass	Freezing Point	
		°C	(°F)
Water	18.0	0.0	(32.0)
Benzene	78.1	5.6	(42.0)
<i>o</i> -Xylene	106.2	−25.2	(−13.3)
<i>p</i> -Xylene	106.2	13.3	(55.9)
Cyclohexane	84.1	6.6	(43.8)
Styrene	104.1	−30.6	(−23.1)
Phenol	93.1	40.9	(105.6)
Monoethanolamine	61.1	10.3	(50.5)
Diethanolamine	105.1	25.1	(77.2)
Glycerol	92.1	18.3	(65.0)
Ethylene glycol	62.1	−13.0	(8.6)
Naphthalene	128.2	80.3	(176.5)

### C.4.4 Ammonium Bisulfide

Solid ammonium bisulfide ( $\text{NH}_4\text{HS}$ ) can be deposited by gas or vapor streams when the product of the partial pressures of ammonia ( $\text{NH}_3$ ) and hydrogen sulfide ( $\text{H}_2\text{S}$ ) exceeds the dissociation constant,  $K_d$ , at the temperature of interest and no liquid water is present.

Figure C.10 is a plot of  $K_d$  versus temperature. Deposition is not a problem in all-hydrocarbon streams, since the solubility of  $\text{NH}_4\text{HS}$  is negligible in hydrocarbons.

### C.4.5 High-pressure Gases

Certain gases at high pressure, including  $\text{C}_1$  to  $\text{C}_4$  paraffins and olefins, hydrogen sulfide and carbon dioxide, can form hydrates when saturated with water at temperatures above water's freezing point. These hydrates are solid crystals that can collect and plug air-cooled heat exchanger tubes. Figure C.11 shows the hydrate-formation conditions for these pure gases. Reference [12] gives semi-empirical methods for predicting hydrates in gas mixtures.

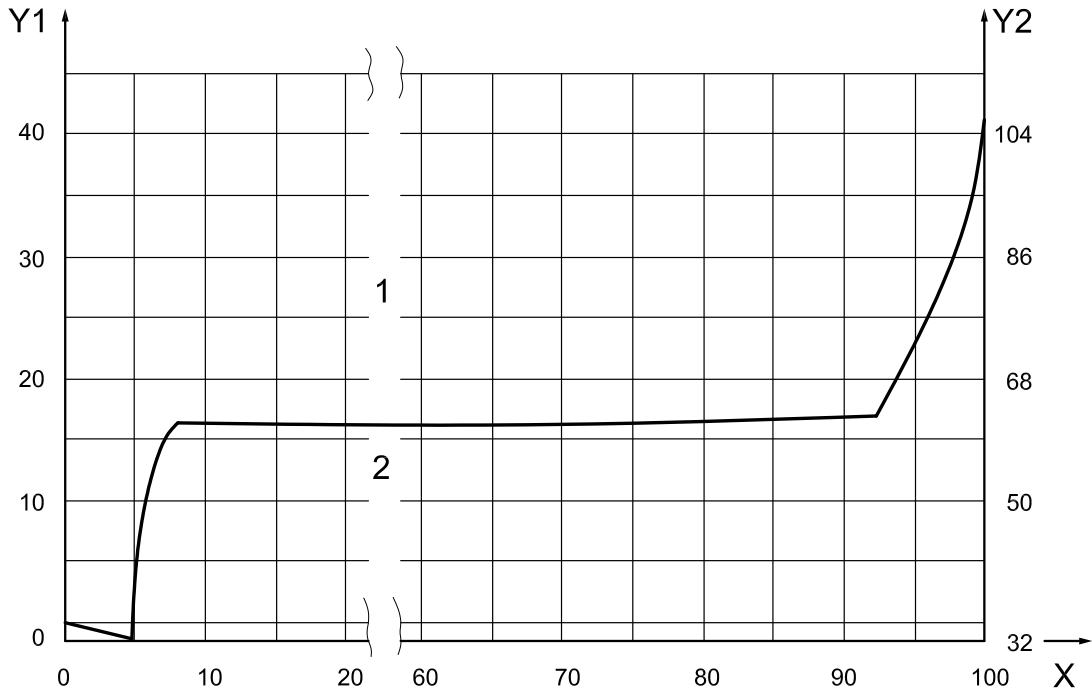

**Key**

X	phenol, percent mass fraction	1	phenol-water solution
Y1	temperature, degrees Celsius	2	solid
Y2	temperature, degrees Fahrenheit		

**Figure C.7 — Freezing Points of Phenol-water Solutions**

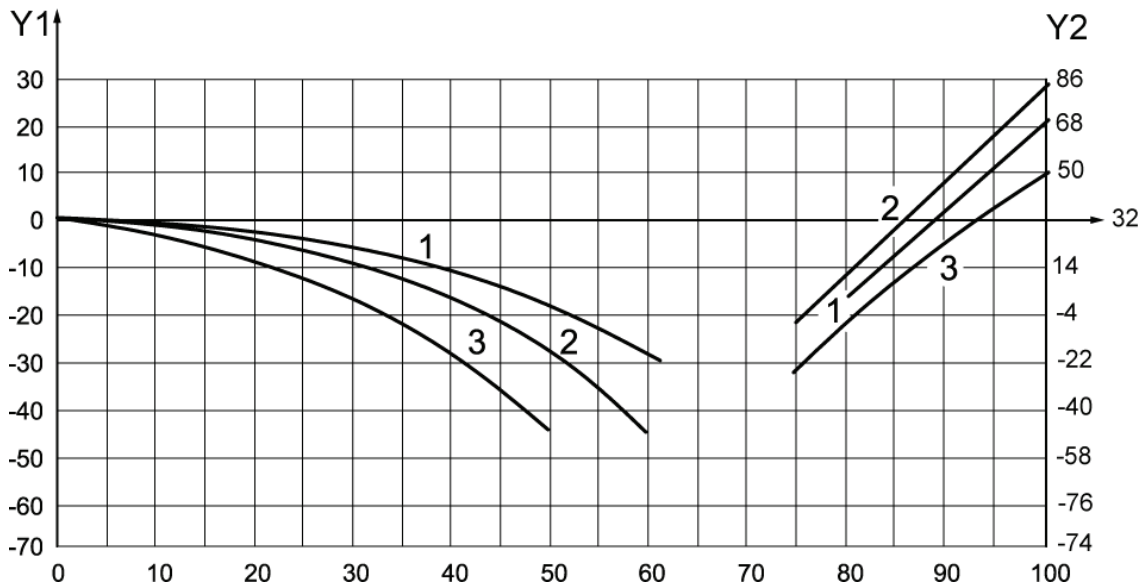

**Key**

Y1	temperature, degrees Celsius	1	triethanolamine
Y2	temperature, degrees Fahrenheit	2	diethanolamine
		3	monoethanolamine

**Figure C.8 — Freezing Points of Ethanolamine-water Solutions**

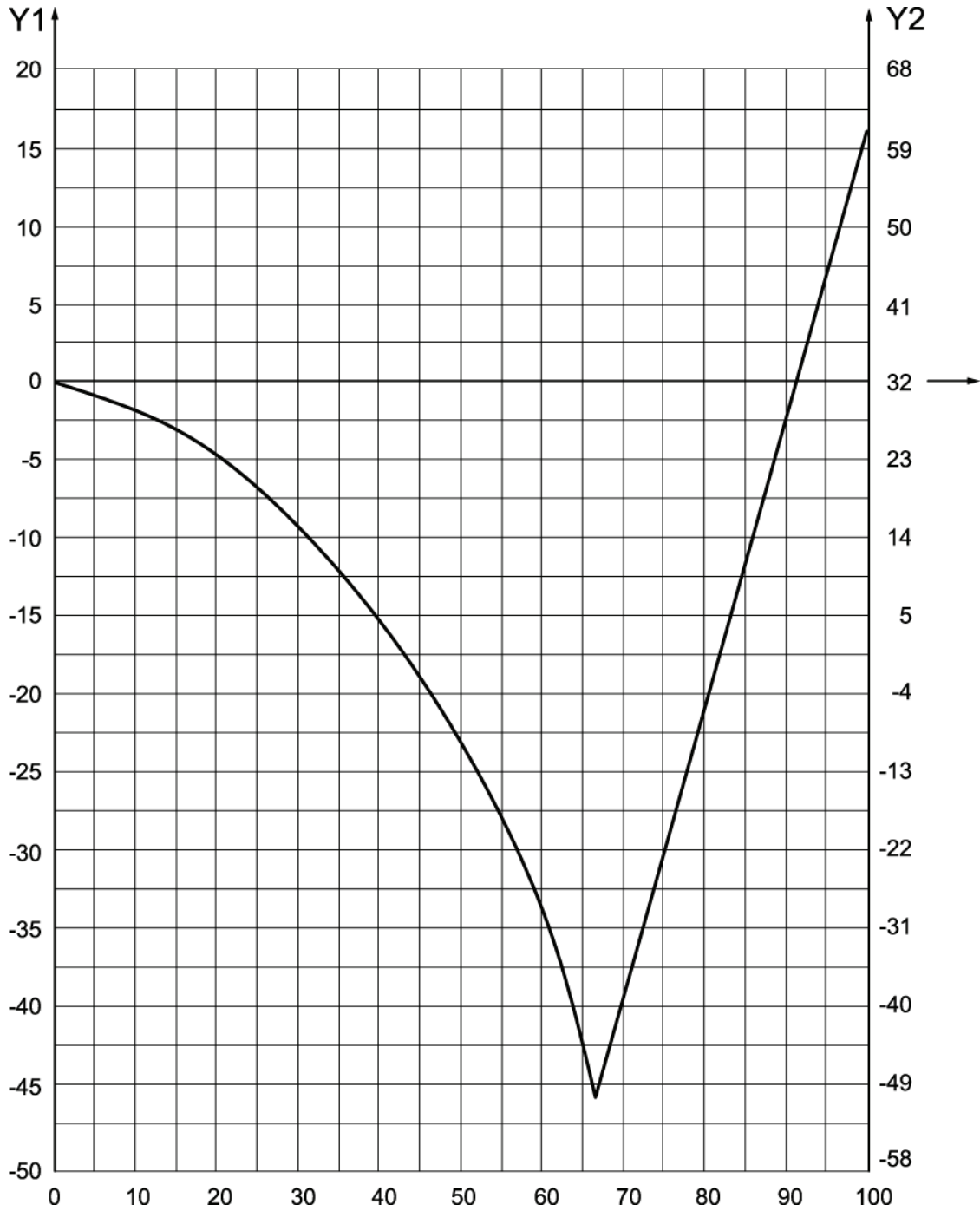

**Key**

- Y1 temperature, degrees Celsius
- Y2 temperature, degrees Fahrenheit

**Figure C.9 — Freezing Points of Glycerol-water Solutions**

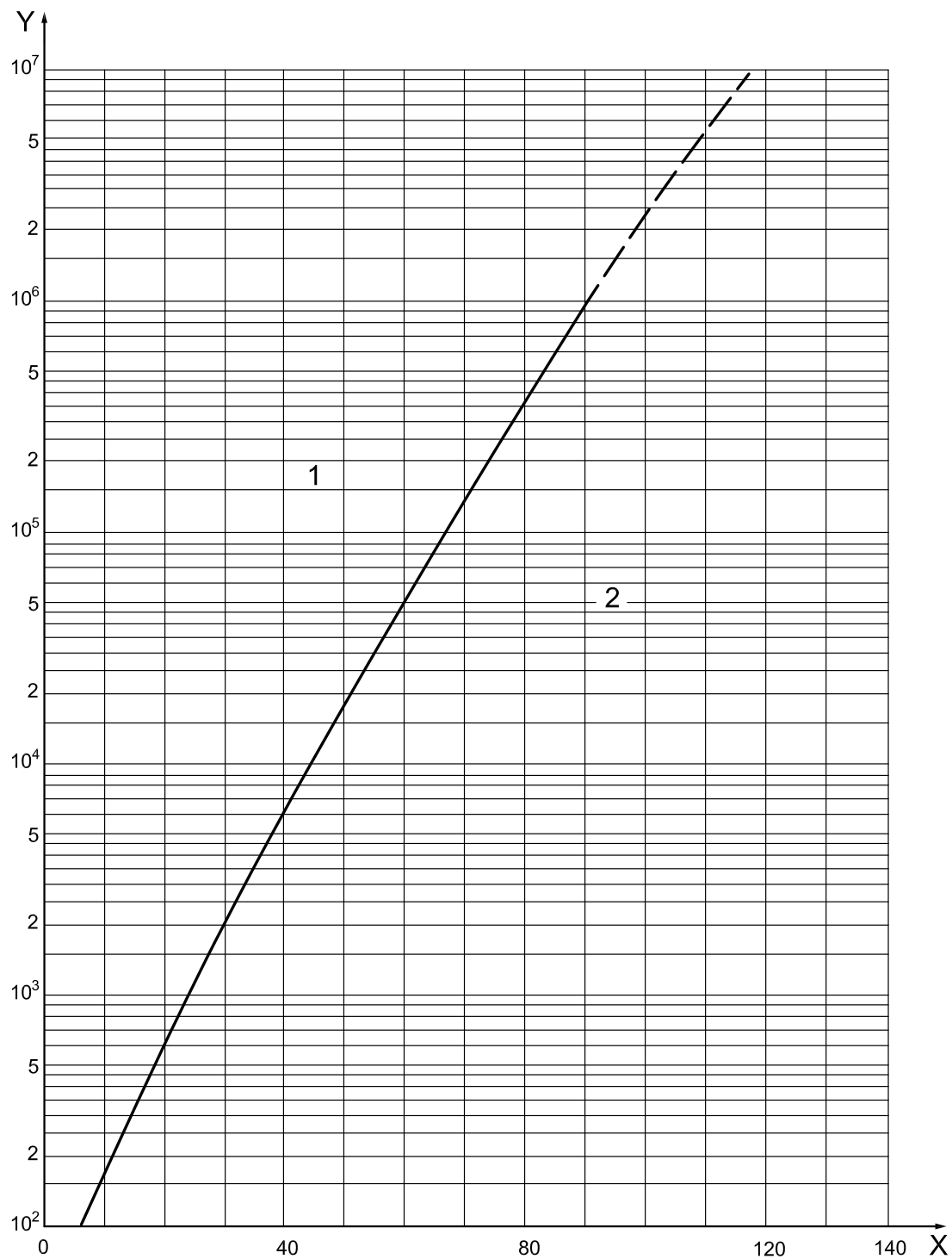
**Key**

X temperature, degrees Celsius

Y  $K_d$ , ( $\text{kPa}$ )<sup>2</sup>1 region of deposition of solid  $\text{NH}_4\text{HS}$ 

2 region of no deposition

NOTE To express  $K_d$  in ( $\text{psia}$ )<sup>2</sup>, divide by 47,537.**Figure C.10 — Dissociation Constant of Ammonium Bisulfide ( $\text{NH}_4\text{HS}$ )**

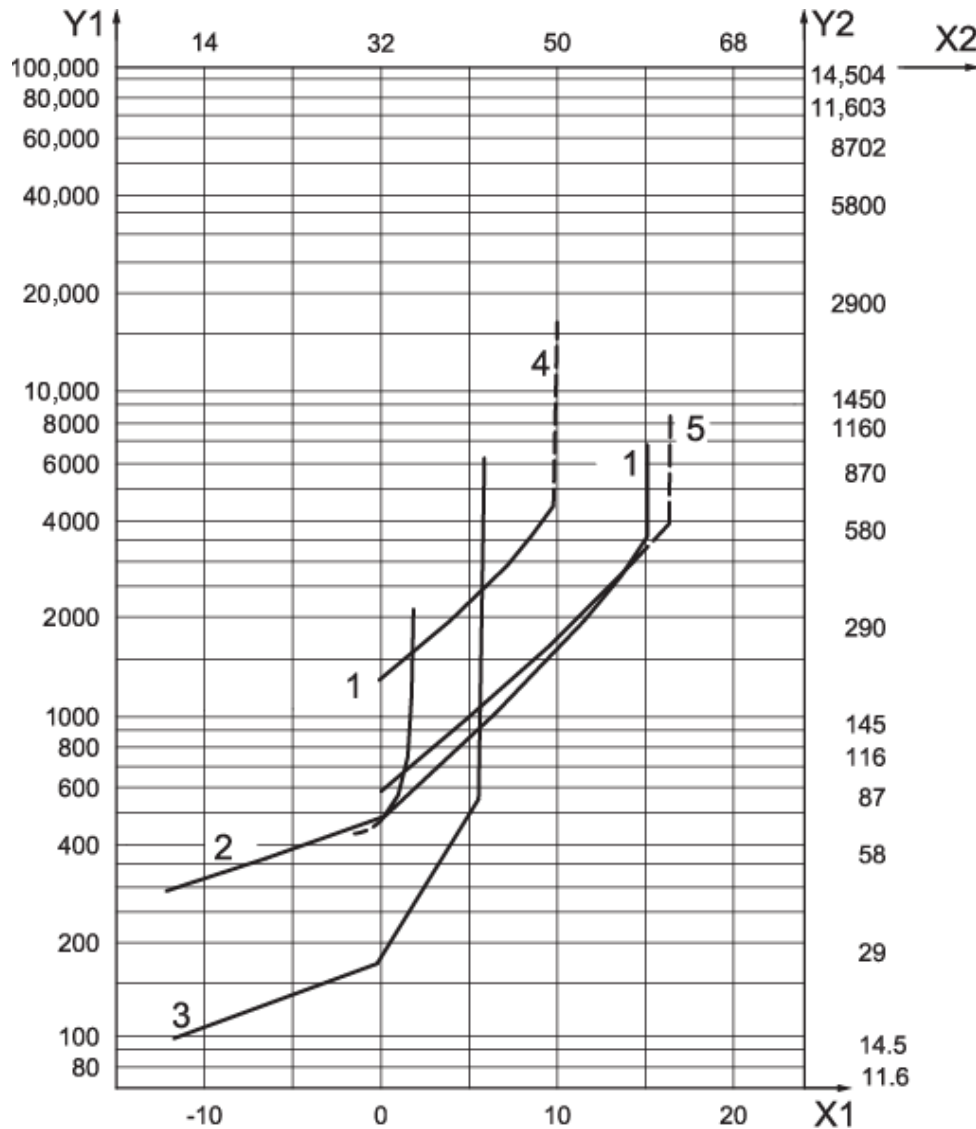

NOTE 1 The curves in the figure indicate the pressure-temperature regions in which gas hydrate formation is favored (above and to the left of the appropriate curve).

NOTE 2 Equilibrium conditions are shown in the figure; however, since hydrate systems typically exhibit metastable tendencies, a metastable hydrate phase can exist far out of the hydrate region. In addition, hydrate formation does not always occur in the region in which formation is favored.

NOTE 3 The figure shows the equilibrium hydrate conditions to within 2 % of the pressure.

NOTE 4 The discontinuities in the lines correspond to changes in phase of the non-hydrate phases. For multi-component systems, hydrate formation conditions can be determined using the procedures outlined in Reference [12]. It is noted that small amounts of impurities can exert a very strong influence on hydrate formation conditions.

NOTE 5 Sources of hydrate equilibrium data for these figures are listed in Reference [12].

NOTE 6 The figure and these notes are taken from Chapter 9 of Reference [12].

**Key**

X1	temperature, degrees Celsius	1	propene (propylene)
X2	temperature, degrees Fahrenheit	2	ethane
Y1	pressure, kPa	3	propane
Y2	pressure, psia	4	carbon dioxide
		5	ethylene

**Figure C.11 — Hydrate Pressure-temperature Equilibria**

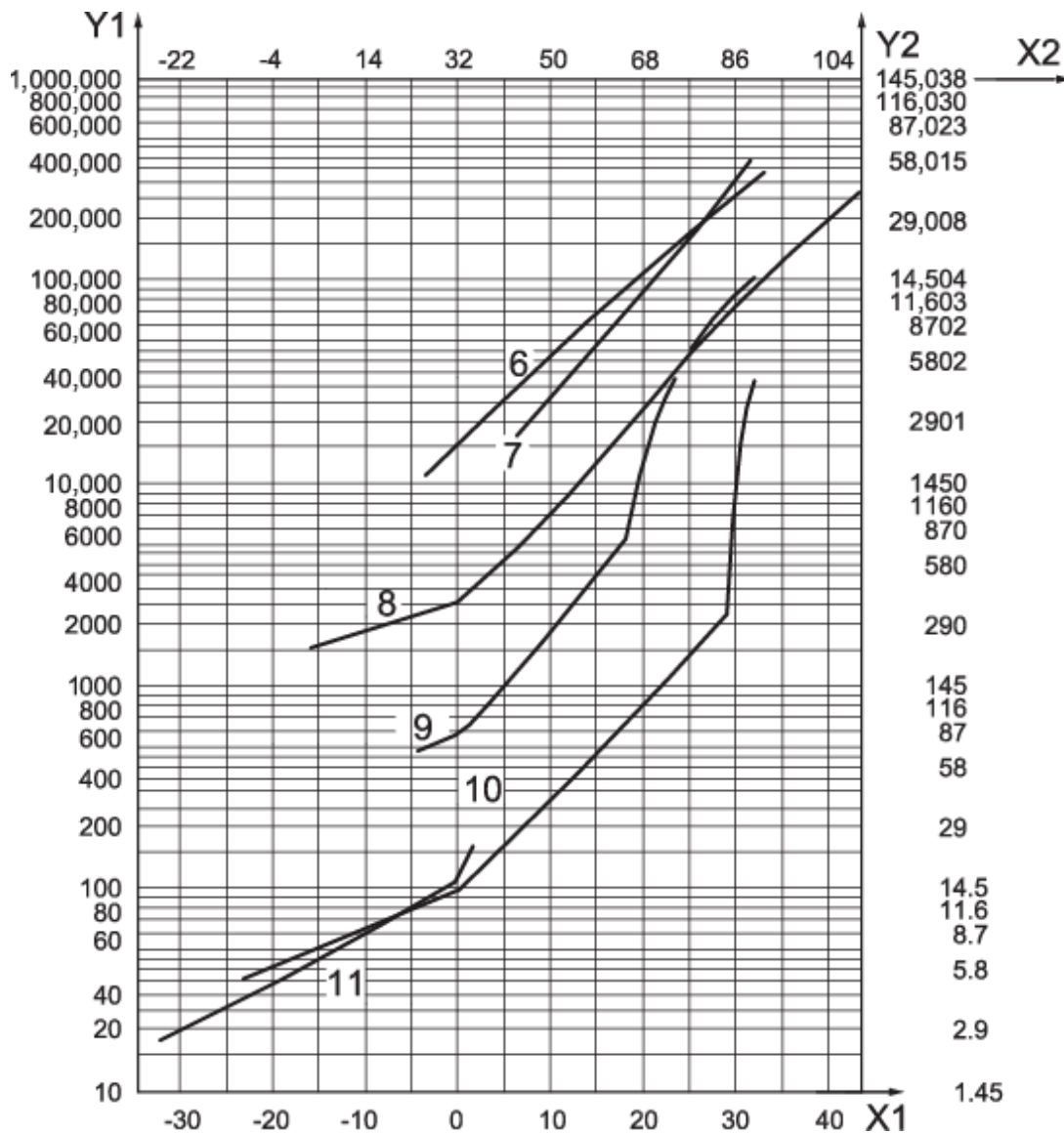

NOTE 1 The curves in the figure indicate the pressure-temperature regions in which gas hydrate formation is favored (above and to the left of the appropriate curve).

NOTE 2 Equilibrium conditions are shown in the figure; however, since hydrate systems typically exhibit metastable tendencies, a metastable hydrate phase can exist far out of the hydrate region. In addition, hydrate formation does not always occur in the region in which formation is favored.

NOTE 3 The figure shows the equilibrium hydrate conditions to within 2 % of the pressure.

NOTE 4 The discontinuities in the lines correspond to changes in phase of the non-hydrate phases. For multicomponent systems, hydrate formation conditions can be determined using the procedures outlined in Reference [12]. It is noted that small amounts of impurities can exert a very strong influence on hydrate formation conditions.

NOTE 5 Sources of hydrate equilibrium data for these figures are listed in Reference [12].

NOTE 6 The figure and these notes are taken from Chapter 9 of Reference [12].

#### Key

X1	temperature, degrees Celsius	6	nitrogen	10	hydrogen sulfide
X2	temperature, degrees Fahrenheit	7	argon	11	2-methylpropane
Y1	pressure, kPa	8	methane		
Y2	pressure, psia	9	ethene (ethylene)		

**Figure C.11 — Hydrate Pressure-temperature Equilibria (continued)**

## C.5 Tube-wall Temperature Calculations

### C.5.1 General

**C.5.1.1** The need for winterization of air-cooled heat exchangers is a function of the tube-wall temperature resulting from the inlet air temperature and the critical process temperature of the fluid. Consideration should be given to the type of design, the operating modes and the fluid flow regimen to predict tube-wall temperatures accurately.

**C.5.1.2** In cross-flow countercurrent air-cooled heat exchanger bundles, the worst condition usually exists at the outlet of the bottom row of tubes, with the tubes in the clean condition. At this location, the air that comes in contact with the tubes is at its lowest temperature, and the tube-side fluid is also at the lowest possible temperature. This is usually the critical location, but it can be necessary to consider other locations also. Axial-flow fans do not provide completely even airflow distribution. The designer should add at least 20 % to the air-side heat transfer rate to account for areas of high airflow (see factor  $f_a$  in C.5.2). The designer should also ensure good tube-side flow distribution within the tube bundle.

To calculate the tube-wall temperature, it is necessary to determine the air-side and tube-side resistances at each location under consideration. Such information can be obtained from the original manufacturer or another suitable source.

### C.5.2 Symbols

$A$	total outside surface area of the bottom layer of tubes, in $m^2$ ( $ft^2$ )
$A_b$	outside surface area of the bare tube per unit length, in $m^2/m$ ( $ft^2/ft$ )
$A_f$	surface area of the fin per unit length of the tube, in $m^2/m$ ( $ft^2/ft$ )
$A_i$	inside surface area of the tube per unit length, in $m^2/m$ ( $ft^2/ft$ )
$A_o$	outside surface area of the finned tube per unit length, in $m^2/m$ ( $ft^2/ft$ )
$f_a$	air-side heat transfer coefficient multiplier to account for airflow mal-distribution (the recommended minimum value is 1.2)
$r$	local overall thermal resistance, in $m^2 \cdot K/W$ ( $^{\circ}F \cdot ft^2 \cdot h/Btu$ )
$r_c$	local clean overall thermal resistance, in $m^2 \cdot K/W$ ( $^{\circ}F \cdot ft^2 \cdot h/Btu$ )
$r_{ds}$	air-side fouling resistance, in $m^2 \cdot K/W$ ( $^{\circ}F \cdot ft^2 \cdot h/Btu$ )
$r_{dt}$	tube-side fouling resistance, in $m^2 \cdot K/W$ ( $^{\circ}F \cdot ft^2 \cdot h/Btu$ )
$r_{fs}$	local air-side resistance, in $m^2 \cdot K/W$ ( $^{\circ}F \cdot ft^2 \cdot h/Btu$ )
$r_{ft}$	local tube-side resistance, in $m^2 \cdot K/W$ ( $^{\circ}F \cdot ft^2 \cdot h/Btu$ )

- $r_m$  total metal resistance of the tube, in  $m^2 \cdot K/W$  ( $^{\circ}F \cdot ft^2 \cdot h/Btu$ )
- $r_{mf}$  fin metal resistance, in  $m^2 \cdot K/W$  ( $^{\circ}F \cdot ft^2 \cdot h/Btu$ )
- $r_{mt}$  tube metal resistance based on the inside surface area of the tube, in  $m^2 K/W$  ( $^{\circ}F ft^2 h/Btu$ )
- NOTE An exact calculation of  $r_{mt}$  requires that the tube metal resistance be based on the logarithmic mean surface area of the tube; however, the relatively insignificant magnitude of the error caused by basing the tube metal resistance on the inside surface area of the tube does not justify the complexity introduced by the use of the logarithmic mean surface area.
- $T_B$  bulk temperature of the tube-side fluid at the location where the wall temperature is to be calculated, in  $^{\circ}C$  ( $^{\circ}F$ )
- $t_B$  bulk temperature of the air at the location where the wall temperature is to be calculated, in  $^{\circ}C$  ( $^{\circ}F$ )
- $T_w$  tube-wall temperature, in  $^{\circ}C$  ( $^{\circ}F$ )
- $U$  local overall heat transfer coefficient referred to the outside surface, in  $W/m^2 K$  ( $Btu/h ft^2 ^{\circ}F$ )
- $\phi$  fin efficiency
- $\phi_o$  efficiency of the finned tube surface

### C.5.3 Calculations

**C.5.3.1** Once the various resistances have been determined, the wall temperature can be predicted by prorating the resistances relative to the temperature at the outlet or other critical areas. This can be done using Equations (C.1) to (C.8):

$$U = 1/r \quad (C.1)$$

$$r = (r_{ft} + r_{dt}) (A_o / A_i) + r_{mt} (A_o / A_i) + (1 / \phi_o) (r_{fs} + f_a) + r_{ds} \quad (C.2)$$

**C.5.3.2** Fins do not cover all of the tube surface, and since the exposed bare tube surface may be considered to have an efficiency of 1.00, the efficiency of the finned tube surface is always higher than that of the fins alone. Thus,

$$f_a = 1 - (A_f / A_b) (1 - \phi) \quad (C.3)$$

**C.5.3.2.1** Fin efficiency is a complex calculation. It can, however, be replaced with an equivalent fin metal resistance, designated as  $r_{mf}$ . This metal resistance reaches a constant maximum value for an outside resistance above some value determined by fin height, thickness, and thermal conductivity. For standard aluminum fins, 90 % of this value is reached at air-side resistances ( $r_{fs}$ ) that are lower than those normally encountered. The fin metal resistance for these calculations may be considered constant with negligible error.

The overall resistance equation can, therefore, be rewritten in the following form:

$$r = (r_{ft} + r_{dt}) (A_o / A_i) + r_m + (r_{fs} / f_a) + r_{ds} \quad (\text{C.4})$$

where

$$r_m = r_{mf} + r_{mt} (A_o / A_i)$$

$$r_{mf} = [(1 - f_o) / f_o] (r_{fs} / f_a) + r_{ds}$$

**C.5.3.2.2** Tables C.6 and C.7 provide values of  $r_m$  for tubes of several common materials with an outside diameter of 25.4 mm (1 in.) and aluminum fins 0.4 mm (0.016 in.) thick and 15.9 mm ( $5/8$  in.) high. Other sizes and fin materials require a fin metal (fm) efficiency calculation to define  $r_{mf}$  for the combination. For fin efficiency curves, refer to textbooks such as References [13], [14], and [15].

**C.5.3.3** Initially, it is best to assume that the unit is clean. Tube-side fouling increases the surface temperature, since the fluid contact is then on the surface of the fouling material. The basic resistance equation can be rewritten as:

$$r_c = r_{ft} (A_o / A_i) + r_m + (r_{fs} / f_a) \quad (\text{C.5})$$

The equations are the same for bare-tube exchangers, except that  $\phi_o = 1$  and  $A_o$  is the outside surface area of the bare tube,  $A_b$ . Since the performance of bare-tube exchangers is sensitive to pitch arrangement, the designer should refer to bare-tube correlations, such as those described in Reference [16] for air-side heat transfer coefficient calculations.

The overall resistance for bare tubes is, therefore, calculated as follows:

$$r = (r_{ft} + r_{dt}) (A_b / A_i) + r_{mt} + (A_b / A_i) + (r_{fs} / f_a) + r_{ds} \quad (\text{C.6})$$

For a clean bare-tube unit, this equation reduces to

$$r_c = r_{ft} (A_b / A_i) + r_{mt} (A_b / A_i) + (r_{fs} / f_a) \quad (\text{C.7})$$

**C.5.3.4** The tube-wall temperature can be calculated on the basis of a prorated portion of the clean overall resistance:

$$T_w = T_B - (r_{ft} / r_c) (A_o / A_i) (T_B - t_B) \quad (\text{C.8})$$

Sample calculations are given in C.11.

**C.5.3.5** Single-pass, multiple-row air-cooled heat exchangers are more susceptible to freezing and pour-point problems because of variations in the layer-to-layer mean temperature difference, with the bottom row exchanging more heat than any of the upper rows. This means that the mixed outlet fluid temperature cannot be used safely; instead, the bulk tube-side fluid outlet temperature should be calculated for each row of concern.

Two-phase fluids in a single pass with multiple rows require a more complete analysis that recognizes the separation of phases in the header. The problem becomes more complex when the units are not designed with equal flow areas in each pass. With viscous fluids, the problem of extreme flow mal-distribution arises. This is difficult to calculate and these fluids should be handled in as few parallel passes as possible. A single, continuous serpentine coil is the ideal approach.

**C.5.3.6** When the tube-wall temperature is calculated, the following operating questions should be considered.

- a) At lower temperatures, how much less airflow is needed to remove the required heat?
- b) Does the unit operate with fans off or on?
- c) Does the unit have louvers?
- d) Has an automatically controlled variable-pitch fan or another means been provided to reduce airflow?
- e) Is the unit operating at partial load so that the tube-side flow conditions affect the wall temperature?

## **C.6 Heat Losses**

### **C.6.1 General**

**C.6.1.1** Air-cooled heat exchangers are usually large pieces of equipment that are not well suited to being enclosed. Where it is necessary that airflow be contained or controlled, louvers or sheet metal panels are normally used. Provisions should be made for shutting down, starting up, and holding such equipment at standby conditions during periods of minimum air temperature. Under these conditions, the process fluid can be cooled below its critical process temperature unless airflow through the bundle is nearly stopped and an auxiliary source of heat is provided.

**C.6.1.2** Unless the amount of heat that is lost by louver leakage and by conduction through enclosing panels can be determined, there is no certainty that enough heat can be added by auxiliary means. Thus, it is necessary that the problem of evaluating the auxiliary heat source begin with determining how much heat can be lost under a particular set of circumstances. Examples of heat loss calculations are given in C.12.

**C.6.1.3** The most important case to consider is that of no process flow with fans off, minimum air temperature and fairly high wind velocity. One should assume that it is necessary to maintain the bundle at least 11 °C to 17 °C (20 °F to 30 °F) above the critical process temperature.

**C.6.1.4** A less important case is that of short-duration heat loss when there is no process flow with fans on, minimum air temperature and fairly high wind velocity. These conditions should occur only during the transition period from operation to shutdown or vice versa, so an example of this case is not given in C.12. The equations of the "fans-off" example can be used to find the louver leakage by using the pressure drop that exists with fans on instead of the pressure drop resulting from the effect of the hot-air column.

**C.6.1.5** Several factors should be considered when the auxiliary heat source mentioned in C.6.1.1 and C.6.1.2 is installed. A choice should be made about what fluid to use (usually steam but occasionally an antifreeze solution). The location of the heat source should also be decided. A separate coil that is one row deep is usually placed immediately below the process bundle; however, special considerations can dictate a less effective placement, such as inside the recirculation duct. Steam coils located directly below the process bundle have proven to be unreliable and impractical in cold climates where the ambient temperature is less than -29 °C (-20 °F). The preferred heat medium in such cases is an anti-freeze solution. The use of steam space heaters located below the fans in the enclosed plenum of system D air coolers has also been successful. These space heaters are self-contained units, complete with their own motor and fan, and are less prone to freezing since they are not located in the high-velocity airstream directly above the main fans.

## C.6.2 Louver Leakage

Louvers of standard manufacture, maintained in good condition, have a leakage area of not more than 2 % of the face area when closed. This can be reduced to not more than 1 % if special, more costly designs are used. The air leakage rate may be calculated for either case. (See C.12.1.3 or C.12.2.3 for a sample calculation.) Tests on standard louvers indicate that an average louver has only about half the leak area predicted by maximum tolerances.

## C.6.3 Surface Heat Loss

The heat loss from the sheet metal panels that form the enclosure is a function of the air velocity both inside and outside, as well as the temperature differential between the enclosed air and the ambient air. (The overall heat transfer coefficient for this surface is calculated for a range of wind velocities in C.12.1.4 and C.12.2.4.) Calculations of this type can also be used to determine the heat loss from the hot air being recirculated through the recirculation duct during normal operation. The heat loss calculation for the duct can be used to assure that the required air temperature to the bundle is maintained when the recirculated air is blended with the cold inlet air.

## C.7 Guidelines

### C.7.1 General

Air-cooled heat exchangers are normally designed to dissipate a given heat duty in summer conditions and also dissipate the same heat duty (or more) in winter conditions. Additional measures are taken to ensure proper operation during periods of minimum air temperature. These measures include recirculating a fraction of the air so that it mixes with and heats the incoming cold air. Ducts and louvers are required to direct this recirculation.

Provisions to achieve thorough mixing of the recirculated air with the cold inlet air would be prohibitively expensive. The set point for the average temperature of this mixed airstream should, therefore, be above the critical process temperature. For instance, the set point for vacuum steam condensers is usually 1.5 °C to 4.5 °C (35 °F to 40 °F). It is important to measure the average air temperature in these systems with an averaging bulb 4 m to 6 m (12 ft to 20 ft) long that spans the airstream, and not with a sensor that measures temperature at only one point.

### C.7.2 Design Methods

#### C.7.2.1 System C — Contained Internal Circulation

System C (see Figure C.5) operates in two modes, the summer mode and the winter mode. In the summer mode, both fans move air upward and no air is recirculated. In the winter mode, one fan (normally on the exit end of the unit) moves air downward. This also causes a part of the air that is moved upward through the bundle (on the end opposite the exit) to flow horizontally across the top of the bundle through a bypass louver and then downward through the bundle. Only enough air makes this journey to cause the average temperature of the mixed air entering the bundle on a downward traverse to satisfy a preset value. The duct above the bundle should be adequately sized for the maximum quantity of air that is required. A conservative design rule is to size the duct cross-section based on a linear air velocity of 305 m/min (1000 ft/min), using the quantity of air that passes through the bypass louvers. In no case should the duct cross-section exceed that required to recirculate 100 % of the heated air.

An alternative method that has proved to be adequate is to make the height of the duct space above the top of the side frame one-tenth of the tube length, rounding to the nearest 0.15 m (0.5 ft). This requires a 1.2 m (4 ft) height for tube bundles 12 m (40 ft) in length, and a 1.1 m (3.5 ft) height for tube bundles 11 m (36 ft) in length.

### C.7.2.2 System D — External Recirculation

System D (see Figure C.6) operates in only one mode. This means that the air movement is always upward through the bundle. When inlet air temperatures are low enough, however, part of this air leaves the bundle and returns to the fan inlet by passing over the side or the end of the bundle through a duct with a bypass louver. The unrestricted flow area in the exhaust air plenum, measured from the top of the tube bundle side frame to the underside of the outlet louver support beam should not be less than the recirculation duct width.

This external recirculation duct may be conservatively sized using the same rules as for the internal recirculation duct described in C.7.2.1. The application of these rules usually results in a duct with a cross-sectional area equal to 20 % to 30 % of the bundle face area. In cold climates where the ambient temperature is less than  $-29\text{ }^{\circ}\text{C}$  ( $-20\text{ }^{\circ}\text{F}$ ), or if it is necessary that more than 75 % of the heated air be recirculated, the duct cross-sectional area should be a minimum of 30 % of the bundle face area and can approach 40 % of the bundle face area. In calculating the total amount of air to recirculate, a  $5\text{ }^{\circ}\text{C}$  ( $9\text{ }^{\circ}\text{F}$ ) margin should be added to the required minimum plenum temperature.

## C.8 Mechanical Equipment

### C.8.1 General

When mechanical equipment is being operated in extremely cold or hot environments, care should be taken that the equipment is specified and designed for the temperature extremes to which it is exposed. It is possible that two heat exchangers located side by side can have different design temperature considerations if one has only airflow control and the other has an external recirculation system.

### C.8.2 Design Temperatures

**C.8.2.1** Unless otherwise agreed upon, the minimum design temperature for the mechanical equipment should be the minimum design air temperature.

**C.8.2.2** Unless otherwise agreed upon, the maximum design temperature for mechanical equipment in the airstream exiting the heat exchanger should be equal to the maximum process or auxiliary heating fluid temperature. The maximum air temperature can occur when the fans are not operating and the louvers are closed.

**C.8.2.3** The maximum design temperature for the mechanical equipment in the inlet or recirculation airstream depends on the type of winterization system, as described in C.8.2.3.1 through C.8.2.3.3. Each operating mode (start-up, normal operation, and shutdown) should be examined to determine the design temperature to use.

**C.8.2.3.1** In an airflow control system (see Figure C.1 and Figure C.2), the maximum design temperature for equipment in the inlet airstream is the design dry-bulb air temperature.

**C.8.2.3.2** In a system with noncontained or contained internal recirculation (see Figure C.3, Figure C.4 and Figure C.5), the maximum design temperature for the equipment in the inlet airstream should be the temperature of the air exiting the reversed-airflow fan during recirculation, plus a safety factor of  $14\text{ }^{\circ}\text{C}$  ( $25\text{ }^{\circ}\text{F}$ ).

**C.8.2.3.3** Since the air is not completely mixed in an external recirculation system (see Figure C.6), the design temperature for the mechanical equipment in the inlet airstream should be selected carefully. The danger lies in exposing the mechanical equipment to hot stratified air that has not been mixed with the cooler inlet air. This problem is most prevalent during start-up and during turndown operation.

### **C.8.3 Design Temperature Range**

Most mechanical equipment operates satisfactorily between air temperatures of  $-29\text{ }^{\circ}\text{C}$  ( $-20\text{ }^{\circ}\text{F}$ ) and  $40\text{ }^{\circ}\text{C}$  ( $104\text{ }^{\circ}\text{F}$ ) without any modifications. However, since material selection and design techniques are not standardized for most components of mechanical equipment, the standardized operating ranges vary among manufacturers.

### **C.8.4 Typical Characteristics and Operating Ranges for Standard Mechanical Equipment**

#### **C.8.4.1 General**

The characteristics and air temperature ranges given in C.8.4 are typical and are not intended to limit the application of any equipment. The suitability of continuously operating a particular piece of equipment at a specified design temperature should be confirmed with the Vendor.

#### **C.8.4.2 Fans with Manually Adjustable Pitch in Continuous Operation [ $-54\text{ }^{\circ}\text{C}$ to $121\text{ }^{\circ}\text{C}$ ( $-65\text{ }^{\circ}\text{F}$ to $250\text{ }^{\circ}\text{F}$ )]**

For best results in cold weather, fans with manually adjustable pitch should have hubs made of ductile iron, aluminum or another material with good ductility. The blade material should exhibit similar characteristics.

#### **C.8.4.3 Fans with Automatically Controlled Variable Pitch in Continuous Operation [ $-32\text{ }^{\circ}\text{C}$ to $121\text{ }^{\circ}\text{C}$ ( $-25\text{ }^{\circ}\text{F}$ to $250\text{ }^{\circ}\text{F}$ )]**

The criteria in C.8.4.2 for hubs and blades for fans with manually adjustable pitch also apply to automatically controlled variable-pitch fans. Since the automatic pitch device for each manufacturer's fans is different, the actual operating temperature range and recommendations for extending the range should be obtained from the manufacturer.

#### **C.8.4.4 Electric Motors [ $-30\text{ }^{\circ}\text{C}$ to $40\text{ }^{\circ}\text{C}$ ( $-22\text{ }^{\circ}\text{F}$ to $104\text{ }^{\circ}\text{F}$ )]**

The upper limit on operating temperature for electric motors may be raised by substituting an insulation system and a bearing lubricant with a higher temperature rating. In most cold weather applications, space heaters are provided in the motors to maintain the internal air temperature above the dew point.

#### **C.8.4.5 V-belts [ $-40\text{ }^{\circ}\text{C}$ to $60\text{ }^{\circ}\text{C}$ ( $-40\text{ }^{\circ}\text{F}$ to $140\text{ }^{\circ}\text{F}$ )] and High-torque-type Positive-drive Belts [ $-34\text{ }^{\circ}\text{C}$ to $85\text{ }^{\circ}\text{C}$ ( $-30\text{ }^{\circ}\text{F}$ to $185\text{ }^{\circ}\text{F}$ )]**

Belt life is reduced when belts are operated outside the temperature ranges given in this subsection. Special belts are available for operation above and below these ranges. The life expectancy of special belts can be shorter than that of standard belts.

#### **C.8.4.6 Gear Drives [ $-18\text{ }^{\circ}\text{C}$ to $77\text{ }^{\circ}\text{C}$ ( $0\text{ }^{\circ}\text{F}$ to $170\text{ }^{\circ}\text{F}$ )]**

Operation of gear drives below the range given in this subsection requires changing to a lubricant suitable for the temperature and possibly adding an oil heater. Actual temperature ranges and recommendations to extend the temperature range should be obtained from the gear drive manufacturer.

#### **C.8.4.7 Bearings [ $-45\text{ }^{\circ}\text{C}$ to $121\text{ }^{\circ}\text{C}$ ( $-50\text{ }^{\circ}\text{F}$ to $250\text{ }^{\circ}\text{F}$ )]**

For bearings, the temperature range in this subsection can be extended by substituting a lubricant suitable for the required temperature range.

#### **C.8.4.8 Steel or Aluminum Louvers [−40 °C to 121 °C (−40 °F to 250 °F)]**

Louvers should be designed for the expected loads during operation at low temperatures. This can require selecting a more ductile material. Snow and ice loads, as well as the effect of ice on the design and operation of the linkage, should be considered in the design. The temperature range can be extended by selecting different bearing materials.

#### **C.8.4.9 Pneumatic Diaphragm Actuators [−40 °C to 82 °C (−40 °F to 180 °F)], Pneumatic Piston Actuators [−34 °C to 79 °C (−30 °F to 175 °F)] and Pneumatic Positioners [−40 °C to 71 °C (−40 °F to 160 °F)]**

The temperature range given in this subsection for pneumatic actuators and positioners can be extended by changing materials of several of the components, including but not limited to diaphragms and O-rings.

### **C.8.5 Auxiliary Heating Equipment**

**C.8.5.1** When steam coils are used with any of the winterization systems, the maximum design temperature for the exposed mechanical equipment can be determined by the steam saturation temperature. The radiation effect of the steam coil is negligible and may be omitted when the design temperatures of mechanical equipment located below a steam coil are defined. Steam coils are normally used during start-up and shutdown, but not during general operation. A steam trap that fails in the open position should be used to avoid freezing of the steam coil.

**C.8.5.2** Other types of auxiliary heating equipment, such as glycol/water coils, heat-transfer fluid coils, electric heaters and space heaters, are being used successfully.

## **C.9 Start-up and Shutdown Procedures**

### **C.9.1 General**

The procedures in C.9 are intended to supplement users' established procedures, not to replace them. The procedures apply only to air-cooled heat exchangers with some degree of winterization, from the simplest (airflow control only) to the most complex (full external air recirculation). The procedures apply only to start-up and shutdown during cold weather.

### **C.9.2 Start-up Procedures**

**C.9.2.1** Before start-up, all snow or ice or protective coverings that can affect louver or fan operation should be removed. Depending on the particular weather conditions, snow and ice can sometimes be removed by activating the start-up heating coil. Care should be taken not to damage the top louvers. Workers should not walk on the louvers.

**C.9.2.2** The instrument air supply should be checked to ensure that it is functioning and free from water.

**C.9.2.3** Instruments and control valves should be checked for satisfactory operation.

**C.9.2.4** The operation of all louvers, linkages, and automatically controlled variable-pitch fans (if used) should be checked.

**C.9.2.5** The louvers should be closed, and the start-up heating coil (if not already activated) should be activated. If the heating system is a steam coil, the steam trap should be checked to ensure that it is functioning satisfactorily. The tube bundle and the air surrounding it should be at a temperature higher than the critical process temperature before the bundle is placed in service.

**C.9.2.6** For systems with internal recirculation (see Figure C.3, Figure C.4, and Figure C.5), the control system should be verified as being in the winter mode, that is, with the fan nearest the process outlet pitched to blow air down through the bundle and the other fan pitched to force air up through the bundle. Both fans should be set at their maximum airflow position.

**C.9.2.7** For systems with external recirculation (see Figure C.6), the following steps should be taken.

- a) When a linkage between the top louvers and the bypass louvers is provided, it should be checked to ensure that the bypass louvers are working as intended.
- b) The operation and means of actuation of the inlet louvers should be checked.
- c) The exchanger's enclosure should be checked to ensure that no large openings are allowing ambient air into the enclosure.

**C.9.2.8** Normal procedures should be followed when the unit is started up; however, certain process conditions can necessitate special start-up requirements. For instance, steam condensers or viscous liquid coolers at moderate temperatures should generally have the process stream introduced at or near the full flowrate. In contrast, process streams at high temperatures should be introduced to the exchanger gradually to minimize high thermal stresses that can cause mechanical failure.

**C.9.2.9** The fans should be turned on, the louvers and automatically controlled variable-pitch fans should be placed on automatic control, and the heating coil should be shut off when normal operating conditions are reached. Where steam coils directly below the process bundle are used in freezing climates, they should be drained immediately after start-up.

### **C.9.3 Shutdown Procedures**

**C.9.3.1** Before shutdown, the fans should be shut off, the louvers should be closed, and the heating coil, if provided, should be activated.

**C.9.3.2** The normal plant procedure for shutdown should be followed.

**C.9.3.3** If steam purging is required, caution should be exercised to ensure that the condensate is thoroughly drained.

**C.9.3.4** The heating coil should be turned off.

**C.9.3.5** The normal plant procedures for protecting the equipment during shutdown periods should be followed.

## **C.10 Sample Economic Comparison of Indirect (Tempered-water) Versus Direct Air Cooling for Systems Requiring Winterization**

### **C.10.1 General**

Before an economic comparison can be made between indirect and direct air-cooling for systems requiring winterization, it is necessary to select the operating temperatures for the tempered water. This is an important factor in the economics of the system. The outlet temperature,  $t_2$  (see Figure C.12), from the air-cooled heat exchanger is a function of the design dry-bulb air temperature and of the critical process and tube-wall temperatures in the shell-and-tube heat exchanger. Temperature  $t_1$  should be set above the critical process temperature. The temperature range,  $t_1 - t_2$ , affects the size of the tempered-water air-cooled heat exchanger, the shell-and-tube exchanger, and the circulating pump, and determines the number of shells in series. The temperature range should be selected to optimize the components for the particular system.

The conclusions of the example in C.10.2 and C.10.3 are specific for this application only. Each application should be investigated.

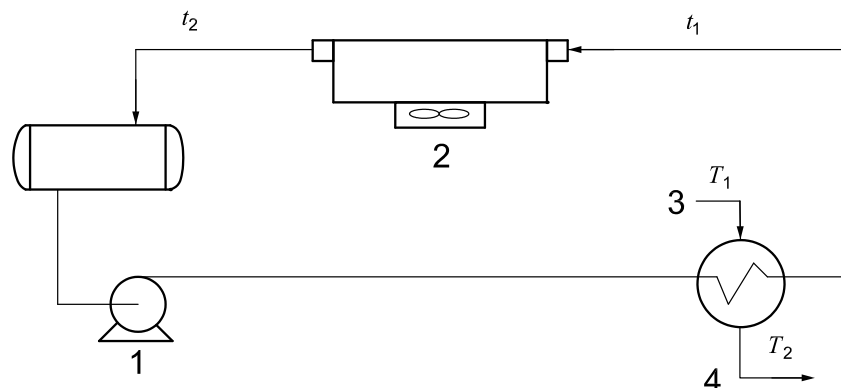
**Key**

- 1 circulating pump
- 2 water cooler
- 3 process fluid
- 4 process cooler

**Figure C.12 — Tempered-water System**

### C.10.2 Example (SI Units) <sup>7</sup>

A residuum cooler is designed to cool 363,000 kg/h of atmospheric residuum from 171 °C to 93 °C. The design dry-bulb air temperature is 49 °C, and the minimum design air temperature is 0 °C. The residuum pour point is 35 °C, and the inlet and outlet viscosities are 6.0 cP and 48.0 cP, respectively. The inlet and outlet temperatures of the circulating water were selected as 57 °C and 123 °C, respectively, giving a flowrate of 227,000 kg/h. Be aware that the problem selected is based on a pressurized water system. Table C.3 describes the two systems, and Table C.5 compares their costs.

The direct air-cooled heat exchanger system described in this subsection, although an actual application, might not represent the optimum design. In addition, the equipment costs given in this example are based on 1981 data and are for purposes of illustration only; when an actual economic comparison is made, current cost data should be used.

### C.10.3 Example (US Customary Units) <sup>7</sup>

A residuum cooler is designed to cool 800,000 lb/h of atmospheric residuum from 340 °F to 200 °F. The design dry-bulb air temperature is 120 °F, and the minimum design air temperature is 32 °F. The residuum pour point is 95 °F, and the inlet and outlet viscosities are 6.0 cP and 48 cP, respectively. The inlet and outlet temperatures of the circulating water were selected as 135 °F and 254 °F, respectively, giving a flowrate of 500,000 lb/h. Be aware that the problem selected is based on a pressurized water system. Table C.4 describes the two systems, and Table C.5 compares their costs.

The direct air-cooled heat exchanger system described in this subsection, although an actual application, might not represent the optimum design. In addition, the equipment costs given in this example are based on 1981 data and are for purposes of illustration only; when an actual economic comparison is made, current cost data should be used.

<sup>7</sup> Users of instructions should not rely exclusively on the information contained in this document. Sound business, scientific, engineering, and safety judgment should be used in employing the information contained herein. Where applicable, authorities having jurisdiction should be consulted. Work sites and equipment operations may differ. Users are solely responsible for assessing their specific equipment and premises in determining the appropriateness of applying the instructions. At all times users should employ sound business, scientific, engineering, and judgment safety when using this standard.

**Table C.3 — Description of Indirect and Direct Air Cooling Systems (SI Units)**

Item	Indirect System	Winterized Air-cooled Heat Exchanger
<b>Equipment</b>		
Shell-and-tube exchanger	1486 m <sup>2</sup>	—
Air-cooled heat exchanger	1208 m <sup>2</sup>	a
Pump	227 m <sup>3</sup> /h	—
Piping/surge tank	DN 150/1.89 m <sup>3</sup>	—
<b>Installation cost factors <sup>b</sup></b>		
Shell-and-tube exchanger	2.7	—
Air-cooled heat exchanger	1.8	1.8
Pump	2.5	—
Piping/surge tank	2.5	—
<b>Driver requirements</b>		
Air-cooled heat exchanger fans	111.9 kW	160.3 kW
Pump	18.6 kW	—
NOTE DN designates the nominal diameter.		
<p><sup>a</sup> The process duty of the winterized air-cooled heat exchanger is divided into two services, with a different exchanger configuration to handle each. Both configurations have full external recirculation and steam coils. For the 171.11 °C to 126.67 °C cooling range, the configuration consists of two bays 5.79 m wide and 9.14 m long, with two bundles per bay. Each bundle has five rows and 12 passes. The tubes have an outside diameter of 50.8 mm and have 394 aluminum fins (15.88 mm high) per meter. The tubes are in an equilateral triangular pattern and have a 101.6 mm pitch. The extended surface area is 12,289 m<sup>2</sup> (806 m<sup>2</sup> of bare tube surface area). For the 126.67 °C to 93.33 °C cooling range, the configuration consists of three parallel bays 4.88 m wide and 9.14 m long, with six bundles per bay. There are two parallel strings of three bundles in series. Each bundle has six rows and three passes. The tubes are bare, with an OD of 25.4 mm and a wall thickness of 2.77 mm. The tubes are in an equilateral triangular pattern and have a 44.45 mm transverse pitch. The surface area is 4133 m<sup>2</sup>.</p>		
<p><sup>b</sup> The installation cost factors may vary depending on location, labor costs, etc.</p>		

**Table C.4 — Description of Indirect and Direct Air Cooling Systems (US Customary Units)**

Item	Indirect System	Winterized Air-cooled Heat Exchanger
<b>Equipment</b>		
Shell-and-tube exchanger	16,000 ft <sup>2</sup>	—
Air-cooled heat exchanger	13,000 ft <sup>2</sup>	a
Pump	1000 gal/min	—
Piping/surge tank	NPS 6/500 gal	—
<b>Installation cost factors <sup>b</sup></b>		
Shell-and-tube exchanger	2.7	—
Air-cooled heat exchanger	1.8	1.8
Pump	2.5	—
Piping/surge tank	2.5	—
<b>Driver requirements</b>		
Air-cooled heat exchanger fans	150 brake hp	215 brake hp
Pump	25 brake hp	—
NOTE NPS designates the nominal pipe size.		
<p><sup>a</sup> The process duty of the winterized air-cooled heat exchanger is divided into two services, with a different exchanger configuration to handle each. Both configurations have full external recirculation and steam coils. For the 340 °F to 260 °F cooling range, the configuration consists of two bays 19 ft wide and 30 ft long, with two bundles per bay. Each bundle has five rows and 12 passes. The tubes have an outside diameter (OD) of 2 in. and have ten <sup>5</sup>/<sub>8</sub>-in.-high aluminum fins per inch. The tubes are in an equilateral triangular pattern and have a 1 in. transverse pitch. The extended surface area is 142,800 ft<sup>2</sup> (8671 ft<sup>2</sup> of bare tube surface area). For the 260 °F to 200 °F cooling range, the configuration consists of three parallel bays 16 ft wide and 30 ft long, with six bundles per bay. There are two parallel strings of three bundles in series. Each bundle has six rows and three passes. The tubes are bare, with an OD of 1 in. and a wall thickness of 0.109 in. The tubes are in an equilateral triangular pattern and have a 1 <sup>3</sup>/<sub>4</sub>-in. transverse pitch. The surface area is 44,485 ft<sup>2</sup>.</p>		
<p><sup>b</sup> The installation cost factors may vary depending on location, labor costs, etc.</p>		

**Table C.5 — Comparison of Costs of Indirect and Direct Air Cooling Systems**

Item	Indirect System (US Dollars)	Winterized Air-cooled Heat Exchanger (US Dollars)
<b>Equipment costs <sup>a</sup></b>		
Shell-and-tube exchanger	150,000	—
Air-cooled heat exchanger	287,000	1,136,000
Pump	10,000	—
Piping/surge tank	20,000	—
<b>Installed costs <sup>b</sup></b>		
Shell-and-tube exchanger	405,000	—
Air-cooled heat exchanger	516,000	2,045,000
Pump	25,000	—
Piping/surge tank	50,000	—
<b>Power costs <sup>c</sup></b>		
Air-cooled heat exchanger fans	225,000	322,000
Pump	37,000	—
<b>Evaluated total cost <sup>d</sup></b>		
System	1,258,000	2,367,000
<p><sup>a</sup> The equipment costs are based on 1981 data.</p> <p><sup>b</sup> The installed cost is obtained by multiplying the installation cost factor by the purchase price of the equipment in question. The cost includes associated piping, excavation, concrete, structural steel, electrical work, instrumentation, painting, and insulation.</p> <p><sup>c</sup> The electric power costs were calculated based on 1500 US dollars per brake horsepower (2011 US dollars per kilowatt).</p> <p><sup>d</sup> The evaluated total cost is equal to the sum of the installed costs and the power costs.</p>		

## C.11 Calculation of Minimum Tube-wall Temperature <sup>8</sup>

### C.11.1 Sample Calculation of Minimum Tube-wall Temperature for Finned Tubes (SI Units)

#### C.11.1.1 General

The forced-draught unit specified in C.11.1.2 is designed to cool 52,618 kg/h of gas oil product (with a gravity of 21.4° API and a UOP *K* of 11.5) from 143 °C to 71 °C, with an air inlet temperature of 32 °C. The designer desires to calculate the minimum tube-wall temperature at the outlet of the bottom row of tubes

<sup>8</sup> Users of instructions should not rely exclusively on the information contained in this document. Sound business, scientific, engineering, and safety judgment should be used in employing the information contained herein. Where applicable, authorities having jurisdiction should be consulted. Work sites and equipment operations may differ. Users are solely responsible for assessing their specific equipment and premises in determining the appropriateness of applying the instructions. At all times users should employ sound business, scientific, engineering, and judgment safety when using this standard.

for an air inlet temperature of  $-12\text{ }^{\circ}\text{C}$  and a minimum airflow of 66,679 kg/h, which is required to maintain the design process outlet temperature. The pour point of the gas oil is  $10\text{ }^{\circ}\text{C}$ .

### C.11.1.2 Unit Description

The unit consists of one bay containing one tube bundle that is 2.90 m long, with seven rows and seven passes. The bundle contains 319 carbon steel tubes with an outside diameter of 25.4 mm and a wall thickness of 2.77 mm, arranged in an equilateral triangular pattern on a 63.5 mm pitch. The tubes have 394 aluminum fins per meter; the fins are 15.9 mm high and 0.4 mm thick.

### C.11.1.3 Data

The variables for which values are given below are defined in C.5.2.

$$\begin{aligned}
 A_i & 0.0624 \text{ m}^2/\text{m} \\
 A_o & 1.68 \text{ m}^2/\text{m} \\
 f_a & 1.2 \\
 r_{fs} & 0.0593 \text{ m}^2\cdot\text{K}/\text{W} \\
 r_{ft} & 0.00685 \text{ m}^2\cdot\text{K}/\text{W} \\
 r_m & 0.00443 \text{ m}^2\cdot\text{K}/\text{W} \text{ (from Table C.6)} \\
 r_c & r_{ft} (A_o/A_i) + r_m + (r_{fs}/f_a) \\
 & 0.00685 (1.68/0.0624) + 0.00443 + (0.0593/1.2) \\
 & 0.238 \text{ m}^2\cdot\text{K}/\text{W} \\
 t_B & -12\text{ }^{\circ}\text{C} \\
 T_B & 71\text{ }^{\circ}\text{C} \\
 T_w & T_B - (r_{ft}/r_c) (A_o/A_i) (T_B - t_B) \\
 & 71 - (0.00685/0.238) (1.68/0.0624) [71 - (-12)] \\
 & 6.7\text{ }^{\circ}\text{C}
 \end{aligned}$$

The calculated tube-wall temperature is well below the recommended temperature of  $23.9\text{ }^{\circ}\text{C}$  ( $10\text{ }^{\circ}\text{C}$  plus  $13.9\text{ }^{\circ}\text{C}$  for the safety margin). Consequently, it is necessary that the designer consider a winterization method that adequately protects this design against pour-point problems. In this situation, systems C or D offer possible solutions to investigate; however, the designer decides to solve this problem in another way, as described in C.11.2.

**Table C.6 — Values for  $r_m$  Referred to the Total Outside Area for a Tube with an Outside Diameter of 25.4 mm and Aluminum Fins 15.9 mm High and 0.4 mm Thick**

Tube Material	$k^a$	No. of Fins per Meter	Tube Wall Thickness					
			mm					
			0.89	1.24	1.65	2.10	2.77	3.40
			$R_m$					
			m <sup>2</sup> ·K/W					
Admiralty	121	276	0.00295	0.00301	0.00307	0.00315	0.00326	0.00338
		315	0.00299	0.00306	0.00313	0.00321	0.00334	0.00342
		354	0.00303	0.00310	0.00318	0.00328	0.00342	0.00357
		394	0.00306	0.00314	0.00323	0.00333	0.00349	0.00366
		433	0.00309	0.00318	0.00327	0.00339	0.00356	0.00374
Aluminum	155.6	276	0.00291	0.00295	0.00300	0.00305	0.00313	0.00321
		315	0.00295	0.00299	0.00304	0.00310	0.00319	0.00329
		354	0.00298	0.00303	0.00309	0.00315	0.00325	0.00336
		394	0.00301	0.00306	0.00312	0.00320	0.00331	0.00342
		433	0.00303	0.00309	0.00316	0.00324	0.00336	0.00349
Carbon steel	45.0	276	0.00315	0.00329	0.00345	0.00364	0.00393	0.00422
		315	0.00322	0.00337	0.00356	0.00377	0.00410	0.00443
		354	0.00328	0.00345	0.00366	0.00390	0.00426	0.00463
		394	0.00334	0.00353	0.00376	0.00402	0.00443	0.00483
		433	0.00339	0.00360	0.00385	0.00414	0.00458	0.00503
Stainless steel (Types 302, 304, 316, 321, and 347)	16.08	276	0.00364	0.00399	0.00439	0.00486	0.00558	0.00631
		315	0.00377	0.00416	0.00462	0.00516	0.00597	0.00680
		354	0.00390	0.00434	0.00485	0.00545	0.00636	0.00729
		394	0.00403	0.00451	0.00508	0.00574	0.00674	0.00766
		433	0.00415	0.00467	0.00530	0.00602	0.00712	0.00824

NOTE The tabulated values are based on an assumed maximum air-side resistance ( $r_{fs}$ , or  $r_{fs} + r_{ds}$ ) of 0.0264. Assume fin efficiency  $\phi = 1$ .

<sup>a</sup>  $k$  is the thermal conductivity, in watts per (meter Kelvin).

## C.11.2 Sample Calculation of Minimum Tube-wall Temperature of Bare Tubes (SI Units)

### C.11.2.1 General

The designer decides to design the unit using both finned and bare tubes. The new design features a tube bundle with the upper rows of finned tubes and the lower rows of bare tubes. The amount of air at  $-12\text{ }^\circ\text{C}$  required to satisfy the design process outlet temperature of  $71\text{ }^\circ\text{C}$  is the same as for the design in C.11.1.1. The designer now calculates the minimum tube-wall temperature at the outlet of the bottom row of bare tubes.

### C.11.2.2 Unit Description

This unit consists of one bay containing one tube bundle that is 2.90 m wide and 9.14 m long, with eight rows and eight passes. The top six rows of the bundle contain 273 carbon steel tubes with an outside diameter of 25.4 mm and a wall thickness of 2.77 mm, arranged in an equilateral triangular pattern on a 63.5 mm pitch. These tubes have 394 aluminum fins per meter; the fins are 15.9 mm high and 0.4 mm

thick. In addition, the bundle contains 166 carbon steel bare tubes in the bottom two tube rows. These tubes also have an outside diameter of 25.4 mm and a wall thickness of 2.77 mm and are arranged in an equilateral triangular pattern on a 34.9 mm pitch.

### C.11.2.3 Data

The data for the bottom row of bare tubes are as follows.

$$A_b \quad 0.0798 \text{ m}^2/\text{m}$$

$$A_i \quad 0.0624 \text{ m}^2/\text{m}$$

$$r_{fs} \quad 0.0629 \text{ m}^2 \cdot \text{K}/\text{W}$$

$$r_{ft} \quad 0.0102 \text{ m}^2 \cdot \text{K}/\text{W}$$

$$r_{mt} \quad 0.000070 \text{ m}^2 \cdot \text{K}/\text{W}$$

$$r_c \quad r_{ft} (A_b/A_i) + r_{mt} + (r_{fs}/f_a)$$

$$0.0102 (0.0798/0.0624) + 0.000070 + (0.0269/1.2)$$

$$0.0355 \text{ m}^2 \cdot \text{K}/\text{W}$$

$$T_w \quad T_B - (r_{ft}/r_c) (A_b/A_i) (T_B - t_B)$$

$$71 - (0.0102/0.0355) (0.0798/0.0624) \times [71 - (-12)]$$

$$40.5 \text{ }^\circ\text{C}$$

$$r_{fs} \quad 0.059 \text{ m}^2 \cdot \text{K}/\text{W}$$

$$r_{ft} \quad 0.00415 \text{ m}^2 \cdot \text{K}/\text{W}$$

$$r_c \quad r_{ft} (A_o/A_i) + r_m + (r_{fs}/f_a)$$

$$0.00415 (1.68/0.0624) + 0.0044 + (0.059/1.2)$$

$$0.1653 \text{ m}^2 \cdot \text{K}/\text{W}$$

$$t_B \quad -0.4 \text{ }^\circ\text{C} \text{ (air temperature leaving the bare tube section)}$$

$$T_B \quad 78.5 \text{ }^\circ\text{C} \text{ (gas oil temperature leaving the sixth pass)}$$

$$T_w \quad T_B - (r_{ft}/r_c) (A_o/A_i) (T_B - t_B)$$

$$78.5 - (0.00415/0.1653) (1.68/0.0624) \times [78.5 - (-0.4)]$$

$$25.2 \text{ }^\circ\text{C} (> 23.9 \text{ }^\circ\text{C})$$

The calculated tube-wall temperature at the outlet of the bottom row of bare tubes is well above 23.9 °C, and no gas oil freeze-up is anticipated. To verify that the finned section of the bundle is also protected, the designer decides to calculate the tube-wall temperature at the outlet of the sixth pass (the row of finned tubes immediately above the bare tubes). From the thermal design calculations, the designer obtains the following data.

$$r_{fs} = 0.059 \text{ m}^2 \cdot \text{K/W}$$

$$r_{ft} = 0.00415 \text{ m}^2 \cdot \text{K/W}$$

$$r_c = r_{ft} (A_o/A_i) + r_m + (r_{fs}/f_a)$$

$$0.00415 (1.68/0.0624) + 0.0044 + (0.059/1.2)$$

$$0.1653 \text{ m}^2 \cdot \text{K/W}$$

$$t_B = -0.4 \text{ }^\circ\text{C} \text{ (air temperature leaving the bare tube section)}$$

$$T_B = 78.5 \text{ }^\circ\text{C} \text{ (gas oil temperature leaving the sixth pass)}$$

$$T_w = T_B - (r_{ft}/r_c) (A_o/A_i) (T_B - t_B)$$

$$78.5 - (0.00415/0.1653) (1.68/0.0624) \times [78.5 - (-0.4)]$$

$$25.2 \text{ }^\circ\text{C} (> 23.9 \text{ }^\circ\text{C})$$

It appears that this design is safe against a potential freeze-up for continuous operation. As in all viscous fluid coolers, however, an auxiliary heating coil is recommended for cold start-up.

### C.11.3 Sample Calculation of Minimum Tube-wall Temperature for Finned Tubes (US Customary Units)

#### C.11.3.1 General

The forced-draught unit specified in C.11.3.2 is designed to cool 116,000 lb/h of gas oil product (with a gravity of 21.4° API and a UOP  $K$  of 11.5) from 290 °F to 160 °F, with an air inlet temperature of 90 °F. The designer desires to calculate the minimum tube-wall temperature at the outlet of the bottom row of tubes for an air inlet temperature of 10 °F and a minimum airflow of 147,000 lb/h, which is required to maintain the design process outlet temperature. The pour point of the gas oil is 50 °F.

#### C.11.3.2 Unit Description

The unit consists of one bay containing one tube bundle that is 9.5 ft wide and 30 ft long, with seven rows and seven passes. The bundle contains 319 carbon steel tubes with an outside diameter of 1 in. and a wall thickness of 0.109 in., arranged in an equilateral triangular pattern on a 2.5 in. pitch. The tubes have 10 aluminum fins per in.; the fins are  $\frac{5}{8}$  in. high and 0.016 in. thick.

#### C.11.3.3 Data

The variables for which values are given below are defined in C.5.2.

$$A_i = 0.2047 \text{ ft}^2/\text{ft}$$

$$A_o = 5.5 \text{ ft}^2/\text{ft}$$

$$f_a = 1.2$$

$$\begin{aligned}
 r_{fs} &= 0.3367 \text{ (}^\circ\text{F)(ft}^2\text{)(h)/Btu} \\
 r_{ft} &= 0.0389 \text{ (}^\circ\text{F)(ft}^2\text{)(h)/Btu} \\
 r_m &= 0.0251 \text{ Btu}^{-1} \text{ (from Table C.7)} \\
 r_c &= r_{ft} (A_o/A_i) + r_m + (r_{fs}/f_a) \\
 &= 0.0389 (5.5/0.2047) + 0.0251 + (0.3367/1.2) \\
 &= 1.351 \text{ (}^\circ\text{F)(ft}^2\text{)(h)/Btu} \\
 t_B &= 10 \text{ }^\circ\text{F} \\
 T_B &= 160 \text{ }^\circ\text{F} \\
 T_w &= T_B - (r_{ft}/r_c) (A_o/A_i) (T_B - t_B) \\
 &= 160 - (0.0389/1.351) (5.5/0.2047) (160 - 10) \\
 &= 44 \text{ }^\circ\text{F}
 \end{aligned}$$

The calculated tube-wall temperature is well below the recommended temperature of 75 °F (50 °F plus 25 °F for the safety margin). Consequently, it is necessary that the designer consider a winterization method that adequately protects this design against pour-point problems. In this situation, systems C or D offer possible solutions to investigate; however, the designer decides to solve this problem in another way, as described in C.11.4.

### C.11.4 Sample Calculation of Minimum Tube-wall Temperature of Bare Tubes (US Customary Units)

#### C.11.4.1 General

The designer decides to design the unit using both finned and bare tubes. The new design features a tube bundle with the upper rows of finned tubes and the lower rows of bare tubes. The amount of air at 10 °F required to satisfy the design process outlet temperature of 160 °F is the same as for the design in C.11.3.1. The designer now calculates the minimum tube-wall temperature at the outlet of the bottom row of bare tubes.

#### C.11.4.2 Unit Description

The unit consists of one bay containing one tube bundle that is 9.5 ft wide and 30 ft long, with eight rows and eight passes. The top six rows of the bundle contain 273 carbon steel tubes with an outside diameter of 1 in. and a wall thickness of 0.109 in., arranged in an equilateral triangular pattern on a 2.5 in. pitch. These tubes have 10 aluminum fins per in.; the fins are  $\frac{5}{8}$  in. high and 0.016 in. thick. In addition, the bundle contains 166 carbon steel bare tubes in the bottom two tube rows. These tubes also have an outside diameter of 1 in. and a wall thickness of 0.109 in. and are arranged in an equilateral triangular pattern on a  $1\frac{3}{8}$  in. pitch.

**Table C.7 — Values for  $r_m$  Referred to the Total Outside Area for a Tube with an Outside Diameter of 1 in. and Aluminum Fins  $\frac{5}{8}$  in. High and 0.016 in. Thick**

Tube Material	$k^a$	No. of Fins per in.	Tube Wall Thickness (in.)					
			0.035	0.049	0.065	0.083	0.109	0.134
			$R_m$ (°F·ft <sup>2</sup> ·h/Btu)					
Admiralty	70	7	0.01677	0.01708	0.01745	0.01787	0.01852	0.01918
		8	0.01700	0.01735	0.01777	0.01825	0.01898	0.01943
		9	0.01720	0.01760	0.01806	0.01860	0.01942	0.02025
		10	0.01739	0.01782	0.01833	0.01893	0.01984	0.02076
		11	0.01755	0.01803	0.01859	0.01925	0.02024	0.02125
Aluminum	90	7	0.01655	0.01677	0.01702	0.01732	0.01778	0.01824
		8	0.01675	0.01700	0.01729	0.01763	0.01814	0.01866
		9	0.01692	0.01720	0.01752	0.01790	0.01848	0.01906
		10	0.01708	0.01738	0.01774	0.01816	0.01879	0.01944
		11	0.01722	0.01755	0.01794	0.01840	0.01909	0.01980
Carbon steel	26	7	0.01789	0.01867	0.01959	0.02067	0.02230	0.02396
		8	0.01827	0.01916	0.02020	0.02142	0.02327	0.02515
		9	0.01862	0.01961	0.02078	0.02214	0.02421	0.02631
		10	0.01896	0.02005	0.02134	0.02285	0.02513	0.02745
		11	0.01927	0.02047	0.02188	0.02353	0.02603	0.02858
Stainless steel (Types 302, 304, 316, 321, and 347)	9.3	7	0.02068	0.02263	0.02493	0.02762	0.03169	0.03584
		8	0.02143	0.02364	0.02625	0.02930	0.03392	0.03862
		9	0.02215	0.02463	0.02755	0.03095	0.03611	0.04137
		10	0.02286	0.02559	0.02882	0.03258	0.03829	0.04409
		11	0.02355	0.02654	0.03008	0.03420	0.04045	0.04681

NOTE The tabulated values are based on an assumed maximum air-side resistance ( $r_{fs}$ , or  $r_{fs} + r_{ds}$ ) of 0.15. Assume fin efficiency  $\phi = 1$ .

<sup>a</sup>  $k$  is the thermal conductivity, in British thermal units (hour) (square foot) (degree Fahrenheit) per foot.

### C.11.4.3 Data

The data for the bottom row of bare tubes are as follows.

$$A_b = 0.2618 \text{ ft}^2/\text{ft}$$

$$A_i = 0.2047 \text{ ft}^2/\text{ft}$$

$$r_{fs} = 0.153 \text{ (}^\circ\text{F)(ft}^2\text{)(h)/Btu}$$

$$r_{ft} = 0.058 \text{ (}^\circ\text{F)(ft}^2\text{)(h)/Btu}$$

$$r_{mt} = 0.0004 \text{ (}^\circ\text{F)(ft}^2\text{)(h)/Btu}$$

$$r_c = r_{ft} (A_b/A_i) + r_{mt} + (r_{fs}/f_a)$$

$$0.058 (0.2618/0.2047) + 0.0004 + (0.153/1.2)$$

$$0.202 \text{ (}^\circ\text{F)(ft}^2\text{)(h)/Btu}$$

$$T_w = T_B - (r_{ft}/r_c) (A_b/A_i) (T_B - t_B)$$

$$160 - (0.058/0.202) (0.2618/0.2047) (160 - 10)$$

$$105 \text{ }^\circ\text{F}$$

$$r_{fs} = 0.3356 \text{ (}^\circ\text{F)(ft}^2\text{)(h)/Btu}$$

$$r_{ft} = 0.0236 \text{ (}^\circ\text{F)(ft}^2\text{)(h)/Btu}$$

$$r_c = r_{ft} (A_o/A_i) + r_m + (r_{fs}/f_a)$$

$$0.0236 (5.5/0.2047) + 0.0251 + (0.3356/1.2)$$

$$0.939 \text{ (}^\circ\text{F)(ft}^2\text{)(h)/Btu}$$

$$t_B = 31.3 \text{ }^\circ\text{F (air temperature leaving the bare tube section)}$$

$$T_B = 173.4 \text{ }^\circ\text{F (gas oil temperature leaving the sixth pass)}$$

$$T_w = T_B - (r_{ft}/r_c) (A_o/A_i) (T_B - t_B)$$

$$173.4 - (0.0236/0.939) (5.5/0.2047) \times (173.4 - 31.3)$$

$$77.4 \text{ }^\circ\text{F (} > 75 \text{ }^\circ\text{F)}$$

The calculated tube-wall temperature at the outlet of the bottom row of bare tubes is well above 75 °F, and no gas oil freeze-up is anticipated. To verify that the finned section of the bundle is also protected, the designer decides to calculate the tube-wall temperature of the outlet of the sixth pass (the row of finned tubes immediately above the bare tubes). From the thermal design calculations, the designer obtains the following data.

$$r_{fs} = 0.3356 \text{ (}^\circ\text{F)(ft}^2\text{)(h)/Btu}$$

$$r_{ft} = 0.0236 \text{ (}^\circ\text{F)(ft}^2\text{)(h)/Btu}$$

$$r_c = r_{ft} (A_o/A_i) + r_m + (r_{fs}/f_a)$$

$$0.0236 (5.5/0.2047) + 0.0251 + (0.3356/1.2)$$

$$0.939 \text{ (}^\circ\text{F)(ft}^2\text{)(h)/Btu}$$

$$t_B = 31.3 \text{ }^\circ\text{F (air temperature leaving the bare tube section)}$$

$$T_B = 173.4 \text{ }^\circ\text{F (gas oil temperature leaving the sixth pass)}$$

$$T_w = T_B - (r_{ft}/r_c) (A_o/A_i) (T_B - t_B)$$

$$173.4 - (0.0236/0.939) (5.5/0.2047) \times (173.4 - 31.3)$$

$$77.4 \text{ }^\circ\text{F (} > 75 \text{ }^\circ\text{F)}$$

It appears that this design is safe against a potential freeze-up for continuous operation. As in all viscous fluid coolers, however, an auxiliary heating coil is recommended for cold start-up.

## C.12 Sample Calculation of Heat Losses <sup>9</sup>

### C.12.1 Sample Calculation of Heat Losses (SI Units)

#### C.12.1.1 General

In the examples in C.12.1, it is necessary to establish the temperature differential between the ambient air and the enclosed air. In the calculation determining the minimum heat-input requirement for an auxiliary heating coil, the temperature of the air enclosed in the plenum surrounding the process coil should be the temperature to which it is desired to warm the process bundle.

Within a heated enclosure, air near the top is hotter than air near the bottom. An inside air temperature is assumed for the top of the enclosure as well as the bottom. These assumed air temperatures are not recommended air temperatures, but are simply assumed values used to illustrate the calculation procedure.

Be aware that the louver area is assumed to be the same as the face area of the tube bundle; this is not always the case.

---

<sup>9</sup> Users of instructions should not rely exclusively on the information contained in this document. Sound business, scientific, engineering, and safety judgment should be used in employing the information contained herein. Where applicable, authorities having jurisdiction should be consulted. Work sites and equipment operations may differ. Users are solely responsible for assessing their specific equipment and premises in determining the appropriateness of applying the instructions. At all times users should employ sound business, scientific, engineering, and judgment safety when using this standard.

### C.12.1.2 Nomenclature

#### C.12.1.2.1 Symbols

$A_l$	louver leakage area, in square meters. (In the calculations below, $A_l$ is assumed to be 2 % of the tube bundle face area.)
$c_p$	average specific heat capacity, in kJ/(kg·K) (taken as 1.005 for air)
$F_p$	pressure promoting leakage, in meters of fluid
$g$	acceleration due to gravity, equal to 9.807 m/s <sup>2</sup>
$h$	height of the hot air column, in meters
$K$	local heat transfer coefficient, in W/(m <sup>2</sup> ·K)
$\phi$	heat loss per unit time, in W
$R$	gas constant, in J/(mol·K)
$T$	temperature, in °C
$U$	thermal transmittance, in W/(m <sup>2</sup> ·K)
$v$	velocity, in m/s
$q_m$	flow per unit time, in kg/h
$\rho$	density of air, in kg/m <sup>3</sup>

#### C.12.1.2.2 Subscripts

- o relating to conditions outside the air-cooled heat exchanger
- l relating to conditions inside the air-cooled heat exchanger

### C.12.1.3 Louver Leakage

**C.12.1.3.1** Air that is warmer than ambient air and is contained in an unsealed enclosure tries to rise within that enclosure and exerts a pressure on the upper surface. This causes leakage when the upper surface consists of non-sealing louver blades. The pressure promoting leakage may be expressed as given in Equation (C.9):

$$F_p = [h(\rho_o - \rho_l)]/\rho_l \quad (\text{C.9})$$

The velocity through the leak areas (assuming a loss of 1.5 velocity heads) is as given in Equation (C.10):

$$v = (2gF_p / 1.5)^{1/2} \quad (\text{C.10})$$

The rate at which warm air leaks through the louvers is as given in Equation (C.11):

$$q_m = 3600 v \rho_i A_i \quad (\text{C.11})$$

The rate of heat loss due to louver leakage is as given in Equation (C.12):

$$\phi = q_m c_p (T_i - T_o) \quad (\text{C.12})$$

A sample calculation of heat loss due to louver leakage is presented in C.12.1.3.2.

**C.12.1.3.2** Assume the following conditions: A totally enclosed air-cooled heat exchanger is 4.27 m wide, 10.97 m long, and 2.44 m high. The inside air temperature  $T_i$  is 37.78 °C, and the outside air temperature  $T_o$  is -17.78 °C. Assuming that the perfect-gas laws apply, the air density can be determined from Equation (C.13):

$$\rho = (Mp)/(RT) \quad (\text{C.13})$$

where

$M$  is relative molecular mass of air, equal to 28.96;

$p$  is the absolute pressure, in kilopascal;

$R$  is the gas constant, equal to 8.31 J/(mol·K);

$T$  is temperature, in degrees Kelvin.

Therefore, the outside air density is:

$$\begin{aligned} \rho_o &= [(28.96) (101.33)] / [(8.31) (-17.78 + 273.15)] \\ &= 1.383 \text{ kg/m}^3 \end{aligned}$$

The inside air density is:

$$\begin{aligned} \rho_i &= [(28.96) (101.33)] / [(8.31) (37.78 + 273.15)] \\ &= 1.136 \text{ kg/m}^3 \end{aligned}$$

The pressure promoting leakage through the louvers is determined using Equation (C.9) as follows:

$$\begin{aligned} F_p &= [h(\rho_o - \rho_i)] / \rho_i \\ &= [2.44 (1.383 - 1.136)] / 1.136 \\ &= 0.531 \text{ m of air.} \end{aligned}$$

The velocity through the louver leakage area resulting from this pressure is calculated using Equation (C.10) as follows:

$$\begin{aligned} v &= (2gF_p/1.5)^{1/2} \\ &= [(2) (9.807) (0.531)/1.5]^{1/2} \\ &= 2.63 \text{ m/s.} \end{aligned}$$

The air leakage rate through the louvers is calculated using Equation (C.11) as follows:

$$\begin{aligned} q_m &= 3600 v \rho_i A_i \\ &= (3600) (2.63) (1.136) [(0.02) (4.27) (10.97)] \\ &= 10,076 \text{ kg/h.} \end{aligned}$$

The rate of heat loss resulting from louver leakage is then determined using Equation (C.12) as follows:

$$\begin{aligned} \phi &= q_m c_p (T_i - T_o) \\ &= (10,076) [(1.005) (1000/3600)] [37.78 - (-17.78)] \\ &= 156,300 \text{ W.} \end{aligned}$$

#### C.12.1.4 Surface Heat Loss

**C.12.1.4.1** The heat lost by convection from the exterior surfaces of the plenum is a function of temperature difference, wind velocity, and surface area. For velocities less than 4.88 m/s, Equation (C.14) from Reference [13] is recommended for determining the heat transfer coefficient for airflow parallel to flat surfaces:

$$K = 7.88 + 0.21v \quad (\text{C.14})$$

NOTE This equation is derived for vertical surfaces; for simplicity, however, it is used here for all surfaces, since the majority is vertical.

For velocities of 4.88 m/s and higher, the Equation (C.15) is recommended:

$$K = 7.17(v)^{0.78} \quad (\text{C.15})$$

A sample calculation of heat loss by convection from an air-cooled heat exchanger is presented in C.12.1.4.2.

**C.12.1.4.2** Assume the following conditions: A totally enclosed air-cooled heat exchanger is 5.49 m wide, 10.97 m long, and 4.88 m high (from grade to the top of the louvers). The inside air temperature varies linearly from 37.78 °C at the top to 10.0 °C at the bottom. The outside air temperature is -17.78 °C. The inside air velocity is 0.61 m/s. The outside wind velocity is 9.14 m/s.

The thermal transmittance,  $U$ , is calculated as follows:

$$\begin{aligned} K_i &= 7.88 + 0.21v \\ &= 7.88 + (0.21) (0.61) \\ &= 8.01 \text{ W/m}^2\cdot\text{K} \\ K_o &= 7.17 (v)^{0.78} \\ &= 7.17 (9.14)^{0.78} \\ &= 40.26 \text{ W/m}^2\cdot\text{K} \\ U &= 1/[(1/K_i) + (1/K_o)] \\ &= 1/[(1/8.01) + (1/40.26)] \\ &= 6.68 \text{ W/m}^2\cdot\text{K} \end{aligned}$$

The total surface heat loss is determined as follows:

$$\begin{aligned}\phi &= UA (T_i - T_o) \\ &= 6.68 \{[(5.49) (10.97)] [37.78 - (-17.78)] + [(4.88) (5.49 + 5.49 + 10.97 + 10.97)] [(37.78 + 10)/2 - (-17.78)]\} \\ &= 67,000 \text{ W}\end{aligned}$$

### C.12.1.5 Total Heat Loss Calculation

#### C.12.1.5.1 Forced Draught with External Recirculation

Assume that an enclosure is 5.49 m wide, 10.97 m long, and 5.49 m high. The dimensions of the top louver area are 4.27 m by 10.97 m. Inlet air louvers are located on the sides near the bottom. There is a hot air column that is 2.74 m high between the heating coil and the top louvers. Assume an outside air temperature of  $-17.78^\circ\text{C}$  and an inside air temperature that varies linearly from  $37.78^\circ\text{C}$  above the heating coil to  $10.0^\circ\text{C}$  at the bottom of the enclosure.

The heat loss through the top louvers may be calculated as follows:

$$\begin{aligned}\rho_o &= 1.383 \text{ kg/m}^3 \\ \rho_i &= 1.136 \text{ kg/m}^3\end{aligned}$$

The pressure promoting leakage resulting from the effect of the hot air column above the heating coil is determined as follows:

$$\begin{aligned}F_{p1} &= [h(\rho_o - \rho_i)] / \rho_i \\ &= [2.74 (1.383 - 1.136)] / 1.136 \\ &= 0.596 \text{ m of air}\end{aligned}$$

The air density at the average temperature below the heating coil is

$$\begin{aligned}\rho_i &= (Mp)/(RT) \\ &= [(28.96) (101.33)] \div \{(8.31) [(37.78 + 10.0)/2 + 273.15]\} \\ &= 1.189 \text{ kg/m}^3\end{aligned}$$

The pressure promoting leakage below the heating coil is determined by

$$\begin{aligned}F_{p2} &= [h(\rho_o - \rho_i)] / \rho_i \\ &= [2.74 (1.383 - 1.189)] / 1.189 \\ &= 0.447 \text{ m of air}\end{aligned}$$

The total pressure promoting leakage is the sum of the pressures above and below the heating coil:

$$\begin{aligned}F_{pd} &= F_{p1} + F_{p2} \\ &= 0.596 + 0.447 \\ &= 1.043 \text{ m of air}\end{aligned}$$

This pressure drop, however, assumes no restriction of the inlet air to the exchanger. Since the entire exchanger is enclosed, it is necessary that the entering air come through the inlet louvers. It is necessary that the quantity of inlet air equal the quantity of exhaust air. It can be assumed that the effective pressure promoting leakage,  $F_p^*$ , is equally divided between the inlet and the exhaust louvers. Therefore,

$$F_p^* = 1.043/2$$

$$= 0.522 \text{ m of air}$$

The velocity through the louver leak area is

$$v = (2gF_p^*/1.5)^{1/2}$$

$$= [(2) (9.807) (0.522)/1.5]^{1/2}$$

$$= 2.61 \text{ m/s}$$

The rate of heat loss resulting from louver leakage is then

$$\phi = q_m c_p (T_i - T_o)$$

$$= [(3600) (2.61) (1.136)] [(0.02) (4.27) (10.97)] \times [(1.005) (1000/3600)] [37.78 - (-17.78)]$$

$$= 155,100 \text{ W}$$

The thermal transmittance,  $U$ , is  $6.68 \text{ W/m}^2\cdot\text{K}$ . The rate of surface heat loss is

$$\phi = UA (T_i - T_o)$$

$$= 6.68 (2.74) (5.49 + 5.49 + 10.97 + 10.97) \times [37.78 - (-17.78)] + \dots$$

$$\dots + 6.68 (2.74) (5.49 + 5.49 + 10.97 + 10.97) \times [(37.78 + 10.0)/2 - (-17.78)] + \dots$$

$$\dots + 6.68 [(5.49) (10.97)] [(37.78 - (-17.78))]$$

$$= 80,900 \text{ W.}$$

### C.12.1.5.2 Forced Draught Without Louvers

This case is discussed to show that heat loss is from four to eight times greater without top louvers than when louvers are present. This loss is caused by an unimpeded natural draught of air through the tube bundle. Under such conditions it is reasonable to assume an air velocity of  $15.24 \text{ m/min}$  at the bundle face. Assume the following air-cooled heat exchanger geometry, as used in the example in C.12.1.3: A totally enclosed air-cooled heat exchanger is  $4.27 \text{ m}$  wide,  $10.97 \text{ m}$  long, and  $2.44 \text{ m}$  high. Also assume that the air is heated from  $-17.78 \text{ }^\circ\text{C}$  to  $37.78 \text{ }^\circ\text{C}$ .

The heat loss is calculated as follows.

The rate of warm air loss through the bundle is

$$q_m = 3600 v \rho_i A$$

$$= (3600) (15.24/60) (1.136) [(4.27) (10.97)]$$

$$= 48,700 \text{ kg/h}$$

This leads to the following rate of heat loss:

$$\phi = q_m c_p (T_i - T_o)$$

$$= (48,700) [(1.005) (1000/3600)] [(37.78 - (-17.78))]$$

$$= 754,700 \text{ W}$$

For other designs that can require analysis, it is recommended that the principles shown in these examples be applied.

## C.12.2 Sample Calculation of Heat Losses (US Customary Units)

### C.12.2.1 General

In the examples in C.12.2, it is necessary to establish the temperature differential between the ambient air and the enclosed air. In the calculation determining the minimum heat input requirement for an auxiliary heating coil, the temperature of the air enclosed in the plenum surrounding the process coil should be the temperature to which it is desired to warm the process bundle.

Within a heated enclosure, air near the top is hotter than air near the bottom. An inside air temperature is assumed for the top of the enclosure as well as the bottom. These assumed air temperatures are not recommended air temperatures, but are simply assumed values used to illustrate the calculation.

Be aware that the louver area is assumed to be the same as the face area of the tube bundle; this is not always the case.

### C.12.2.2 Nomenclature

#### C.12.2.2.1 Symbols

$A_l$	louver leakage area, in square feet. (In the calculations below, $A_l$ is assumed to be 2 % of the tube bundle face area.)
$c_p$	average specific heat capacity, in British thermal units per (pound) (degrees Fahrenheit) (taken as 0.24 for air)
$F_p$	pressure promoting leakage, in feet of fluid
$g$	acceleration due to gravity, equal to 32.17 ft/s <sup>2</sup>
$h$	height of the hot air column, in feet
$K$	local heat transfer coefficient, in British thermal units per (hour) (square foot) (degrees Fahrenheit)
$\phi$	heat loss per unit time, in British thermal units per hour
$R$	gas constant, in (cubic feet) (pounds per square in. absolute) per (pound-mole) (degrees Rankine)
$T$	temperature, in degrees Fahrenheit
$U$	thermal transmittance, in British thermal units per (hour) (square foot) (degrees Fahrenheit)
$v$	velocity, in feet per second
$q_m$	flow per unit time, in pounds per hour
$\rho$	density of air, in pounds per cubic foot

### C.12.2.2.2 Subscripts

- o relating to conditions outside the air-cooled heat exchanger
- i relating to conditions inside the air-cooled heat exchanger

### C.12.2.3 Louver Leakage

**C.12.2.3.1** Air that is warmer than ambient air and is contained in an unsealed enclosure tries to rise within that enclosure and exerts a pressure on the upper surface. This causes leakage when the upper surface consists of non-sealing louver blades. The pressure promoting leakage may be expressed as follows:

$$F_p = [h(\rho_o - \rho_i)] / \rho_i \quad (\text{C.16})$$

The velocity through the leak areas (assuming a loss of 1.5 velocity heads) is

$$v = (2gF_p / 1.5)^{1/2} \quad (\text{C.17})$$

The rate at which warm air leaks through the louvers is

$$q_m = 3600 v \rho_i A_i \quad (\text{C.18})$$

The rate of heat loss due to louver leakage is

$$\phi = q_m c_p (T_i - T_o) \quad (\text{C.19})$$

A sample calculation of heat loss due to louver leakage is presented in C.12.2.3.2.

**C.12.2.3.2** Assume the following conditions: A totally enclosed air-cooled heat exchanger is 14 ft wide, 36 ft long, and 8 ft high. The inside air temperature  $T_i$  is 100 °F, and the outside air temperature  $T_o$  is 0 °F. Assuming that the perfect-gas laws apply, the air density can be determined from Equation (C.20):

$$\rho = (Mp) / (RT) \quad (\text{C.20})$$

where

$M$  is the relative molecular mass of air, equal to 28.96;

$p$  is the pressure, in pounds per square in. absolute;

$R$  is the gas constant, equal to 10.73 (cubic feet) (pounds per square in. absolute) per (pound-mole) (degrees Rankine);

$T$  is air temperature, in degrees Rankine.

Therefore, the outside air density is

$$\begin{aligned} \rho_o &= [(28.96) (14.70)] / [(10.73) (0 + 459.67)] \\ &= 0.0863 \text{ lb/ft}^3 \end{aligned}$$

The inside air density is

$$\begin{aligned}\rho_i &= [(28.96) (14.70)] / [(10.73) (100 + 459.67)] \\ &= 0.0709 \text{ lb/ft}^3\end{aligned}$$

The pressure promoting leakage through the louvers is determined using Equation (C.16) as follows:

$$\begin{aligned}F_p &= [h(\rho_o - \rho_i)] / \rho_i \\ &= [8 (0.0863 - 0.0709)] / 0.0709 \\ &= 1.738 \text{ ft of air}\end{aligned}$$

The velocity through the louver leakage area resulting from this pressure is calculated using Equation (C.17) as follows:

$$\begin{aligned}v &= (2gF_p/1.5)^{1/2} \\ &= [(2) (32.17) (1.738)/1.5]^{1/2} \\ &= 8.63 \text{ ft/s}\end{aligned}$$

The air leakage rate through the louvers is calculated using equation (C.18) as follows:

$$\begin{aligned}q_m &= 3600 v \rho_i A_i \\ &= (3600) (8.63) (0.0709) [(0.02) (14) (36)] \\ &= 22.203 \text{ lb/h}\end{aligned}$$

The rate of heat loss resulting from louver leakage is then determined using Equation (C.19) as follows:

$$\begin{aligned}\phi &= q_m c_p (T_i - T_o) \\ &= (22,203) (0.24) (100 - 0) \\ &= 532,900 \text{ Btu/h.}\end{aligned}$$

#### C.12.2.4 Surface Heat Loss

**C.12.2.4.1** The heat lost by convection from the exterior surfaces of the plenum is a function of temperature difference, wind velocity, and surface area. For velocities less than 16 ft/s, the following equation from Reference [13] is recommended for determining the heat transfer coefficient,  $K$ , for airflow parallel to flat surfaces:

$$K = 0.99 + 0.21v \tag{C.21}$$

NOTE This equation is derived for vertical surfaces; for simplicity, however, it is used here for all surfaces, since most are vertical.

For velocities of 16 ft/s and higher, Equation (C.22) is recommended:

$$K = 0.5 (v)^{0.78} \tag{C.22}$$

A sample calculation of heat loss by convection from an air-cooled heat exchanger is presented in C.12.2.4.2.

**C.12.2.4.2** Assume the following conditions: A totally enclosed air-cooled heat exchanger is 18 ft wide, 36 ft long, and 16 ft high (from grade to the top of the louvers). The inside air temperature varies linearly from 100 °F at the top to 50 °F at the bottom. The outside air temperature is 0 °F. The inside air velocity is 2 ft/s. The outside wind velocity is 30 ft/s.

The thermal transmittance,  $U$ , is calculated as follows:

$$\begin{aligned} K_i &= 0.99 + 0.21v \\ &= 0.99 + (0.21) (2) \\ &= 1.41 \text{ Btu}/(\text{h}\cdot\text{ft}^2\cdot^\circ\text{F}). \end{aligned}$$

$$\begin{aligned} K_o &= 0.5 (v)^{0.78} \\ &= 0.5 (30)^{0.78} \\ &= 7.09 \text{ Btu}/(\text{h}\cdot\text{ft}^2\cdot^\circ\text{F}). \end{aligned}$$

$$\begin{aligned} U &= 1/[(1/K_i) + (1/K_o)] \\ &= 1/[(1/1.41) + (1/7.09)] \\ &= 1.176 \text{ Btu}/(\text{h}\cdot\text{ft}^2\cdot^\circ\text{F}). \end{aligned}$$

The total surface heat loss rate is determined as follows:

$$\begin{aligned} \phi &= UA (T_i - T_o) \\ &= (1.17) \{ (18) (36) (100 - 0) + (16) (18 + 18 + 36 + 36) [(100 + 50)/2 - 0] \} \\ &= 227,400 \text{ Btu/h}. \end{aligned}$$

### C.12.2.5 Total Heat Loss Calculation

#### C.12.2.5.1 Forced Draught with External Recirculation

Assume that an enclosure is 18 ft wide, 36 ft long, and 18 ft high. The dimensions of the top louver area are 14 ft by 36 ft. Inlet air louvers are located on the sides near the bottom. There is a hot air column that is 9 ft high between the heating coil and the top louvers. Assume an outside air temperature of 0 °F and an inside air temperature that varies linearly from 100 °F above the heating coil to 50 °F at the bottom of the enclosure.

The heat loss through the top louvers may be calculated as follows:

$$\begin{aligned} \rho_o &= 0.0863 \text{ lb}/\text{ft}^3 \\ \rho_i &= 0.0709 \text{ lb}/\text{ft}^3 \end{aligned}$$

The pressure promoting leakage resulting from the effect of the hot-air column above the heating coil is determined as follows:

$$\begin{aligned} F_{p1} &= [h(\rho_o - \rho_i)] / \rho_i \\ &= [(9) (0.0863 - 0.0709)] / 0.0709 \\ &= 1.95 \text{ ft of air}. \end{aligned}$$

The air density at the average temperature below the heating coil is

$$\begin{aligned} \rho_i &= (Mp)/(RT_i) \\ &= [(28.96) (14.7)] \div \{ (10.73) [(100 + 50)/2 + 459.67] \} \\ &= 0.0742 \text{ lb}/\text{ft}^3. \end{aligned}$$

The pressure promoting leakage below the heating coil is determined by

$$\begin{aligned} F_{p2} &= [h(\rho_o - \rho_i)] / \rho_i \\ &= [9 (0.0863 - 0.0742)] / 0.0742 \\ &= 1.47 \text{ ft of air.} \end{aligned}$$

The total pressure promoting leakage is the sum of the pressures above and below the heating coil:

$$\begin{aligned} F_{pd} &= F_{p1} + F_{p2} \\ &= 1.95 + 1.47 \\ &= 3.42 \text{ ft of air.} \end{aligned}$$

This pressure drop, however, assumes no restriction of the inlet air to the exchanger. Since the entire exchanger is enclosed, it is necessary that the entering air come through the inlet louvers. It is necessary that the quantity of inlet air equal the quantity of exhaust air. It can be assumed that the effective pressure promoting leakage,  $F_p^*$  is equally divided between the inlet and exhaust louvers. Therefore

$$\begin{aligned} F_p^* &= 3.42/2 \\ &= 1.71 \text{ ft of air} \end{aligned}$$

The velocity through the louver leak area is

$$\begin{aligned} v &= (2gF_p^*/1.5)^{1/2} \\ &= [(2) (32.17) (1.71)/1.5]^{1/2} \\ &= 8.56 \text{ ft/s} \end{aligned}$$

The heat loss resulting from louver leakage is, then,

$$\begin{aligned} \phi &= q_m c_p (T_i - T_o) \\ &= [(3600) (8.56) (0.0709)] [(0.02) (14) (36)] [(0.24) (100 - 0)] \\ &= 528,600 \text{ Btu/h} \end{aligned}$$

The thermal transmittance,  $U$ , is 1.176 Btu/(h·ft<sup>2</sup>·°F). The surface heat loss is

$$\begin{aligned} \phi &= UA (T_i - T_o) \\ &= 1.176 [(9) (18 + 18 + 36 + 36) (100 - 0)] \\ &\quad + 1.176 \{(9) (18 + 18 + 36 + 36) [(100 + 50) / 2 - 0]\} \\ &\quad + 1.176 [(18) (36)] (100 - 0) \\ &= 276,200 \text{ Btu/h} \end{aligned}$$

#### C.12.2.5.2 Forced Draught without Louvers

This case is discussed to show that heat loss is from four to eight times greater without top louvers than when louvers are present. This loss is caused by an unimpeded natural draught of air through the tube bundle. Under such conditions, it is reasonable to assume an air velocity of 50 ft/min at the bundle face. Assume the following air-cooled heat exchanger geometry, as used in the example in C.12.2.3: A totally

enclosed air-cooled heat exchanger is 14 ft wide, 36 ft long, and 8 ft high. Also assume that the air is heated from 0 °F to 100 °F.

The heat loss is calculated as follows: The warm air loss through the bundle is

$$\begin{aligned}q_m &= 3600 v \rho_i A \\ &= (3600) (50/60) (0.0709) [(14) (36)] \\ &= 107,200 \text{ lb/h}\end{aligned}$$

This leads to the following heat loss:

$$\begin{aligned}\phi &= q_m c_p (T_i - T_o) \\ &= (107,200) (0.24) (100 - 0) \\ &= 2,572,000 \text{ Btu/h}\end{aligned}$$

For other designs that can require analysis, it is recommended that the principles shown in these examples be applied.

## Annex D (informative)

### Recommended Procedure for Airflow Measurement of Air-cooled Heat Exchangers

#### D.1 Scope

This annex provides standardized guidelines for the measurement, analysis, and reporting of airflow air-cooled heat exchanger fans at the Vendor's site. Additional information and procedures may be found in ISO 3744.

#### D.2 Equipment Required

All instruments should be calibrated at the instrument manufacturers' recommended intervals.

The instruments should be as specified in Table D.1.

**Table D.1 — Instruments**

Parameter Being Measured	Instrument
Velocity	Digital anemometer with a minimum head diameter of 70 mm (2 ¾ in.); this may be a propeller type or rotating vane type.
Static pressure	Standard type static pressure probe designed to minimize velocity effect.
Temperature	"K" type digital thermometer
Power	Wattmeter

#### D.3 Procedure

##### D.3.1 Ambient Conditions

###### D.3.1.1 Rain

If rain or precipitation is occurring, the test should not be conducted.

###### D.3.1.2 Wind

Wind velocity should be measured at the start and end of the airflow test using a rotating vane anemometer. This measurement should be taken at a location that is upwind and unobstructed. If wind velocity is greater than 16 km/h (10 mph), the test should not be conducted. Record wind speed on an airflow test form data sheet.

###### D.3.1.3 Air Temperature Through the Fan

Ambient air temperature should be taken at a minimum distance of 1 m (3 ft) away from any heat exchangers or equipment that can affect the reading. This should be done before and after the airflow test is completed. Record temperature on an airflow test form data sheet.

When the fan is in service, the air temperature through the fan differs from ambient. This is especially true of induced draught units that have an increased temperature due to the heat exchanger when in use. If an airflow test is conducted while the heat exchanger is in service, the air temperature should be taken in one of two locations depending on the draught type. For a forced draught unit, the temperature measurement should be taken in the plane 150 mm (6 in.) below the fan ring. For an induced draught unit, the temperature should be taken 150 mm (6 in.) above the fan ring.

#### **D.3.1.4 Relative Humidity**

Relative humidity can be obtained from a nearby weather station or with a hygrometer. Record relative humidity on an airflow test data sheet.

#### **D.3.1.5 Atmospheric Pressure**

Barometric pressure can be obtained from a nearby weather station or airport and corrected for the difference in elevation of the barometer from the unit being tested. Record atmospheric pressure on an airflow test data sheet.

#### **D.3.1.6 Elevation**

Elevation from sea level can be obtained from the site map of the location at which the testing is being conducted. Record elevation on an airflow test data sheet.

### **D.3.2 Fan Measurements**

#### **D.3.2.1 Fan Speed**

Fan speed is measured at the fan shaft using a mechanical contact tachometer. Record fan speed on an airflow test data sheet.

#### **D.3.2.2 Tip Clearance**

The fan blade tip clearance should be measured for at least 25 % of the blades. Record tip clearance on an airflow test data sheet.

#### **D.3.2.3 Blade Pitch**

The fan blade pitch angle should be measured for at least 25 % of the blades using a protractor. The pitch should be measured at the location on the blade specified by the fan manufacturer. Record blade pitch on an airflow test data sheet.

### **D.3.3 Static Pressure**

The static pressure drop should be measured with a manometer at the four corners of the fan plenum by means of probes. Figure D.1 shows the location of the test holes for both induced and forced draught units. It is recommended that the holes be drilled in the plenum prior to starting the test. Record the four static pressure readings on an airflow test data sheet.

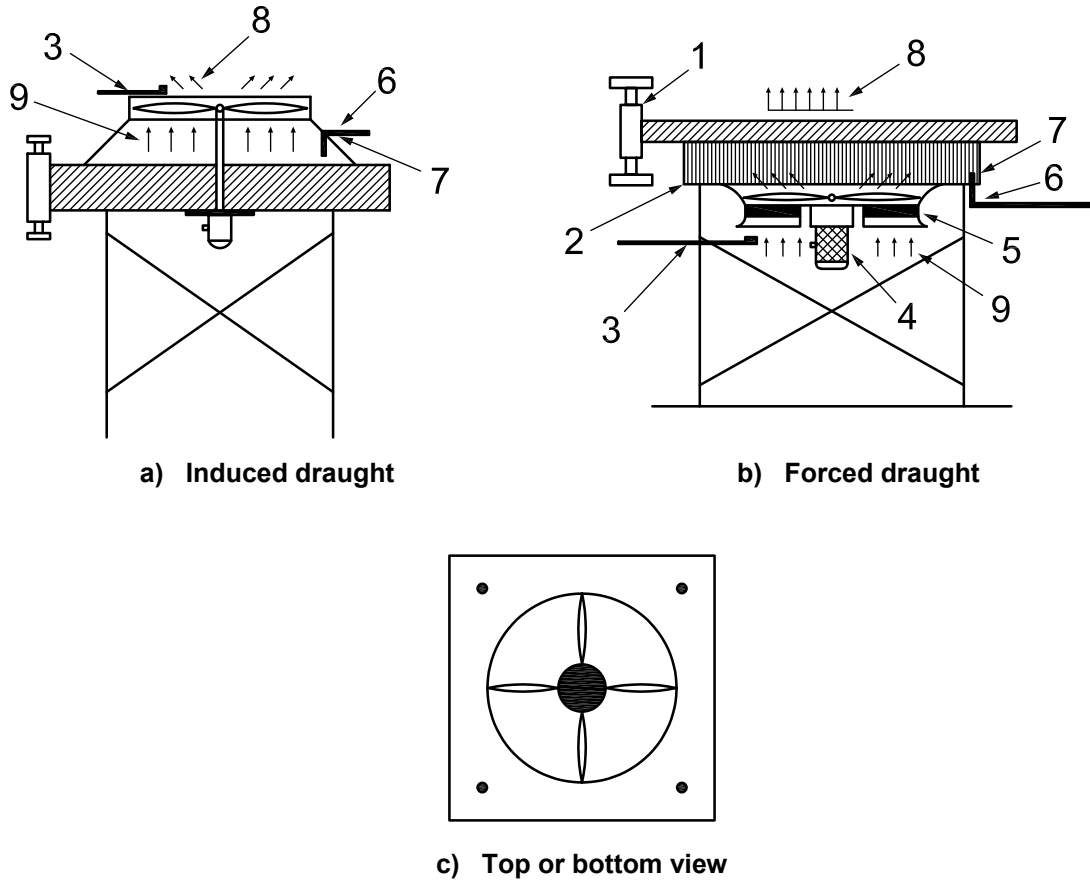
**Key**

1	heater	6	static pressure probe (four corners)
2	plenum	7	drilled hole [8 mm ( $\frac{5}{16}$ in.)], four off
3	anemometer	8	exhaust air with yaw
4	motor	9	inlet air
5	inlet bell		

**Figure D.1 — Static Pressure Probe Locations****D.3.4 Fan Driver Power**

Test measurements are made at the input power using a wattmeter. Record this on an airflow test data sheet.

**D.3.5 Air Velocity****D.3.5.1 Determining Plane of Velocity Measurements**

Air velocity measurements should be taken in a plane parallel to the fan. For a forced draught unit, this plane should be below the fan, as close as possible to the fan ring or inlet bell to negate the effects of ambient wind. For an induced draught unit, this plane should be above the fan and as close to the fan as possible to negate the effects of ambient wind.

The anemometer is held parallel to the plane of the fan during the reading. The velocity reading can be affected by the yaw of the fan. If the angle between the observed direction of air flow and the anemometer axis is more than 5 degrees, it is necessary to make corrections to the velocity readings. See paragraph D.4.2.2.

**D.3.5.2 Determining Location of Velocity Measurements**

It is necessary to measure the air velocity at several locations within this plane, as flow is not uniform throughout the fan diameter. Readings should be taken in four quadrant traverses at 90 degree angles from each other. The location of the traverse may be rotated  $\pm 5$  degrees to avoid beams or other obstructions that may affect airflow measurements. The number of measurements per traverse can be determined using Table D.2. The plane with locations of the measurement points is shown in Figure D.2 for five velocity bands. D.4.2.1 shows the calculation to determine the area of each velocity band and the distance in from the fan ring at which each of the velocity measurements should be taken.

**Table D.2 — Location of Measurement Points**

Fan Diameter <i>D</i> m (ft)	Number of Measurements per Quadrant (also Number of Velocity Bands Created)
$\leq 1.2$ ( $\leq 4$ )	3
$\leq 1.8$ (6) and $> 1.2$ (4)	4
$\leq 4.9$ (16) and $> 1.8$ (6)	5
$\leq 6.1$ (20) and $> 4.9$ (16)	6
$\leq 7.3$ ( $\leq 24$ )	7

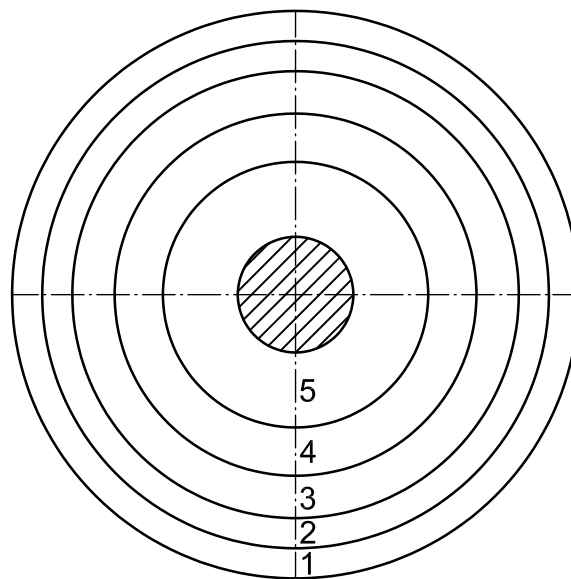

**Figure D.2 — Location of Measurement Points**

### D.3.5.3 Test

Anemometer should be placed at each location for no less than 30 s to determine average velocity reading. Record this on an airflow test data sheet.

## D.4 Calculations

### D.4.1 Symbols

$A_{\text{BAND}}$	Area enclosed in each velocity band
$A_{\text{FR}}$	Area inside the fan ring
$A_{\text{NET}}$	Net free area
$A_{\text{SD}}$	Area of seal disc (or hub plate if there is no seal disc)
$D_{\text{FR}}$	Diameter of the fan ring
$D_{\text{SD}}$	Diameter of the seal disk
$F_{\text{DES}}$	Designed volumetric airflow
$F_{\text{MEAS}}$	Volumetric airflow
$F_{\text{CORR}}$	Volumetric airflow corrected for density
$e$	Air Cooled Heat Exchanger (ACHE) manufacturer's power exponent (typically ranges from 2.7 to 3.2)
$h$	Hydraulic head (determined by ACHE manufacturer, typically ranges from 1.7 to 2.2)
$L_{\text{MP}}$	Distance from fan ring to measuring point
$N_{\text{bands}}$	Number of velocity bands (selected using Table D.2)
$\eta_{\text{ACHE}}$	Efficiency of the fan, including motor and drive losses
$\eta_{\text{DRIVE}}$	Efficiency of the drive
$\eta_{\text{MOTOR}}$	Efficiency of the motor

$\eta_{\text{TOT}}$	Total efficiency of the fan
$\eta_{\text{STATIC}}$	Static efficiency of the fan
$P_{\text{DES}}$	Static pressure, design
$P_{\text{MEAS}}$	Static pressure, measured
$P_{\text{TOT}}$	Total pressure, measured
$\rho_{\text{DESIGN}}$	Design density
$\rho_{\text{MEAS}}$	Density
$R_{\text{BAND}}$	Radius from center of fan to center of velocity ring
$\theta$	Angle of yaw (offset of flow direction from vertical axis of measurement)
$V_{\text{AVG}}$	Average of all velocity measurements taken (12 for 3 velocity bands, 16 for 4 bands, etc.)
$V_{\text{CORR}}$	Velocity corrected for yaw
$V_{\text{MEAS}}$	Velocity
$W_{\text{MEAS}}$	Power
$\pi$	Constant, equal to 3.1415926

## D.4.2 Equations

### D.4.2.1 Determining Location of Air Velocity Measurements

$$A_{\text{FR}} = \pi \times D_{\text{FR}}^2 / 4$$

$$A_{\text{SD}} = \pi \times D_{\text{SD}}^2 / 4$$

$$A_{\text{NET}} = A_{\text{FR}} - A_{\text{SD}}$$

$$A_{\text{BAND}} = A_{\text{NET}} / N_{\text{bands}}$$

$$R_{\text{BAND}1} = \sqrt{[(A_{\text{FR}} - 0.5A_{\text{BAND}}) / \pi]}$$

$$R_{\text{BAND2}} = \sqrt{[(A_{\text{FR}} - 1.5 A_{\text{BAND}}) / \pi]}$$

$$R_{\text{BAND3}} = \sqrt{[(A_{\text{FR}} - 2.5 A_{\text{BAND}}) / \pi]}$$

$$R_{\text{BAND4}} = \sqrt{[(A_{\text{FR}} - 3.5 A_{\text{BAND}}) / \pi]}$$

$$R_{\text{BAND5}} = \sqrt{[(A_{\text{FR}} - 4.5 A_{\text{BAND}}) / \pi]}$$

$$R_{\text{BAND6}} = \sqrt{[(A_{\text{FR}} - 5.5 A_{\text{BAND}}) / \pi]}$$

$$R_{\text{BAND7}} = \sqrt{[(A_{\text{FR}} - 6.5 A_{\text{BAND}}) / \pi]}$$

$$L_{\text{MP}} = 0.5 D - R_{\text{BAND}}$$

#### D.4.2.2 Correcting for Yaw

It is generally recognized that velocity measurements having less than 5 degree yaw produce results within 1 % uncertainty, which should be acceptable for testing within the context of this annex. For desired accuracies greater than 1 %, or for corrections of yaw angles greater than 5°, corrections can be made based on the instrument manufacturer's correction-calibration curve or one specially developed by the testing agency.

#### D.4.2.3 Data Reduction

It is necessary to reduce multiple readings taken over time (wind speed, air temperature), or taken at different locations (static pressure, power, air velocity) to a single set of numbers by arithmetic averaging. If velocity measurements are corrected for yaw, the corrected values should be used to obtain the average.

#### D.4.2.4 Determining Fan Airflow

$$F_{\text{MEAS}} = A_{\text{NET}} \times V_{\text{AVG}}$$

#### D.4.2.5 Absorbed Fan Shaft Power

$$W_{\text{FAN}} = W_{\text{INPUT}} \times \eta_{\text{DRIVE}} \times \eta_{\text{MOTOR}}$$

#### D.4.2.6 Correcting for Design Conditions

Most often, the testing done at the Vendor's facility is not done under the same conditions for which the fan is used in the field. It is likely that the elevation, humidity, and/or temperature will be different. After the test has been done, these calculations can be used to modify the result to take in to account the density change due to these differences.

A correction to measured airflow and horsepower based on differences in air density and fan speed should be ideally made based on the individual fan and ACHE provider calculations where the proper system head matching is made between the fan aerodynamic characteristics and the ACHE hydraulic characteristics. This also includes a correction for differences between design and test pitch.

A method to estimate these corrections can be applied based on the standard fan laws using generalized flow exponents, where a constant blade pitch is assumed, as follows.

Airflow rate correction:

$$F_{\text{CORR}} = F_{\text{MEAS}} \times (P_{\text{DESIGN}}/P_{\text{MEAS}})^{1/n} \times (\rho_{\text{DESIGN}}/\rho_{\text{MEAS}}) \times (V_{\text{RPM,DESIGN}}/V_{\text{RPM,MEAS}})$$

Power correction:

$$W_{\text{CORR}} = W_{\text{FAN}} \times (F_{\text{CORR}}/F_{\text{MEAS}})^e$$

Project corrected test performance to design flow condition:

$$F_{\text{PROJ-DES}} = F_{\text{CORR}}$$

$$W_{\text{PROJ-DES}} = W_{\text{CORR}} \times (F_{\text{DES}}/F_{\text{CORR}})^e$$

#### D.4.2.7 Determining Fan Efficiency

$$\eta_{\text{STATIC}} = (F_{\text{MEAS}} \times P_{\text{STATIC}}) / (6356 \times W_{\text{FAN}})$$

$$\eta_{\text{TOT}} = (F_{\text{MEAS}} \times P_{\text{TOT}}) / (6356 \times W_{\text{FAN}})$$

$$\eta_{\text{ACHE}} = (F_{\text{MEAS}} \times P_{\text{TOT}}) / (6356 \times W_{\text{INPUT}})$$

The conversion factor 6356 is used when  $F$  is in cubic feet per minute,  $P$  is in inches of water, and  $W$  is in horsepower.

## Annex E (informative)

### Measurement of Noise from Air-cooled Heat Exchangers

#### E.1 General

##### E.1.1 Purpose

This annex gives guidance on standard procedures for measuring and reporting sound-pressure levels ( $L_p$ ) and sound-power levels ( $L_W$ ) for air-cooled heat exchangers.

##### E.1.2 Scope

This procedure applies to air-cooled heat exchangers, including both forced- and induced-draft type units. The steps are based on testing complete air-cooled exchangers and are not intended for testing individual components such as fans, motors, gears, etc. Separate procedures are given for the following types of tests:

- a) test of an isolated single-bay air-cooled exchanger for determining sound-power levels and sound-pressure levels in accordance with E.2;
- b) procedures for conducting noise tests on a single bay of installed air-cooled exchangers (normally multi-bay installations) in accordance with E.3.

##### E.1.3 Instrumentation

The required instrumentation and applicable specifications that are used to perform the measurements required are shown in Table E.1.

**Table E.1 — Required Instrumentation and Applicable Specifications**

Instrument	Specification
Sound level meter, including microphone, type I precision	ANSI S1.4-1983 (R2006)
Octave band filter, type E, class II	—
Acoustic calibrator of coupler type	ANSI S1.4-1983 (R2006)
Wind screen	ANSI S1.4-1983 (R2006)

##### E.1.4 Nomenclature

The symbols and abbreviations are used in this annex are given in Table E.2.

**Table E.2 — Symbols and Abbreviations**

Abbreviation or Symbol	Definition
$B$	Measuring distance from surface
$D$	Fan diameter
dB	Unit of measure for sound level
dB(A)	Decibel weighted to correspond to standard "A" scale
$H$	Height of geometric center
hp	Horsepower
Hz	Hertz, sound frequency
$l$	Length of bay
$L_p$	Sound-pressure level
$\overline{L_p}$	Mean sound-pressure level
$\overline{L_{p,cyl}}$	Mean sound-pressure level for cylinder
$\overline{L_{p,hemi}}$	Mean sound-pressure level for hemisphere
$L_W$	Sound-power level
$L_{W,bay}$	Sound-power level for test bay
$L_{W,design}$	Sound-power level at design power
$L_{W,fan}$	Sound-power level per fan
$L_{W,hemi}$	Sound-power level for hemisphere
$L_{W,test}$	Sound-power level at test motor horsepower
$N$	Number of fans per bay
$n$	Number of measurement positions per source
$P_{test}$	Test power
$P_{design}$	Design power
$R$	Radius of hemisphere and cylinder
$S$	Surface area (measurement surface)
$S_o$	Reference area of 1 m <sup>2</sup>
$W$	Width of one bay

## E.2 Procedure for Conducting Noise Tests on an Isolated Single Bay

### E.2.1 Procedure for Obtaining Noise Test Data

#### E.2.1.1 Description of Test Set-up

The more accurate noise tests on air-cooled heat exchangers are those that are performed on a single bay without interference from nearby noise or structures. Such accuracy is usually precluded on an operating installation but is attainable at the point of assembly. Units that have typical overall dimensions of from 4 m (13.1 ft) to 6 m (19.7 ft) wide, 7 m (23 ft) to 12 m (39.4 ft) long, 2 m (6.6 ft) to 5 m (16.4 ft) high are discussed here.

For testing, the unit should be supported above grade high enough for reasonable air access during the test. An elevation of 3 m (9.8 ft) to 6 m (19.7 ft) from grade to air inlet is usually adequate to minimize ground effects. There are several optional pieces of equipment that influence noise to a negligible degree and such pieces may be omitted from the assembly for noise test purposes. Included in this category are louvers, walkways, and recirculation chambers. (The presence or absence of recirculation walls has little effect on the total noise emitted, but can cause noise to be emitted in a different direction or at a different location.)

In many cases, tests are conducted on completed units immediately prior to shipment. However, if noise levels are critical and a large number of units is involved, consideration should be given to testing a single unit early enough to permit design changes.

#### E.2.1.2 Test Conditions

The equipment should be operating as near as is practical to design fan tip speed and motor horsepower. Since it is necessary to run most tests at conditions other than design conditions, it is desirable to agree beforehand on the corrections to make for these variables. If the customer requires, the blade angle can be set to duplicate design horsepower when temperature or elevation differs appreciably from design. Refer to E.2.2.1.1 if it is necessary to make corrections for background noise that differs from design conditions.

#### E.2.1.3 Location of Test Measuring Points

A radius of 10 m (32.8 ft) used to define imaginary hemispherical and cylindrical surfaces surrounding the equipment being tested is recommended. The test measuring points should be located on this surface. There should be nine points on the hemisphere and four points on the cylinder. (See Figure E.1 and Table E.3 for the location of these test points.)

The geometric center is located at the center of the unit on a plane midway between the air inlet and air outlet for both forced- and induced-draft units. A radius of 10 m (32.8 ft) is recommended; however the radius can range from 9 m (29.5 ft) to 12 m (39.4 ft) with little effect on results. The test points should be far enough from the equipment to minimize near field distortions, yet near enough to allow positioning the microphone at the various points on the imaginary enclosed surface. All fans should be running during testing.

In addition to the above readings, which are used to calculate  $L_W$ , a set of readings at a single point should be taken below each fan. On forced-draft units, the measurement point should be on a horizontal plane 1 m (3.3 ft) below the lower edge of the fan ring. The maximum reading attainable on this plane should be taken by placing the microphone no closer than 1 m (3.3 ft) from the motor, machinery mount, or other members. On induced-draft units, this measurement point should be on a horizontal plane 1 m (3.3 ft) below the finned tubes. The maximum reading attainable on this plane should be taken while placing the microphone no closer than 1 m (3.3 ft) from the motor, machinery mount, or other members. [The noise meter should be reading dB(A) while finding the maximum noise point.] All fans should be running during these readings. These data are taken for future reference in correlating  $L_W$  and sound level data and for estimating noise levels directly below the unit.

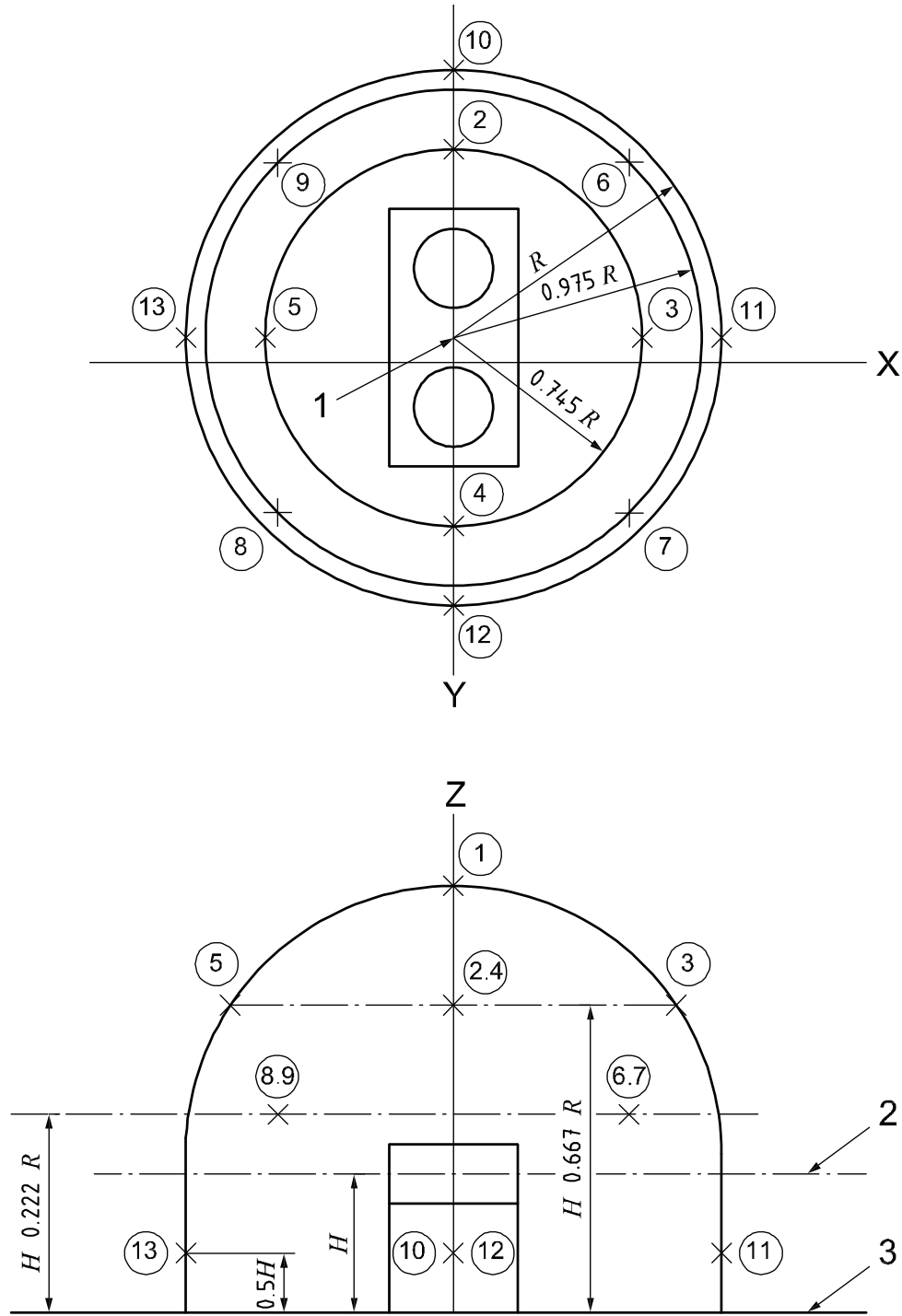

**Key**

- 1 geometric center
- 2 geometric center plane
- 3 grade
- x test point location

**Figure E.1 — Isolated Single Bay Noise Measurement Points**

**Table E.3 — Isolated Single Bay Noise Measurement Points**

Position	X	Y	Z
1	0.0	0.0	+1.000R
2	0.0	+0.745 R	+0.667R
3	+0.745R	0.0	+0.667R
4	0.0	-0.745R	+0.667R
5	-0.745R	0.0	+0.667R
6	+0.689R	+0.689R	+0.222R
7	+0.689R	-0.689R	+0.222R
8	-0.689R	-0.689R	+0.222R
9	-0.689R	+0.689R	+0.222R
10	0.0	+1.000R	-0.500H
11	+1.000R	0.0	-0.500H
12	0.0	-1.000R	-0.500H
13	-1.000R	0.0	-0.500H

*R* indicates the radius; *H* indicates the geometric center plane.

**E.2.1.4 Checklist**

A noise test is usually run immediately before a unit is shipped. Therefore, it is necessary to perform all required steps and record all pertinent data, since it is impractical to recall the equipment and rerun the test at a later date. The following steps should aid operators in preparing for a test.

- a) Prepare all drawings and data forms prior to the test. Lay out the test points in the x, y plane and paint spots on the working surface. Then, it is necessary to measure only the z dimension during the test.
- b) Check that all noise test equipment is in working order and calibrated. A discharged battery, a faulty connection or similar problem has invalidated many tests.
- c) Check that equipment necessary to position the microphone at all test points is on hand prior to beginning the test.
- d) Check the weather forecast. The test should not be run during rain or while winds are above 3 m/s (7 mph).
- e) Do a preliminary check of motor amperage draw and voltage to ensure the operation of motors near design speed.
- f) Start the unit and check for any unusual noises or problems. Is either fan running backwards? Is there any unusual belt, gear, motor, or bearing noise? Are there any loose parts rattling?

Be aware that toothed sheaves with lobed or toothed belts create a dominant noise in the 1000 Hz to 2000 Hz range.

**E.2.1.5 Recording of Data**

Prior to recording the data, a preliminary survey should be conducted with the sound level meter on the dB(A) setting. If the noise levels for either the hemisphere or cylinder differ by more than 6 dB(A), either additional measurement positions should be used or the hemisphere and cylinder radius should be increased. If the large difference results from background noise, it may be necessary to record background noise at each measuring point. If it is not possible to measure the noise emission at a particular point because of high background noise, either the source of the background noise should be reduced or eliminated or the measurement from a similar point may be used. The latter procedure is not recommended; when it is used, the details and the point should be noted in the test report.

Record all data as required on the data sheet (see E.2.3.2 and E.2.3.3). The calibration readings should be recorded at the start and finish of a noise test. Background readings should be taken at every fifth test point (more often if either party feels conditions warrant it). All sound level readings should be taken with the meter set to the “slow” response and with a wind screen over the microphone.

**E.2.2 Calculations and Interpretation**

**E.2.2.1 Reducing Test Data**

**E.2.2.1.1 Correction for Background Noise**

If the test point reading exceeds the background level by more than 10 dB, no correction of the test point reading is required. When the difference between the noise level and the background is less than 3 dB, the measurements have no significance and valid test results cannot be obtained. If the difference between the test point reading and the background level is greater than 3 dB, but less than or equal to 10 dB, the measured noise level should be corrected according to Table E.4. This data reduction process is repeated for the overall average value and each octave band reading for all thirteen measurement points on both the hemisphere and cylinder.

**Table E.4 — Background Correction Values**

<b>Difference</b> (reading minus background)	<3	3	4	5	6	7	8	9	10	>10
<b>Correction, dB</b>	n.a.	-3.0	-2.2	-1.7	-1.3	-1.0	-0.7	-0.6	-0.5	0.0

This data reduction for one measurement point “X” can be demonstrated by an example as follows:

**Table E.5 — Background Correction Values — Example for One Measurement Point “X”**

<b>Octave band center frequency, Hz</b>	Ave(A)	31.5	63	125	250	500	1000	2000	4000	8000
<b>Background measurement</b>	68.0	63.6	64.8	53.4	53.7	69.1	62.0	52.3	52.8	52.5
<b>Test measurements at point X</b>	80.5	89.1	86.8	81.1	76.4	76.2	71.9	69.2	75.4	71.3

### E.2.2.1.2 Determining Mean Sound-pressure Levels

Correct the test point readings at each location for background noise as shown above. Then determine the mean sound-pressure level for both the hemisphere and the cylinder. The mean sound-pressure level values are determined using the following calculations for two different categories.

- a) If the maximum difference between the “ $n$ ” values being averaged is greater than 6 dB,  $L_p$  is derived from the following logarithmic averaging:

$$\overline{L_p} = 10 \times \log \left\{ \left( \frac{1}{n} \right) \times \sum \left[ \log^{-1} \left( \frac{L_{p,n}}{10} \right) \right] \right\}$$

- b) If the maximum difference between the “ $n$ ” values being averaged is 6 dB or less,  $L_p$  can be optionally derived from the following, simplified arithmetic averaging:

$$\overline{L_p} = \sum \left( \frac{L_{p,n}}{n} \right)$$

This should be done for both the hemisphere and the cylinder such that the following mean sound-pressure levels are determined:

- c)  $\overline{L_{p,\text{hemi}}}$ , where  $n = 9$  test points

$$\overline{L_{p,\text{cyl}}}, \text{ where } n = 4 \text{ test points}$$

### E.2.2.1.3 Calculate Sound-power Level

Convert the representative  $\overline{L_p}$  to  $L_W$ . This is done separately for the hemisphere and for the cylinder using the following expression.

$$L_W = \overline{L_p} + \left[ 10 \times \log \left( \frac{S}{S_0} \right) \right]$$

where

$S$  is the surface area of the hemisphere or cylinder, in square meters;

$S_0$  is the reference area of 1.0 m<sup>2</sup>;

$A_{\text{hemi}}$  is the area of the hemisphere in square meters, equal to 6.28 x  $R^2$ ;

$A_{\text{cyl}}$  is the area of the cylinder in square meters, equal to 6.28 x  $R \times H$ ;

The following individual  $L_W$  levels are then determined:

$$L_{W,\text{hemi}} \quad \text{for } S = A_{\text{hemi}}$$

$$L_{W,\text{hemi}} \quad \text{for } S = A_{\text{cyl}}$$

The total  $L_W$  for the test bay is then arrived at by logarithmic addition:

$$L_{W,\text{bay}} = 10 \times \log \{[\log^{-1}(L_{W,\text{hemi}}/10) + \log^{-1}(L_{W,\text{cyl}}/10)]\}$$

The sound-power level per test fan can then be backed out for reference purposes as follows:

$$L_{W,\text{fan}} = L_{W,\text{bay}} - 10 \times \log(n)$$

where

$n$  is the number of fans per bay operating during the test.

#### E.2.2.1.4 Design Versus Test Horsepower

Since a test is seldom run with the motor at design horsepower, it is necessary to adjust test conditions to design conditions.

If a watt meter or plant power factor data are not available, the following approximation for test horsepower can be used:

To convert sound-power level calculated at test motor horsepower ( $L_{W,\text{test}}$  at  $P_{\text{test}}$ ) to predicted sound-power level at design power ( $L_{W,\text{design}}$  at  $P_{\text{design}}$ ) use the following equation:

$$L_{W,\text{design}} = L_{W,\text{test}} + 10 \times (\log P_{\text{design}} - \log P_{\text{test}})$$

Test horsepower should be within 15 % of design horsepower to use this equation.

#### E.2.2.2 Application of Reduction Procedures

##### E.2.2.2.1 Background Noise

Adjust test point readings for background noise level. Prepare a tabulation of adjusted values for each position. The example in Table E.4 illustrates the procedure.

##### E.2.2.2.2 Sound-pressure Level

Consider a test in which an imaginary cylinder has the following dimensions:  $R$  equals 10 m and  $H$  equals 4.88 m with adjusted test point readings of 81.9 dB, 74.8 dB, 80.8 dB, and 75.4 dB in one octave band and adjusted test point readings of 51.8 dB, 53.8 dB, 52.9 dB, and 52.3 dB in another octave band.

In the first case, the maximum difference in values being averaged is 7.1 (81.9 – 74.8); therefore, the representative  $L_p$  equals 79.3.

In the second case, the maximum difference in values to be averaged is 2.0 (53.8 – 51.8); therefore, the representative  $L_p$  equals 52.7.

##### E.2.2.2.3 Sound-power Level

Convert representative  $L_p$  for the cylinder in the first case to  $L_W$ . From E.2.2.2.2,  $L_p$  equals 79.3 dB.

$$\begin{aligned} L_W &= L_p + 10 \log(2\pi RH) \\ &= 79.3 + 10 \log(2 \times \pi \times 10 \times 4.88) \\ &= 79.3 + 10 \log 306.6 \\ &= 79.3 + 24.9 \\ &= 104.2 \text{ dB} \end{aligned}$$

Determine the sound-power level per bay, assuming that the hemispherical sound-pressure level equals 106 and the cylindrical sound-pressure level equals 104.2.

$$\begin{aligned} L_{W,\text{bay}} &= 10 \log (6.6114 \times 10^{10}) \\ &= 10 \times 10.82 \\ &= 108.2 \text{ dB} \end{aligned}$$

Determine the sound-power level per fan in a two-fan bay if the sound-pressure level per bay is 108.2.

$$\begin{aligned} L_W &= 108.2 - 10 \log 2 \\ &= 108.2 - 3 \\ &= 105.2 \text{ dB} \end{aligned}$$

#### E.2.2.2.4 Design Versus Test Horsepower

If nameplate horsepower is 25 (18.4 kW), nameplate voltage is 460, nameplate amperage is 31, test voltage is 470, and test amperage is 27, then test horsepower is 22.3 (16.4 kW).

If design horsepower is 23.7 (17.4 kW), test horsepower is 22.3 (16.4 kW), and test sound-power level per fan is 105.2 dB, determine adjusted sound-power level per fan at design horsepower.

$$\begin{aligned} L_{W,\text{design}} &= 105.2 + 10 (\log 23.7 - \log 22.3) \\ &= 105.2 + 10 (1.3747 - 1.3488) \\ &= 105.2 + (10 \times 0.0264) \\ &= 105.5 \text{ dB} \end{aligned}$$

### E.2.3 Reporting of Data

#### E.2.3.1 General Requirements

The noise test report should include a summary sheet with the main results, a description of the equipment tested, and the noise test data.

#### E.2.3.2 Summary

The summary should make reference to this standard.

The principal results of the test should be reported on one sheet. These results should be supported by the test data, calculations and sketches. All calculations and interpretation of data should be in accordance with E.2.2. The calculations should be appended to the noise test report.

The test results should include the following.

- a) The overall sound-power levels and the octave band sound-power levels should be tabulated.
- b) Measurements taken at special locations for future reference in correlating sound-power level and sound level data and for estimating noise levels below the unit should be shown separately.
- c) Corrected and uncorrected noise levels should be reported.

### **E.2.3.3 Requirements for Data Sheets**

Data sheets should include the following.

- a) A sketch of the test layout and microphone locations should be provided. Special measuring locations should be noted on the sketch.
- b) A description of the equipment tested and its operating conditions should be provided.
- c) Details of the measuring equipment including make, model, and serial number should be recorded.
- d) A tabulation of all test data [dB(A) and octave band sound-pressure levels] should be provided, which includes:
  - sound level measurements at each test point;
  - background sound level measurements at selected points;
  - sound level measurements at special locations.

## **E.3 Procedure for Conducting Noise Tests on Installed Units**

### **E.3.1 Procedure for Obtaining Noise Test Data**

#### **E.3.1.1 Description and Requirements of Test**

E.3 covers procedures for noise testing on installed units. However, it should be noted that a more accurate test for the determination of noise levels of air-cooled heat exchangers is given in E.2. The procedure in E.2 is usually not satisfactory for testing installed air-cooled heat exchangers in operating plants.

The procedure outlined in E.2 is ideally suited for shop test situations and employs measurements of sound-pressure levels of an imaginary hemisphere and cylinder having a radius of about 10 m (32.8 ft). This large measuring distance, 10 m (32.8 ft), is impractical for installed heat exchanger testing and yields inaccurate results because of noise interference from other operating plant equipment and the measurement location interference of nearby equipment. In order for a noise test procedure for use on installed multi-bay operating units to yield reasonably accurate results, the noise reading locations should:

- a) be within easy reach using the sound level meter, microphone (with wind screen), microphone cable, and short extension pole;
- b) be 1 m (3.3 ft) from the fan and tube bundle to minimize interference from other plant noises; the 1 m (3.3 ft) measuring distance of sound-pressure level reading has been widely used to determine sound-power levels;
- c) provide representative average sound-pressure levels for the imaginary projected surface of the fan and tube bundle, at a 1 m (3.3 ft) distance, so that the sound-power level of the individual exchanger and the entire exchanger bank can be determined by calculation;
- d) be far enough away from the adjacent exchanger bays so that the background noise level is a minimum of 3 dB (preferably 6 dB) below the level of the test bay. It is normally necessary to shut down the adjacent bays to reduce sufficiently the ambient noise level of the test bay in order to yield more accurate results.

The following noise test procedure for installed operating equipment to determine sound-power levels should yield an accuracy of plus or minus 3 dB compared to the more accurate shop test procedure in E.2. The degree of accuracy is heavily influenced by the background noise level at the time of the test. Every effort should be made to reduce background noise levels to a minimum by making the test before plant start-up or by shutting down adjacent exchangers during the test.

The test accuracy can be detrimentally affected when the air-cooled heat exchanger is located very close to grade or directly adjacent to buildings. These situations increase the sound-pressure levels because sound reflection causes erroneous readings.

### **E.3.1.2 Test Conditions**

The equipment should be operating as near as is practical to design fan tip speed and motor horsepower. Since it is necessary to run most tests at conditions other than design conditions, it is desirable to agree beforehand on the corrections to make for these variables. For example, the blade angle can be set to duplicate design horsepower. (Refer to E.3.2.2.1 if it is necessary to make corrections because test background noise differs from design conditions.)

### **E.3.1.3 Location of Test Measuring Points**

Figure E.2 and Figure E.3 show the recommended measuring locations for induced- and forced-draft units, respectively.

To avoid excessive noise from the fan drive, the microphone should be placed no closer than 1 m from the motor, machinery mounts, or other members.

### **E.3.1.4 Checklist**

A noise test on operating equipment should usually be run over a short period of time, particularly if adjacent operating bays are shut down to reduce background noise for improved test accuracy. Therefore, the recording of all pertinent data should be accomplished as quickly as possible.

The following steps should aid operators in preparing for tests.

- a) Prepare all drawings and data forms prior to the test.
- b) Check that all noise test equipment is in working order and calibrated. A discharged battery, a faulty connection, or similar problem has invalidated many tests.
- c) Check that equipment necessary to position the microphone at all test points is on hand prior to beginning the test.
- d) Check the weather forecast. The test should not be run during rain or while winds are above 3 m/s (7 mph).
- e) Do a preliminary check of motor amperage draw and voltage to ensure the operation of motors near design speed.
- f) Check the unit for any unusual noises or problems. Is there any unusual belt, gear, motor, or bearing noise? Are there any loose parts rattling?

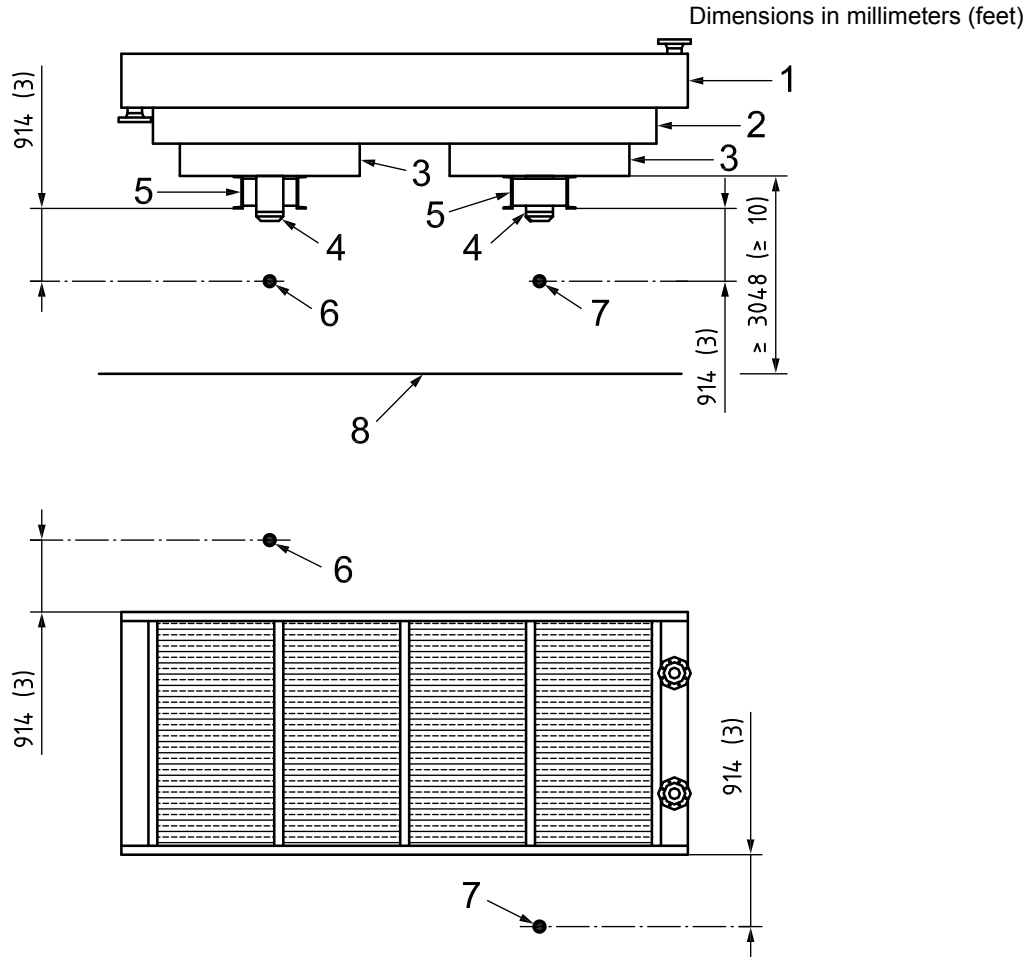

**Key**

- |   |                   |   |                         |
|---|-------------------|---|-------------------------|
| 1 | plenum side frame | 5 | machinery mount         |
| 2 | plenum            | 6 | measurement location #1 |
| 3 | fan ring          | 7 | measurement location #2 |
| 4 | motor             | 8 | ground level            |

**Figure E.2 —  $L_p$  Measurement Locations — Forced Draught Unit (2-fan Bay)**

- g) Check that there are no intermittent noise sources or steam leaks adjacent to the test location that can cause inaccurate test readings.
- h) Be aware that toothed sheaves with lobed or toothed belts create a dominant noise in the 1000 Hz to 2000 Hz range.

**E.3.1.5 Recording of Data**

Prior to recording the data, a preliminary survey should be conducted with the sound level meter on the dB(A) setting. If the noise levels differ by more than 6 dB(A) across any radiating surface, additional measurements should be taken. A subjective impression by ear should be made to decide whether the noise is from the source under test or another source. If it is not possible to obtain valid noise data from a particular surface because of background noise, it will be necessary to reduce or eliminate the source of the background noise. The only other option is to conduct the test on another bay of identical design and construction.



3 dB, the measurements have no significance and valid test results cannot be obtained. If the difference between the test point reading and the background level is greater than 3 dB, but less than or equal to 10 dB in any octave band center frequency, the measured noise level should be corrected according to Table E.6.

This procedure is explained by way of the following example:

**Table E.6 — Background Noise Correction Values**

<b>Difference</b> (reading minus background)	<3	3	4	5	6	7	8	9	10	>10
<b>Correction, dB</b>	n.a.	-3.0	-2.2	-1.7	-1.3	-1.0	-0.7	-0.6	-0.5	0.0

This data reduction for one measurement point “X” can be demonstrated by the example shown in Table E.7.

**Table E.7 — Background Noise Correction Values — Example Using One Measurement Point “X”**

<b>Octave band center frequency, Hz</b>	Ave(A)	31.5	63	125	250	500	1000	2000	4000	8000
<b>Background measurement</b>	68.0	63.6	64.8	53.4	53.7	69.1	62.0	52.3	52.8	52.5
<b>Test measurements at point X</b>	80.5	89.1	86.8	81.1	76.4	76.2	71.9	69.2	75.4	71.3

**Table E.8 — Background Noise Correction Values — Example Using Measurement Point “n”**

<b>Octave band center frequency, Hz</b>	Ave(A)	31.5	63	125	250	500	1000	2000	4000	8000
<b>Background measurement</b>	68.0	63.6	64.8	53.4	53.7	69.1	62.0	52.3	52.8	52.5
<b><math>L_p</math> Measurements at point “n”</b>	80.5	89.1	86.8	81.1	76.4	76.2	71.9	69.2	75.4	71.3
<b>Measurement minus background</b>	12.5	25.5	22.0	27.7	22.7	7.1	9.9	16.9	22.6	18.8
<b>Correction for background</b>	0.0	0.0	0.0	0.0	0.0	-1.0	-0.6	0.0	0.0	0.0
<b>Background-corrected <math>L_p</math></b>	80.5	89.1	86.8	81.1	76.4	75.2	71.3	69.2	75.4	71.3

**E.3.2.1.2 Determining Mean Sound-pressure Levels**

Correct test point readings at each location for background noise. Determine  $L_p$  for both fans and bundles for the overall dB(A), plus each of the nine frequencies.

The mean sound-pressure level values are determined using the following equations.

If the maximum difference between values being averaged is greater than 6 dB,  $L_p$  is derived from the following equation:

$$\overline{L}_p = 10 \times \log \left\{ (1/n) \times \sum [\log^{-1}(L_{p,n}/10)] \right\}$$

If the maximum difference between values being averaged is 6 dB or less,  $L_p$  is derived from the following equation:

$$\overline{L}_p = \sum [L_{p,n}] / n$$

### E.3.2.1.3 Sound-power Level

Convert the mean sound-pressure levels to sound-power levels. This is done for each of the nine frequencies plus the overall dB(A) and is done separately for each fan and bundle. To convert  $L_p$  to  $L_W$ , use the following equation:

$$L_W = L_p + 10 \log (S/S_0)$$

where

$S$  is the projected surface area as defined in Figure E.2 and Figure E.3, expressed in square meters;

$S_0$  is a reference area of 1 m<sup>2</sup>.

Be aware that the 20 degree divergence angle is an empirical means of causing the near field test results to match closely with the far field test results.

$$\begin{aligned} A_{\text{fans}} &= N (\pi/4) [D + (2 \times \tan 20^\circ \times B)]^2 \\ &= N (3.1416/4) [D + (1.73 \times B)]^2 \end{aligned}$$

Sound-power level per bay equals the sum of  $L_W$  for fans plus bundles.

To add  $L_W$ , sound-power level per fan can be determined as follows:

$$L_{W:\text{fan}} = L_{W:\text{bay}} - 10 \log N$$

### E.3.2.1.4 Design Versus Test Horsepower

Since a test is seldom run with the motor at design horsepower, it is necessary to adjust test conditions to design conditions. In most cases, the following approximation for test horsepower can be used:

To convert sound-power level calculated at test motor horsepower ( $L_{p,\text{test}}$  at  $P_{\text{test}}$ ) to predicted sound-power level at design power ( $L_{W,\text{design}}$  at  $P_{\text{test}}$ ) use the following equation:

$$L_{W,\text{design}} = L_{W,\text{test}} + 10 (\log P_{\text{design}} - \log P_{\text{test}})$$

Test horsepower should be within 15 % of design horsepower to use this equation.

### E.3.2.2 Application of Reduction Procedures

#### E.3.2.2.1 Background Noise

Adjust test point readings for background noise level. Prepare a tabulation of adjusted  $L_p$  values for each test position. The example in Table E.9 illustrates the procedure.

**Table E.9 — Background Noise Correction Values**

<b>Difference</b> (reading minus background)	<3	3	4	5	6	7	8	9	10	>10
<b>Correction, dB</b>	n.a.	-3.0	-2.2	-1.7	-1.3	-1.0	-0.7	-0.6	-0.5	0.0

This data reduction for one measurement point “X” can be demonstrated by the example shown in Table E.10.

**Table E.10 — Background Noise Correction Values — Example Using One Measurement Point “X”**

<b>Octave band center frequency, Hz</b>	Ave(A)	31.5	63	125	250	500	1000	2000	4000	8000
<b>Background measurement</b>	68.0	63.6	64.8	53.4	53.7	69.1	62.0	52.3	52.8	52.5
<b>Test measurements at point X</b>	80.5	89.1	86.8	81.1	76.4	76.2	71.9	69.2	75.4	71.3

**Table E.11 — Background Noise Correction Values — Example Using Measurement Point “n”**

<b>Octave band center frequency, Hz</b>	Ave(A)	31.5	63	125	250	500	1000	2000	4000	8000
<b>Background measurement</b>	68.0	63.6	64.8	53.4	53.7	69.1	62.0	52.3	52.8	52.5
<b><math>L_p</math> Measurements at point “n”</b>	80.5	89.1	86.8	81.1	76.4	76.2	71.9	69.2	75.4	71.3
<b>Measurement minus background</b>	12.5	25.5	22.0	27.7	22.7	7.1	9.9	16.9	22.6	18.8
<b>Correction for background</b>	0.0	0.0	0.0	0.0	0.0	-1.0	-0.6	0.0	0.0	0.0
<b>Background-corrected <math>L_p</math></b>	80.5	89.1	86.8	81.1	76.4	75.2	71.3	69.2	75.4	71.3

#### E.3.2.2.2 Sound-pressure Level

Consider a test in which the fans have adjusted and overall test point readings of 86.6 dBA, 87.7 dBA, 86.6 dBA, and 85.5 dBA at one point and 88.6 dBA, 82.7 dBA, 90.8 dBA, and 88.6 dBA at another point.

In the first case, the maximum difference in values to be averaged is 2.2 (87.7 – 85.5); therefore, it is not necessary to apply a correction for background noise.

In the second case, the maximum difference in values being averaged is 8.1 (90.8 – 82.7); therefore, it is necessary to correct for background noise.

### E.3.2.2.3 Sound-power Level

Convert  $L_p$  for the fans in the first case to  $L_W$ . From E.3.2.2.2,  $L_p$  equals 86.6 dB. Assume two fans 3.66 m in diameter.

If  $L_p$  for the bundle in the first case is 84.7,  $l$  equals 9.15 m, and  $W$  equals 4.88 m, bundle  $L_W$  is

$$\begin{aligned} L_W &= 84.7 + 10 \log (9.15 \times 4.88) \\ &= 101.2 \text{ dB} \end{aligned}$$

Determine the sound-power level per bay.

In the first case, the sound-power level per fan is determined as follows:

$$\begin{aligned} L_{W:\text{fan}} &= 104.3 - 10 \log 2 \\ &= 101.3 \text{ dB} \end{aligned}$$

### E.3.2.2.4 Design Versus Test Horsepower

If nameplate horsepower is 25, nameplate voltage is 460, nameplate amperage is 31, test voltage is 470, and test amperage is 27.

If design horsepower is 23.7, test horsepower is 22.3, and test  $L_W$  per fan is 102.4, determine adjusted  $L_W$  per fan at design horsepower:

$$\begin{aligned} L_{W:\text{design}} &= 102.4 + 10 (\log 23.7 - \log 22.3) \\ &= 102.4 + 0.3 \\ &= 102.7 \text{ dB} \end{aligned}$$

## E.3.3 Reporting of Data

### E.3.3.1 General Requirements

The noise test report should include a summary sheet with the main results, a description of the equipment tested, and the noise test data.

### E.3.3.2 Summary

The summary should make reference to this standard.

The principal results of the test are reported on one sheet. These results are supported by the test data, calculations, and sketches which follow. All calculations and interpretation of data should be in accordance with E.3.2. The calculations should be appended to the noise test report. The test results should include tabulated overall sound-power levels and the octave band sound-power levels.

Measurements taken at special locations, such as for hearing conservation purposes or for future reference, should be shown separately. Corrected and uncorrected noise levels should be reported.

### **E.3.3.3 Requirements for Data Sheets**

Data sheets should include the following:

- a) sketch of the test layout and microphone locations should be provided; special measuring locations should be noted on the sketch;
- b) description of the equipment tested and its operating conditions should be provided;
- c) details of the measuring equipment including make, model, and serial number;
- d) A tabulation of all test data [dB(A) and octave band sound-pressure levels], which should include:
  - sound level measurements at each test point;
  - background sound level measurements at selected points;
  - sound level measurements at special locations.

## Bibliography

- [1] AISC M011, *Manual of steel construction — Specification for the design, fabrication and erection of structural steel for buildings*
- [2] AISC S302, *Code of standard practice for steel buildings and bridges*<sup>10</sup>
- [3] ASME II, *ASME Boiler and Pressure Vessel Code (ASME BPVC)*, Section II, Materials
- [4] ASME VIII, *ASME Boiler and Pressure Vessel Code (ASME BPVC)*, Section VIII, Rules for construction of pressure vessels, Division 1
- [5] ASME B1.20.1, *Pipe Threads, General Purpose (Inch)*
- [6] ASME B16.11, *Forged Fittings, Socket-Welding and Threaded*
- [7] ASME B36.10M, *Welded and Seamless Wrought Steel Pipe*
- [8] ASTM D97, *Standard Test Method for Pour Point of Petroleum Products*
- [9] REID, E.B. and ALLEN, H.I., Estimating Pour Points of Petroleum Distillate Blends, *Petroleum Refiner*, 30, No. 5, pp. 93-95, 1951
- [10] Index Predicts Cloud, Pour, and Flash Points of Distillate Fuel Blends, *Oil and Gas Journal*, November 9, 68, No. 45, pp. 66-69, 1970
- [11] NELSON, W.L., Is There a Practical Pour-Point Correlation?, *Oil and Gas Journal*, May 14, 71, No. 20, p. 108, 1973
- [12] Phase Equilibria in Systems Containing Water, Chapter 9, *Technical Data Book—Petroleum Refining*, 4th ed., American Petroleum Institute, Washington, D.C., pp. 9-23-9-43, 1983
- [13] MCADAMS, W.H., *Heat Transmission*, 3rd ed., McGraw-Hill, New York, pp. 268-271, 1954
- [14] KERN, D.Q., *Process Heat Transfer*, McGraw-Hill, New York, 1950, pp. 538-541
- [15] GARDNER, K.A., Efficiency of Extended Surface, *Trans. ASME, Series C: J. Heat Transfer*, 67, No. 8, pp. 621-628, 1945
- [16] GRIMISON, E.D., Correlation and Utilization of New Data on Flow Resistance and Heat Transfer for Cross Flow of Gases over Tube Banks, *Trans. ASME, Series C: J. Heat Transfer*, 59, No. 7, pp. 538-594, 1937
- [17] NACE MR0175, *Petroleum and Natural Gas Industries — Materials for Use in H<sub>2</sub>S-containing Environments in Oil and Gas Production — Parts 1, 2 and 3*
- [18] EN 10160, *Ultrasonic testing of steel flat product of thickness equal or greater than 6 mm (reflection method)*

---

<sup>10</sup> American Institute of Steel Construction, One East Wacker Drive, Suite 700, Chicago, IL 60601-1802, USA

- 
- [19] ASTM A578, *Standard Specification for Straight-Beam Ultrasonic Examination of Rolled Steel Plates for Special Applications*
  - [20] API RP 571-11, *Damage mechanisms affecting fixed equipment in the refining industry*
  - [21] ANSI S1.4, *American National Standard Specification for Sound Level Meters*
  - [22] ISO 3744, *Acoustics — Determination of sound power levels and sound energy levels of noise sources using sound pressure — Engineering methods for an essentially free field over a reflecting plane*



# EXPLORE SOME MORE

Check out more of API's certification and training programs, standards, statistics and publications.

## API Monogram™ Licensing Program

Sales: 877-562-5187  
(Toll-free U.S. and Canada)  
(+1) 202-682-8041  
(Local and International)  
Email: [certification@api.org](mailto:certification@api.org)  
Web: [www.api.org/monogram](http://www.api.org/monogram)

## API Quality Registrar (APIQR™)

- ISO 9001
- ISO/TS 29001
- ISO 14001
- OHSAS 18001
- API Spec Q1®
- API Spec Q2™
- API Quality *Plus*™
- Dual Registration

Sales: 877-562-5187  
(Toll-free U.S. and Canada)  
(+1) 202-682-8041  
(Local and International)  
Email: [certification@api.org](mailto:certification@api.org)  
Web: [www.api.org/apiqr](http://www.api.org/apiqr)

## API Training Provider Certification Program (API TPCP®)

Sales: 877-562-5187  
(Toll-free U.S. and Canada)  
(+1) 202-682-8041  
(Local and International)  
Email: [tpcp@api.org](mailto:tpcp@api.org)  
Web: [www.api.org/tpcp](http://www.api.org/tpcp)

## API Individual Certification Programs (ICP™)

Sales: 877-562-5187  
(Toll-free U.S. and Canada)  
(+1) 202-682-8041  
(Local and International)  
Email: [icp@api.org](mailto:icp@api.org)  
Web: [www.api.org/icp](http://www.api.org/icp)

## API Engine Oil Licensing and Certification System (EOLCS™)

Sales: 877-562-5187  
(Toll-free U.S. and Canada)  
(+1) 202-682-8041  
(Local and International)  
Email: [eolcs@api.org](mailto:eolcs@api.org)  
Web: [www.api.org/eolcs](http://www.api.org/eolcs)

## Motor Oil Matters™

Sales: 877-562-5187  
(Toll-free U.S. and Canada)  
(+1) 202-682-8041  
(Local and International)  
Email: [motoroilmatters@api.org](mailto:motoroilmatters@api.org)  
Web: [www.motoroilmatters.org](http://www.motoroilmatters.org)

## API Diesel Exhaust Fluid™ Certification Program

Sales: 877-562-5187  
(Toll-free U.S. and Canada)  
(+1) 202-682-8041  
(Local and International)  
Email: [apidef@api.org](mailto:apidef@api.org)  
Web: [www.apidef.org](http://www.apidef.org)

## API Perforator Design™ Registration Program

Sales: 877-562-5187  
(Toll-free U.S. and Canada)  
(+1) 202-682-8041  
(Local and International)  
Email: [perfdesign@api.org](mailto:perfdesign@api.org)  
Web: [www.api.org/perforators](http://www.api.org/perforators)

## API WorkSafe™

Sales: 877-562-5187  
(Toll-free U.S. and Canada)  
(+1) 202-682-8041  
(Local and International)  
Email: [apiworksafe@api.org](mailto:apiworksafe@api.org)  
Web: [www.api.org/worksafe](http://www.api.org/worksafe)

## API-U®

Sales: 877-562-5187  
(Toll-free U.S. and Canada)  
(+1) 202-682-8041  
(Local and International)  
Email: [training@api.org](mailto:training@api.org)  
Web: [www.api-u.org](http://www.api-u.org)

## API eMaintenance™

Sales: 877-562-5187  
(Toll-free U.S. and Canada)  
(+1) 202-682-8041  
(Local and International)  
Email: [apiemaint@api.org](mailto:apiemaint@api.org)  
Web: [www.apiemaintenance.com](http://www.apiemaintenance.com)

## API Standards

Sales: 877-562-5187  
(Toll-free U.S. and Canada)  
(+1) 202-682-8041  
(Local and International)  
Email: [standards@api.org](mailto:standards@api.org)  
Web: [www.api.org/standards](http://www.api.org/standards)

## API Data™

Sales: 877-562-5187  
(Toll-free U.S. and Canada)  
(+1) 202-682-8041  
(Local and International)  
Service: (+1) 202-682-8042  
Email: [data@api.org](mailto:data@api.org)  
Web: [www.api.org/data](http://www.api.org/data)

## API Publications

Phone: 1-800-854-7179  
(Toll-free U.S. and Canada)  
(+1) 303-397-7956  
(Local and International)  
Fax: (+1) 303-397-2740  
Web: [www.api.org/pubs](http://www.api.org/pubs)  
[global.ihs.com](http://global.ihs.com)



AMERICAN PETROLEUM INSTITUTE

1220 L Street, NW  
Washington, DC 20005-4070  
USA

202-682-8000

**Additional copies are available online at [www.api.org/pubs](http://www.api.org/pubs)**

Phone Orders: 1-800-854-7179 (Toll-free in the U.S. and Canada)  
303-397-7956 (Local and International)  
Fax Orders: 303-397-2740

Information about API publications, programs and services is available  
on the web at [www.api.org](http://www.api.org).

**Product No. C66107**